

## 2.1 Understanding Building Envelope

November 2024

# WHAT WILL YOU LEARN?

Challenges in Building Design

Basics of Building Physics

Thermal Properties of Building Materials

Thermal Properties of Fenestration

Key Takeaways



# Building Design

## Challenges



# BUILDING DESIGN

Challenges: HOT versus COLD climates



**Hot Climates**

- External surfaces (roof and walls) absorb heat from solar radiation
- Heat transfer through thermal conduction to inner surfaces
- Increased discomfort from internal heat sources and reliance on fans and air conditioning systems



**Cold Climates**

- Heat loss through roofs, walls and windows
- Ventilation requirements and infiltration losses lead to excessive heating needs
- Higher energy costs and reduced thermal comfort

# BUILDING CONDITIONS

## Commercial versus residential



### COMMERCIAL BUILDINGS

- Mostly air-conditioned
- Narrow band of expected comfort
- Mostly daytime occupancy
- Air-conditioning used for longer duration and may be used throughout the year
- Heat loads in the building may have equal or more contribution from internal loads, i.e., from occupants and equipment



### RESIDENTIAL BUILDINGS

- May or may not be air-conditioned
- Broader band of expected comfort
- Mostly nighttime occupancy
- Air-conditioning used intermittently during the day and mainly in summer
- Heat loads in the building dominated by external loads i.e., those from the building envelope

# Building Physics

Building Envelope and Heat Transfer



# BUILDING ENVELOPE

## Components

Separates exterior from interior environments

Components:

- External walls
- Roof
- Windows
- Doors
- Foundation
- Floor

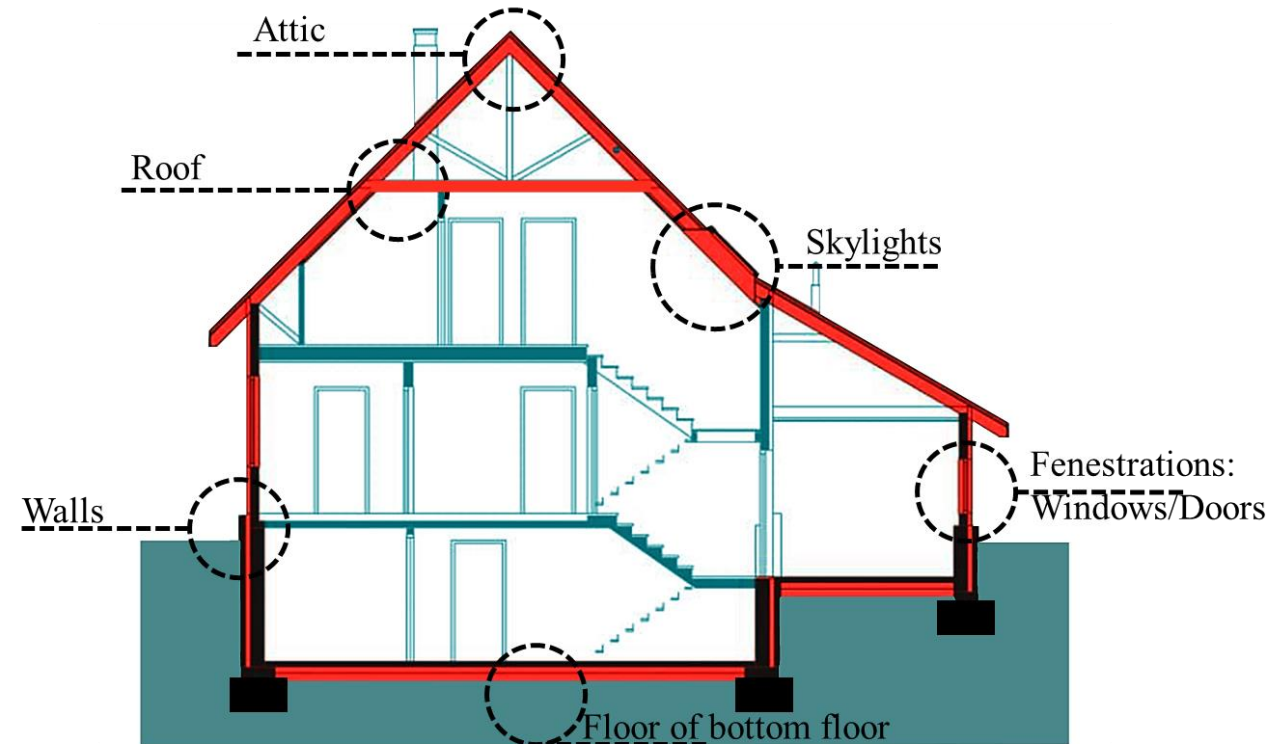

Components of a building envelope

Source: Building Energy Efficiency in Nepal (BEEN) Project, 2024

# BUILDING ENVELOPE

## Role and importance

- Physical protection
- Protection from rain and noise
- Light control
- Indoor climate regulation

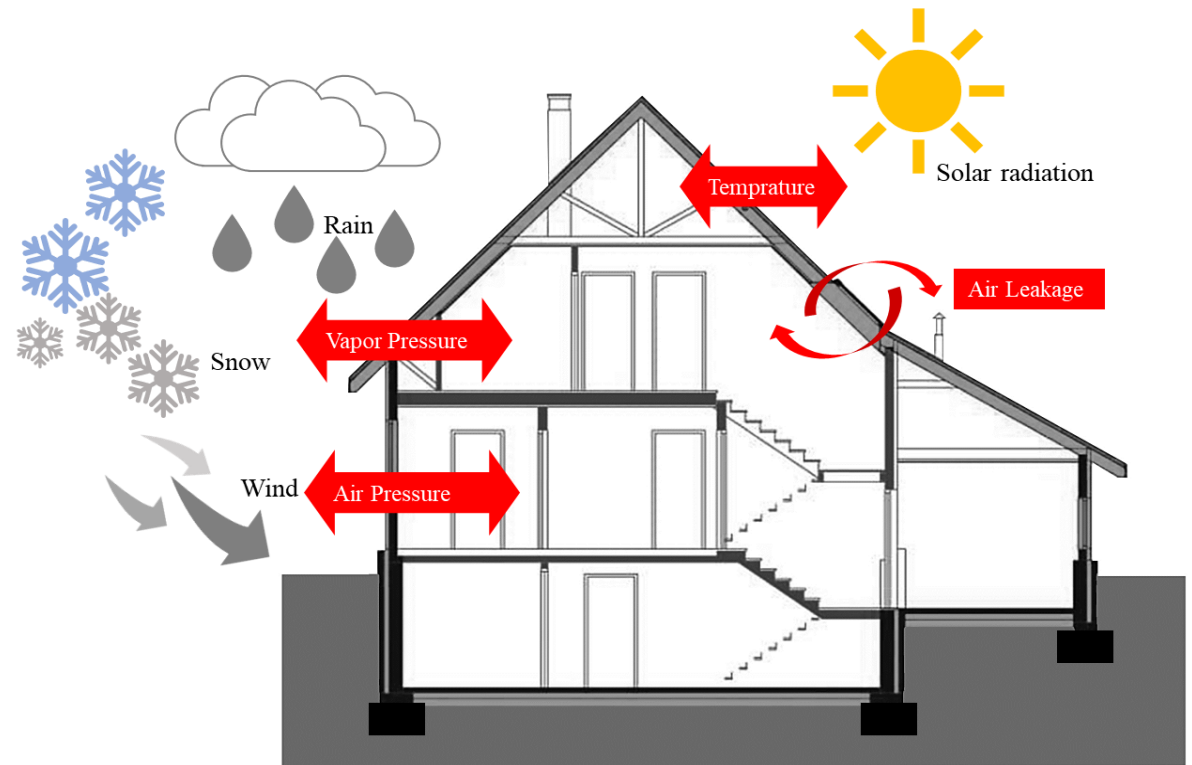

Protection from external elements through building envelope

Source: Building Energy Efficiency in Nepal (BEEN) Project, 2024

# HEAT EXCHANGE IN BUILDINGS

## Role of building envelope

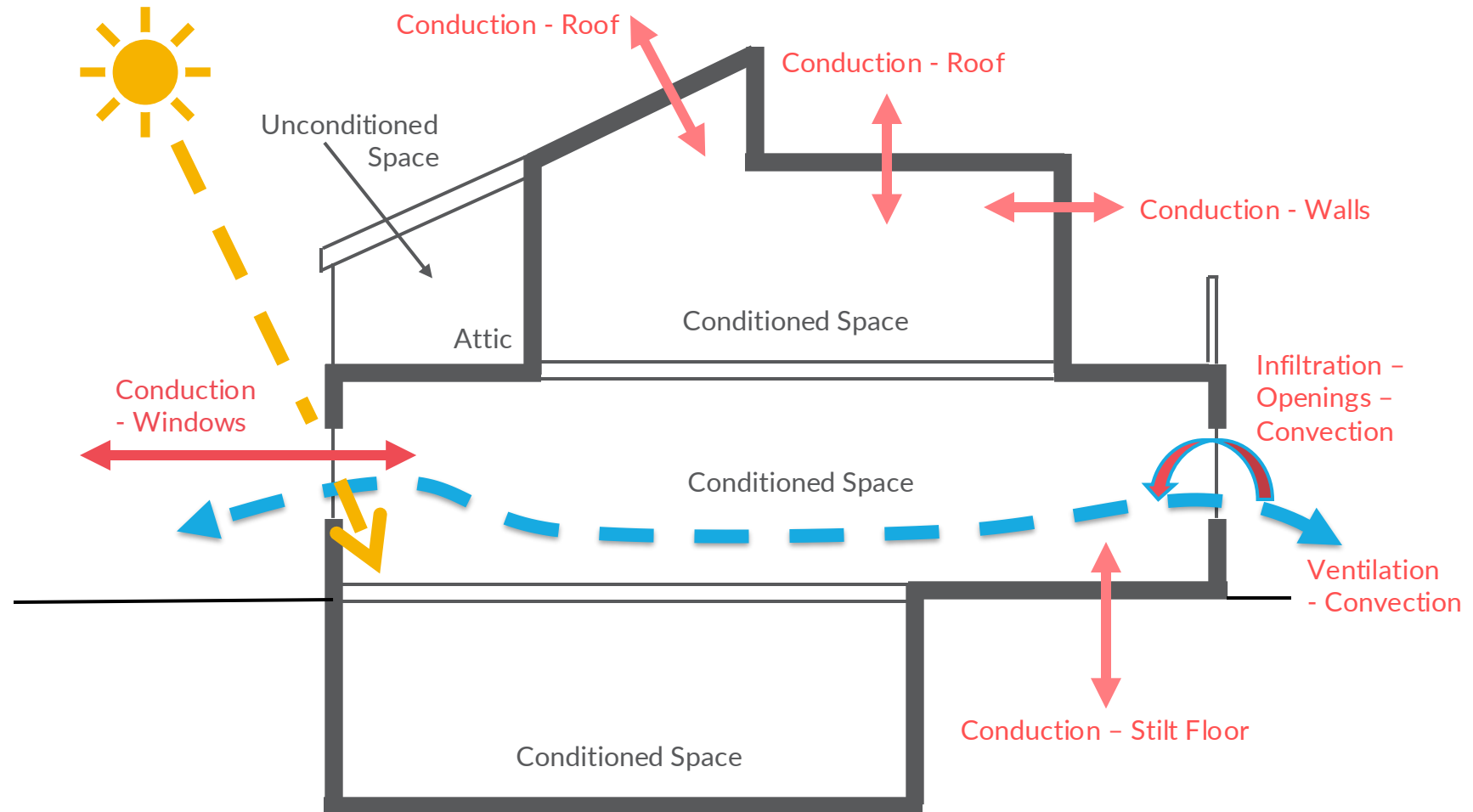

# HOW HEAT TRAVELS?

Modes of heat transfer

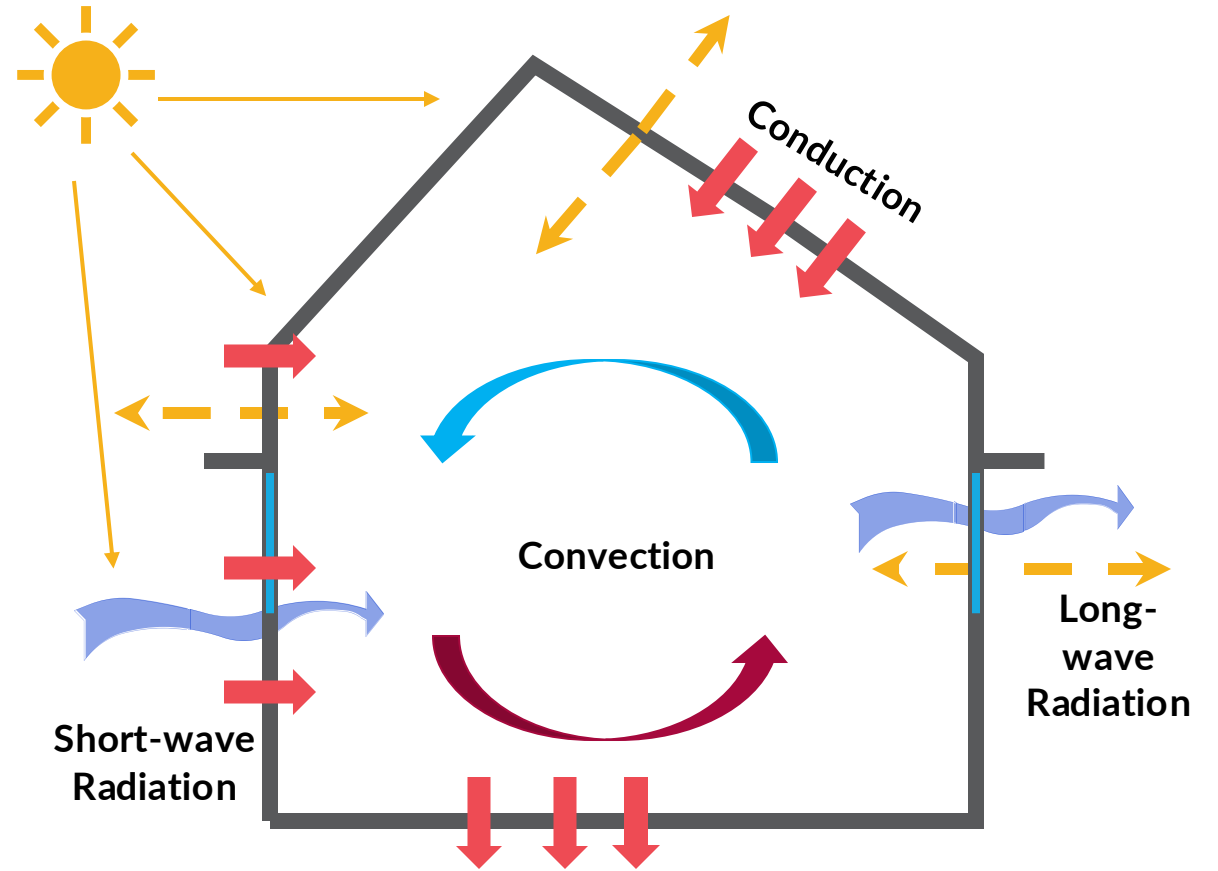
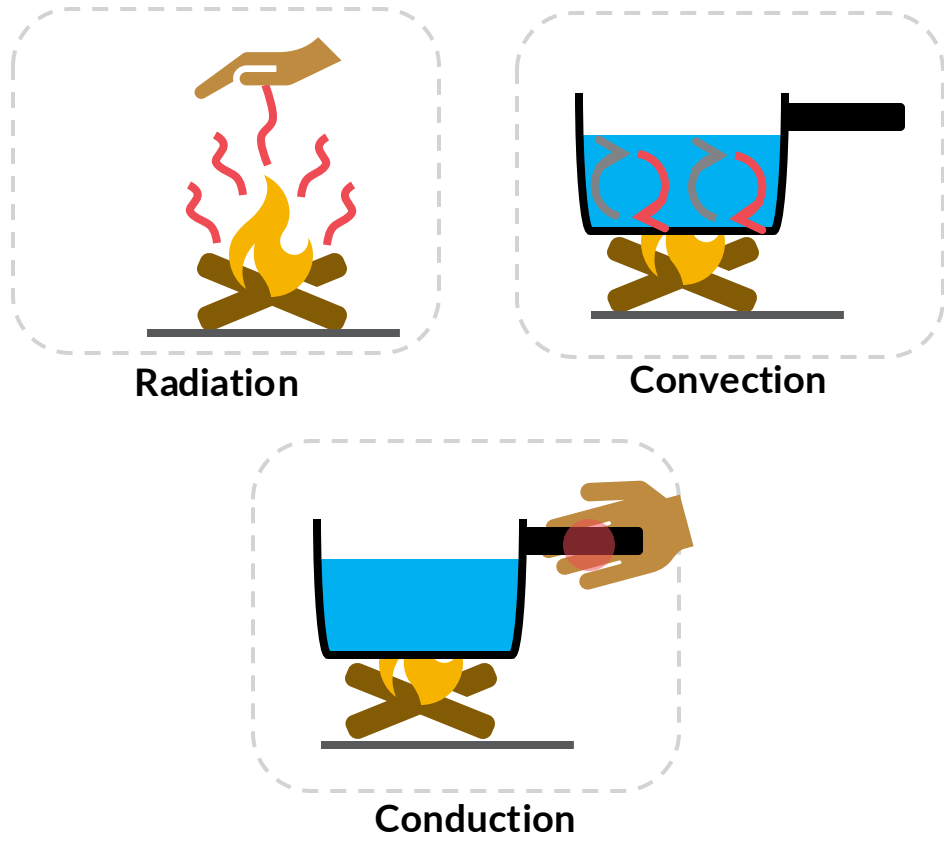

Source: Building Energy Efficiency in Nepal (BEEN) Project, 2024

# HEAT TRANSFER

Always from higher temperature to lower temperature

- Heat flows from a hot body to a cold body
- Heat is thermal energy
- Heat is transferred between bodies at different temperatures
- The measurement unit of heat is joule (J); kilowatt-hour (kWh) is also commonly used
- 1 joule corresponds to  $0.278 \times 10^{-6}$  kWh
- 1 kWh corresponds to 3.6 MJ (mega joules)

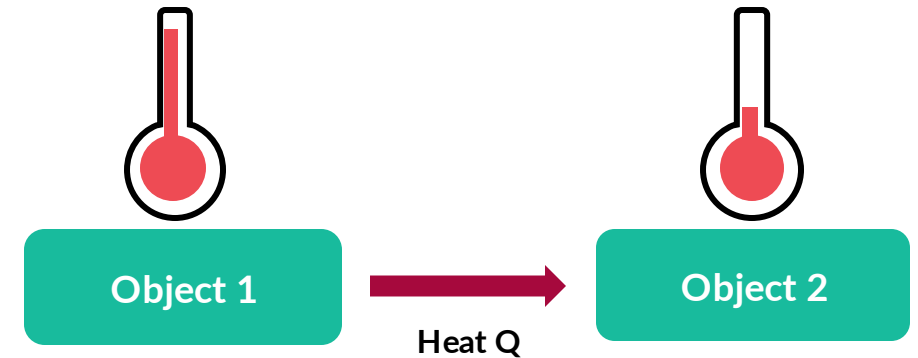

# CONDUCTION

Heat diffusion through solids: Hot to cold

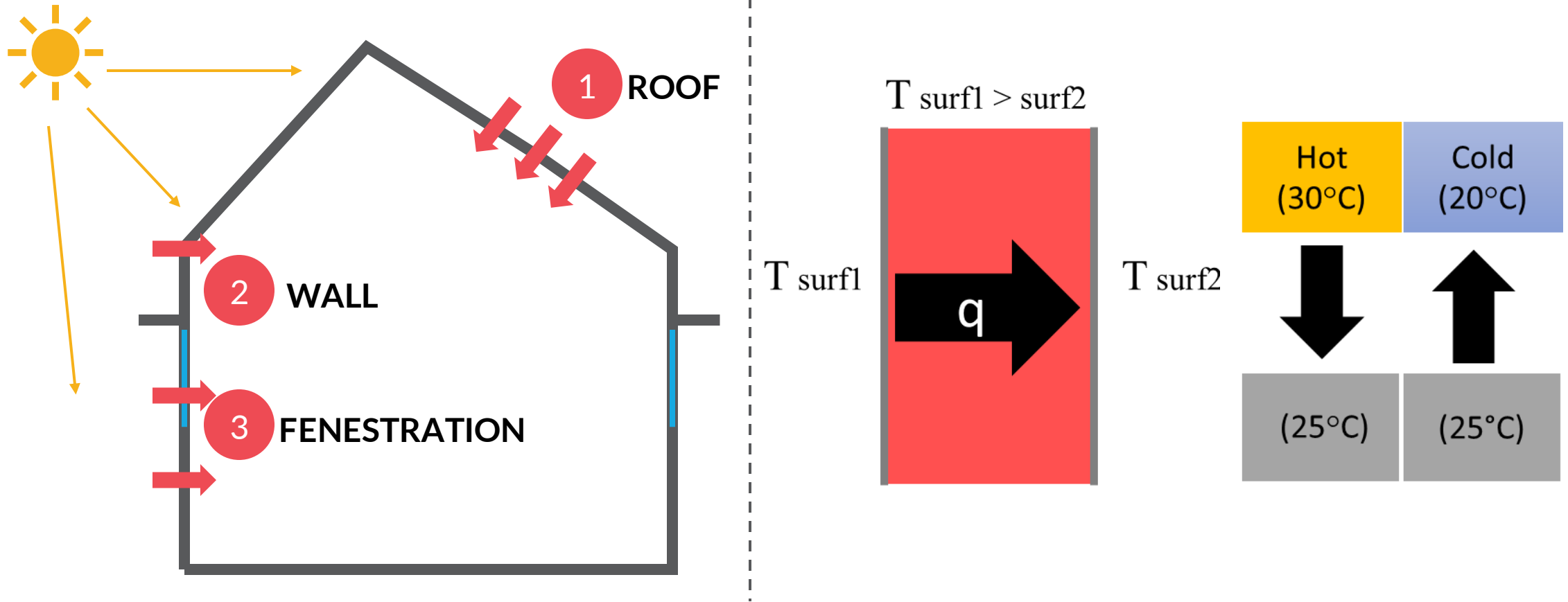

Source: Building Energy Efficiency in Nepal (BEEN) Project, 2024

# CONVECTION

Heat transfer by fluid movement

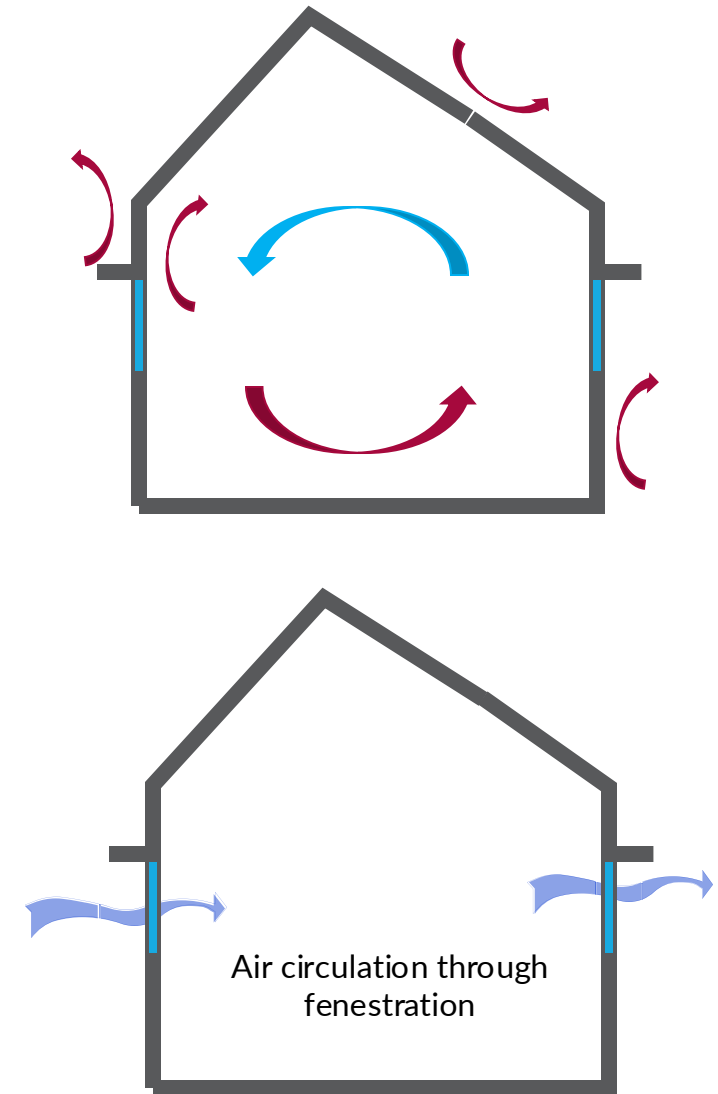
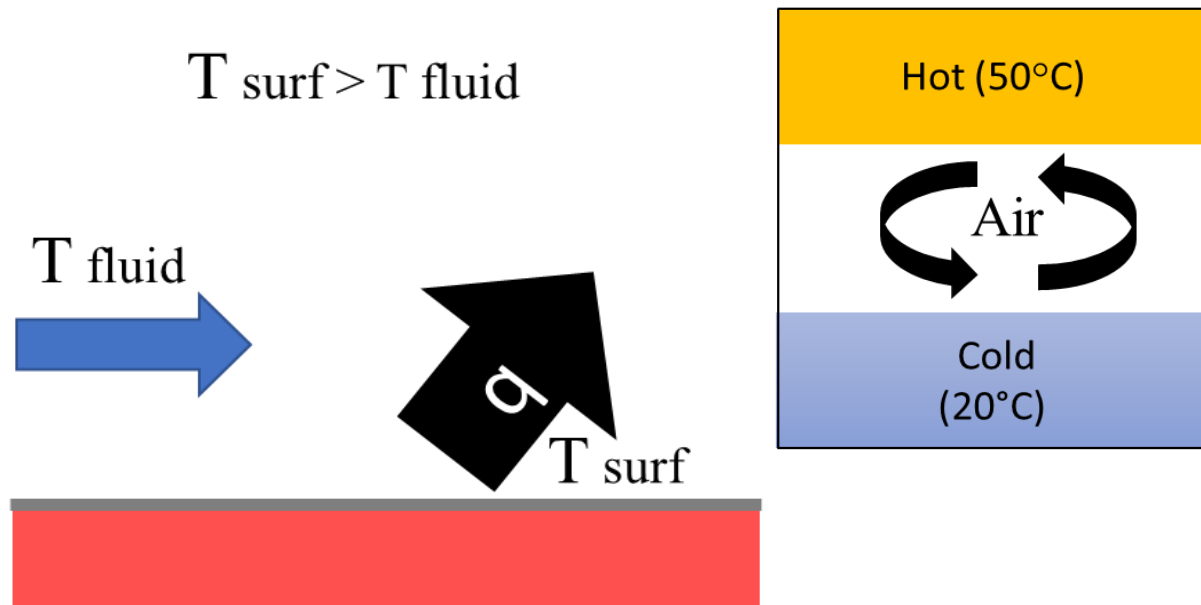

Source: Building Energy Efficiency in Nepal (BEEN) Project, 2024

# RADIATION

Heat transfer via electromagnetic waves

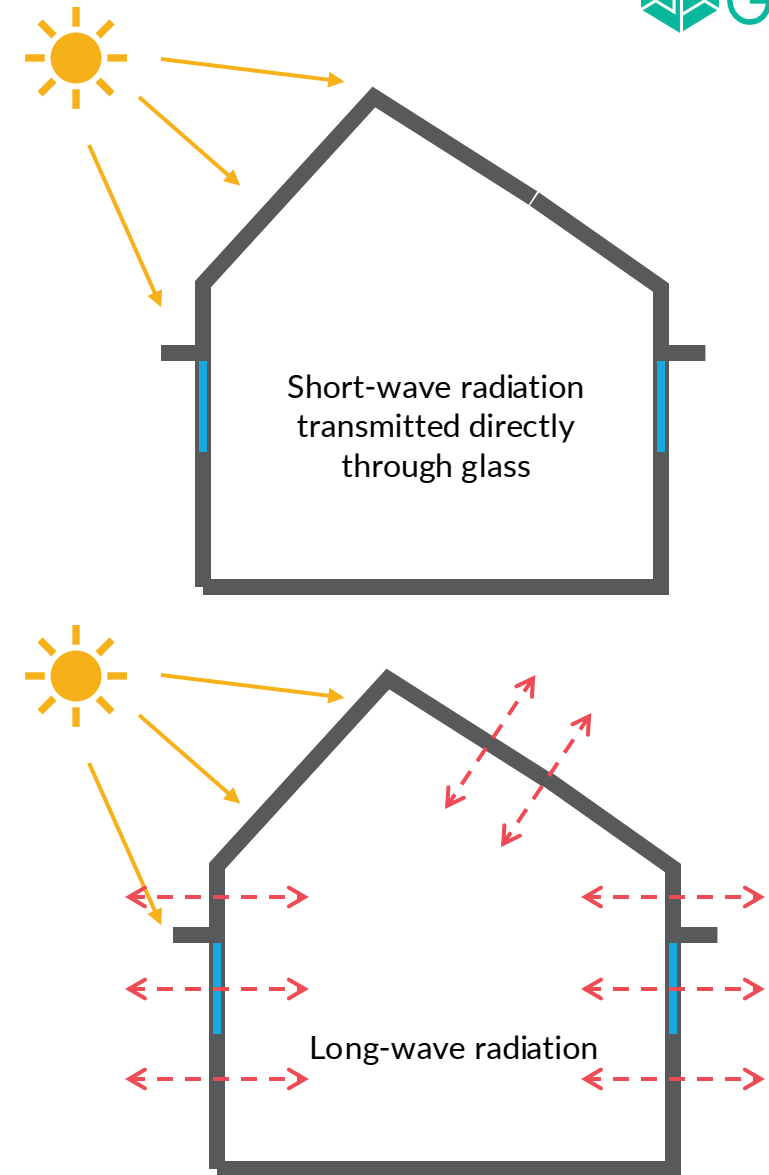
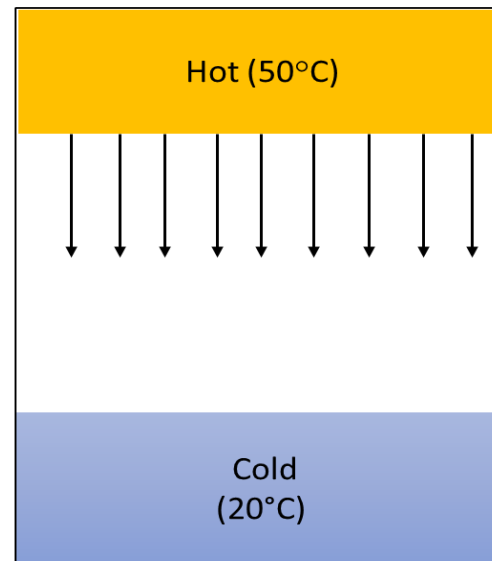
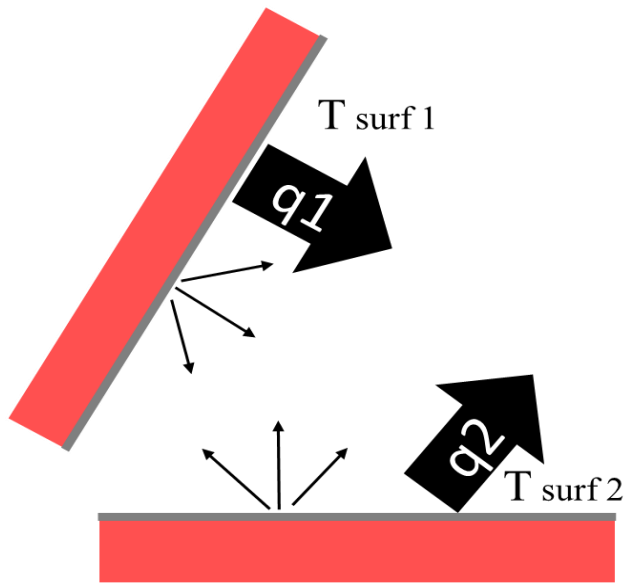

Source: Building Energy Efficiency in Nepal (BEEN) Project, 2024

# Building Materials

## Thermal Properties



Image source: <https://www.bricknbolt.com/blogs-and-articles/construction-guide/building-material-density-importance-construction>

# THERMAL CONDUCTION

## Understanding parameters

Thermal Conduction (K-value)

Low K-value = **good insulation**

Thermal Resistance (R-value)

High R-value = **good resistance**

Thermal Transmittance (U-value)

Low U-value = **low heat transfer**

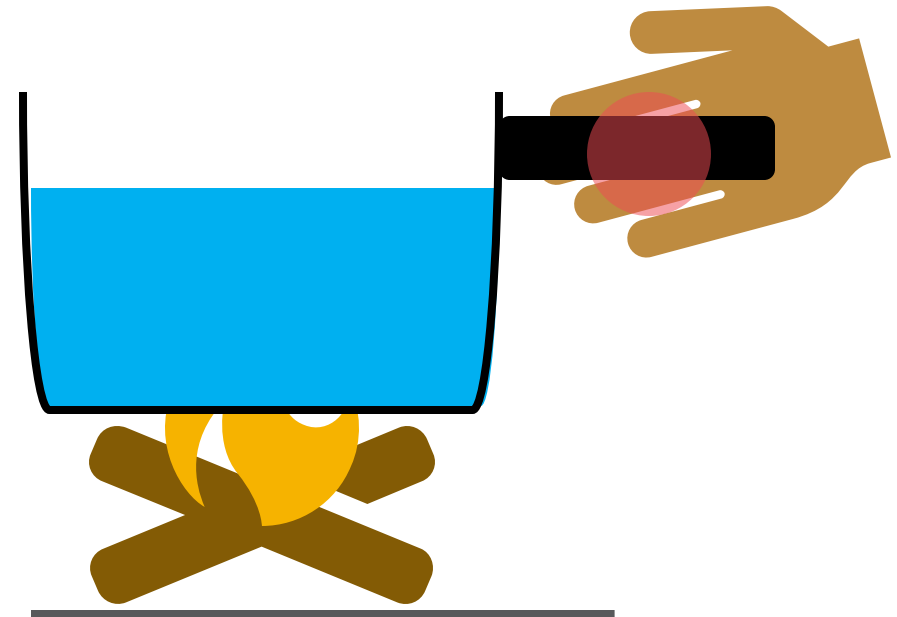

# THERMAL PROPERTIES

## Walls and roofs

- Reflectance and emissivity, combined as Solar Reflective Index (SRI)
- Thermal conductivity and transmittance (ability to conduct heat)
- Thermal mass (ability to absorb and store heat)

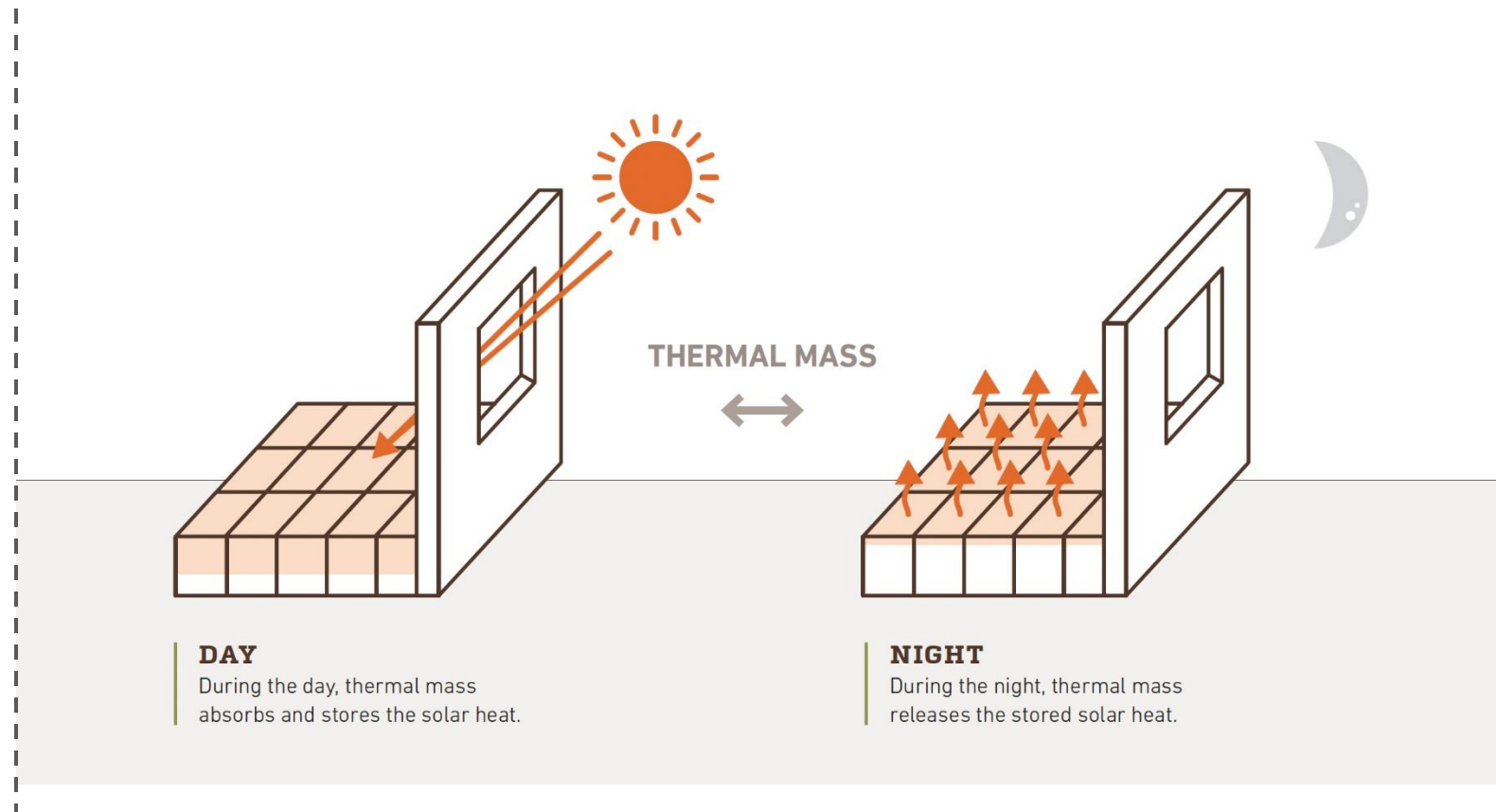
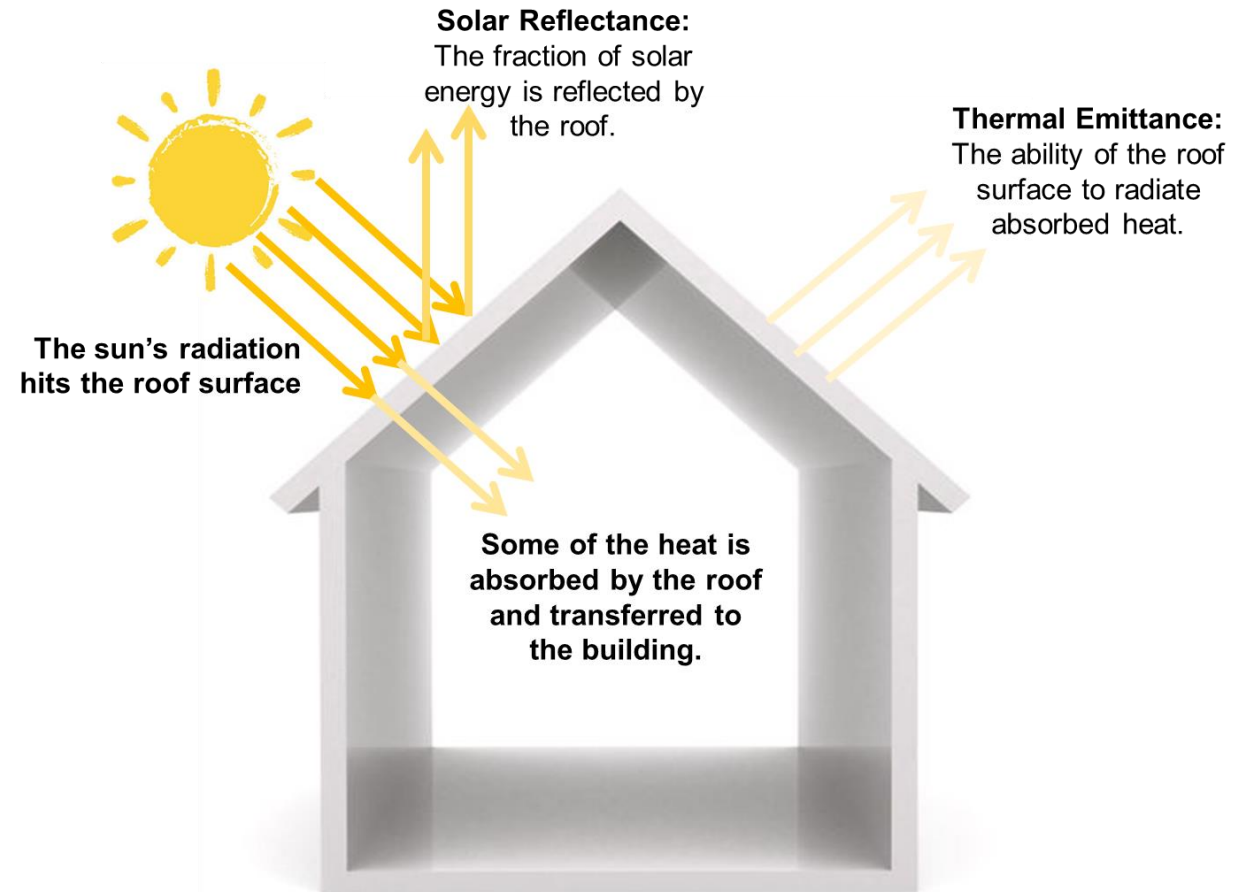

Image source: <https://www.echelonmasonry.com/2018/06/29/capitalizing-on-thermal-mass-to-improve-efficiency-in-construction/>

# SOLAR REFLECTIVE INDEX

SRI: Combination of solar reflectance and thermal emittance

- Calculated value that combines solar reflectance and thermal emittance into one number
- SRI can be used as an indicator of how hot the material is likely to become when solar radiation is incident on the surface
- SRI values for most materials fall between 0 and 100, although values outside of this range is possible
- High SRI roof and wall finishes are beneficial in warm and hot climates



Source: Building Energy Efficiency in Nepal (BEEN) Project, 2024

# THERMAL CONDUCTIVITY

## K-value

Measured in watts per meter-degree kelvin (W/m.K)

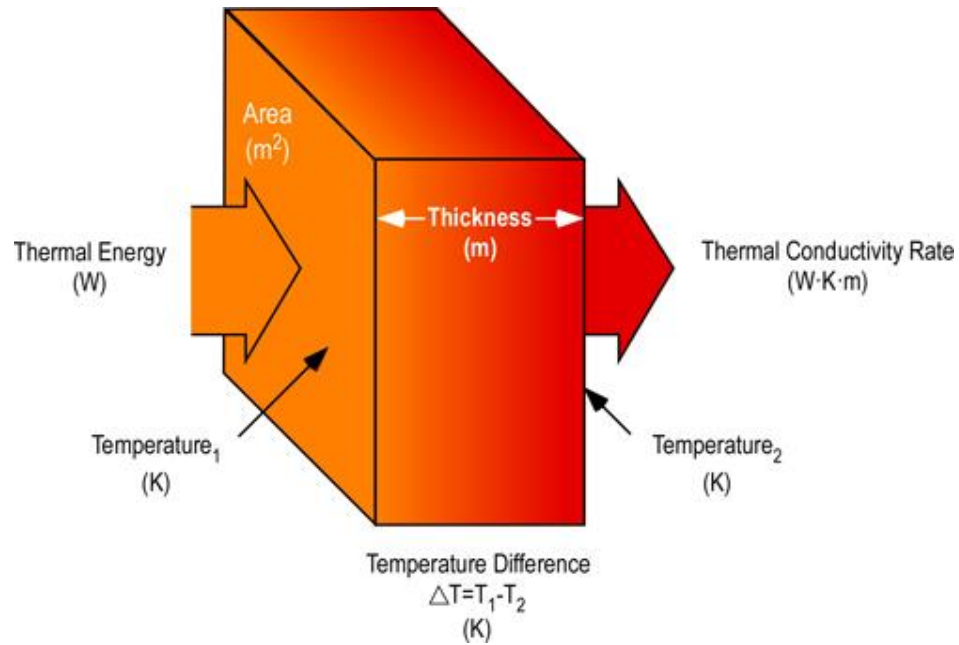

Heat transferred in unit time, through unit area ( $1m^2$ ) of homogenous material, of unit thickness (1m) of the material, with the two surfaces of the material differing by one unit of temperature ( $1^\circ K$ )

Thermal conductivity of common building materials

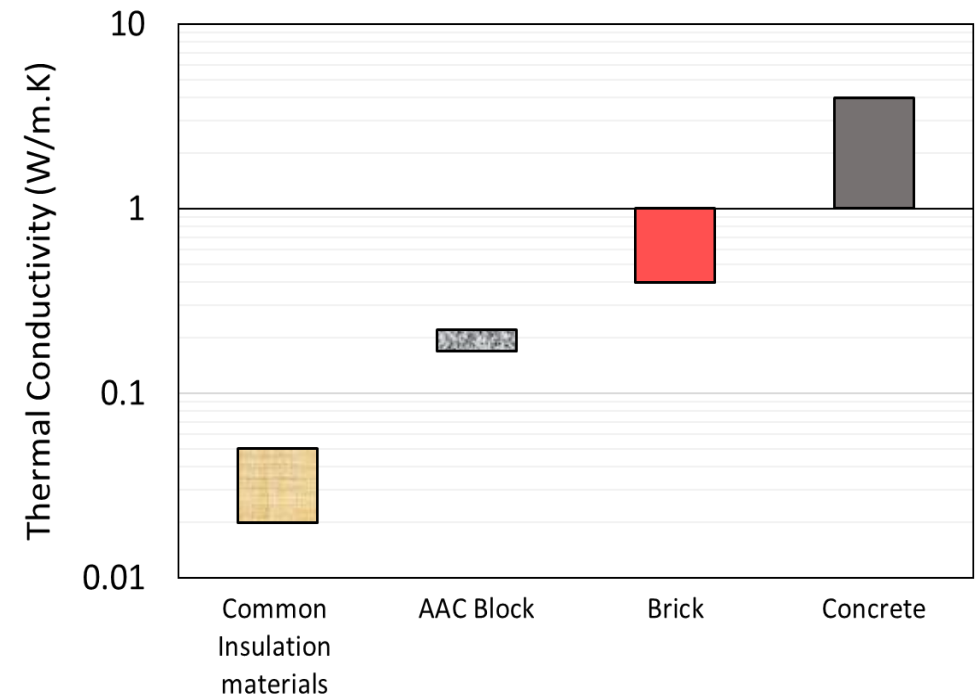

Source: Building Energy Efficiency in Nepal (BEEN) Project, 2024

# THERMAL TRANSMITTANCE

## U-value

Heat transmission, in unit time through unit area of a material or construction and the boundary air films, induced by unit temperature difference between the environments on either side

The unit of U-value is  $W/m^2.K$

$$U = \frac{1}{R_{si} + R_{se} + \frac{t_1}{k_1} + \frac{t_2}{k_2} + \dots + \frac{t_n}{k_n}}$$

$R_{si}$  is the interior surface film thermal resistance,  $m^2.K/W$

$R_{se}$  is the exterior surface film thermal resistance,  $m^2.K/W$

$t$  is the thickness of material (in meters)

$k$  is the thermal conductivity of material,  $W/(m.K)$

# MATERIAL THICKNESS

For U-value of 0.40 W/m<sup>2</sup>.K



RCC  
3.7m thick

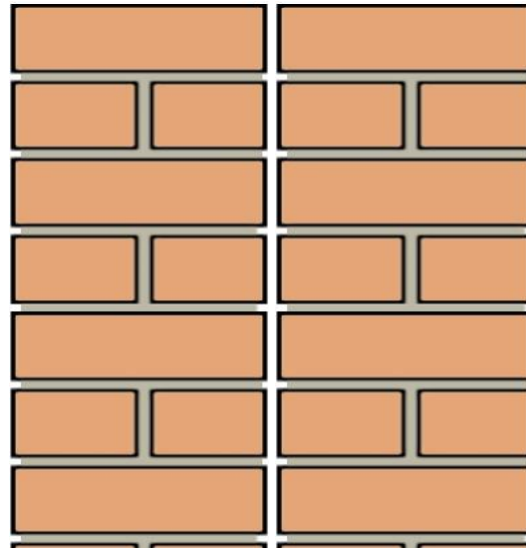

Brick  
1.8m thick



AAC  
0.42m thick



XPS  
0.08m thick

Source: Building Energy Efficiency in Nepal (BEEN) Project, 2024

# MATERIAL THICKNESS

For different wall assemblies



Hollow Brick Wall

Total thickness: 230mm  
U-value: 1.85 W/m<sup>2</sup>.K



Autoclaved Aerated  
Concrete (AAC) Wall

Total thickness: 230mm  
U-value: 0.96 W/m<sup>2</sup>.K



Cavity Wall with  
Insulation

Total thickness: 255mm  
(with 25mm mineral wool insulation)  
U-value: 0.74 W/m<sup>2</sup>.K

Source: UNEP, Compendium of Passive Cooling Strategies in Cambodia (draft)

# THERMAL MASS

## Heat capacity of a material

- Thermal mass is the property of a **building's mass** that enables it to store heat, providing 'inertia' against temperature fluctuations
- Scientifically, thermal mass is **equivalent to heat capacity** – the amount of heat to be supplied to a given mass of a material to produce a unit change in its temperature
- The unit of measurement is joule per kelvin ( $J/^\circ K$ )
- The use of materials with high thermal mass is most advantageous where there is a big difference in outdoor temperatures from day to night

Depending on the climate, building usage and comfort requirement, a higher OR lower thermal mass should be preferred

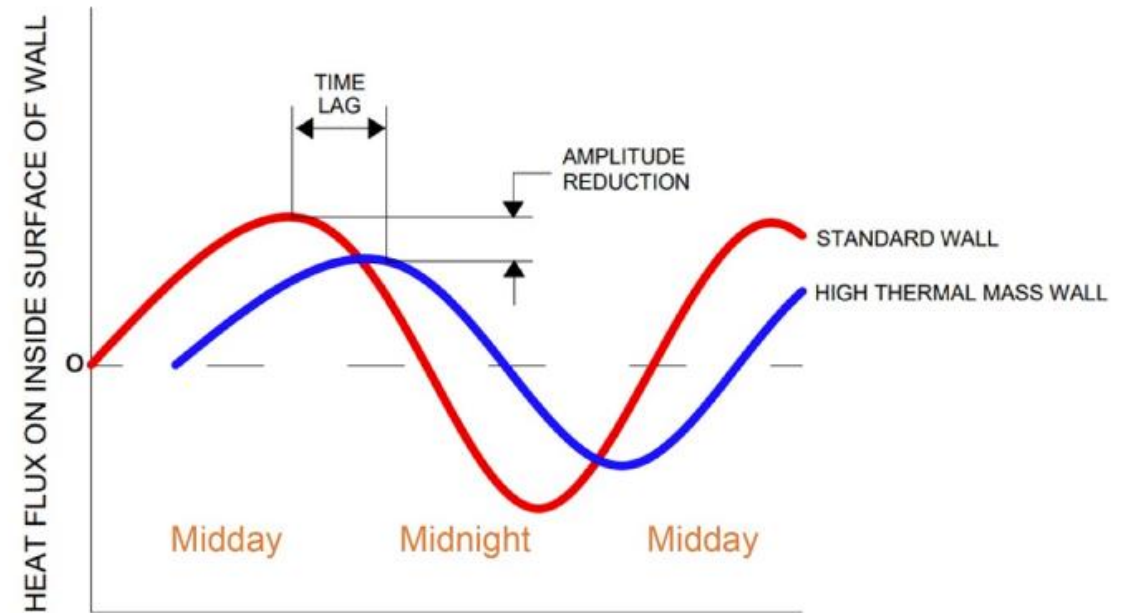

Impact of thermal mass on heat exchange

# THERMAL BRIDGES

Pathways for heat or cold transmission

## Description:

- Pathways for heat or cold to cross from inside to outside
- Reduce insulation effectiveness and can cause condensation

## Minimization techniques:

- Using external insulation
- Installing thermal breaks in metal frames
- Fixing prefab insulated panels over frames
- Using less conductive framing materials (e.g., timber, UPVC)

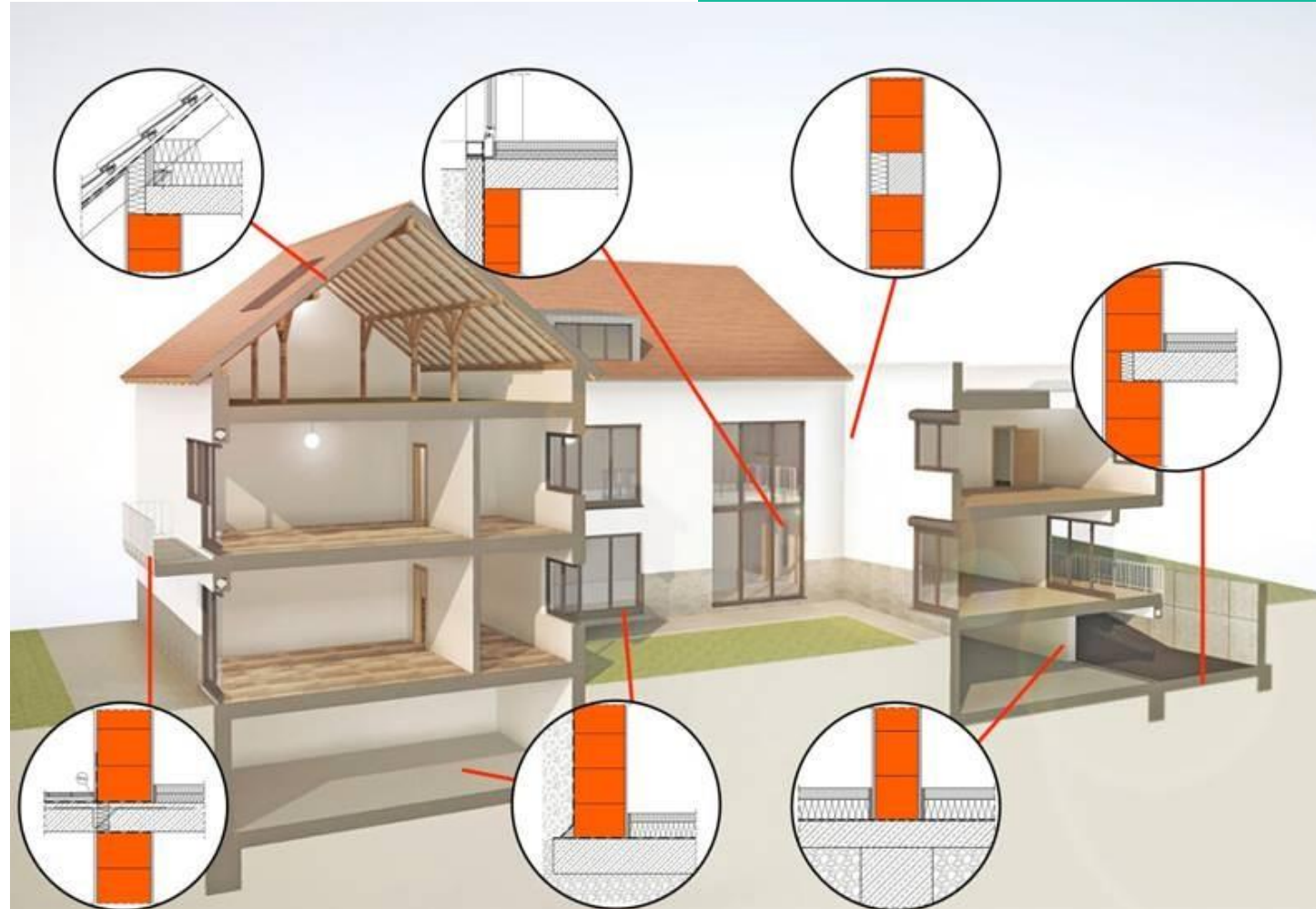

Source: Building Energy Efficiency in Nepal (BEEN) Project, 2024

# SOLAR RADIATION

## Components of solar radiation

- **Solar reflectance:** Energy reflected back to the atmosphere
- **Solar absorptance:** Energy absorbed by the roof and transferred to the building's interior
- **Solar emittance:** Absorbed solar energy radiated back to the atmosphere

Standard white surface  
(reflectance 0.80,  
emittance 0.90):  
SRI = 100

Standard black surface  
(reflectance 0.05,  
emittance 0.90):  
SRI = 0

Roofs attract solar radiation almost throughout the day and need to be protected more than the walls

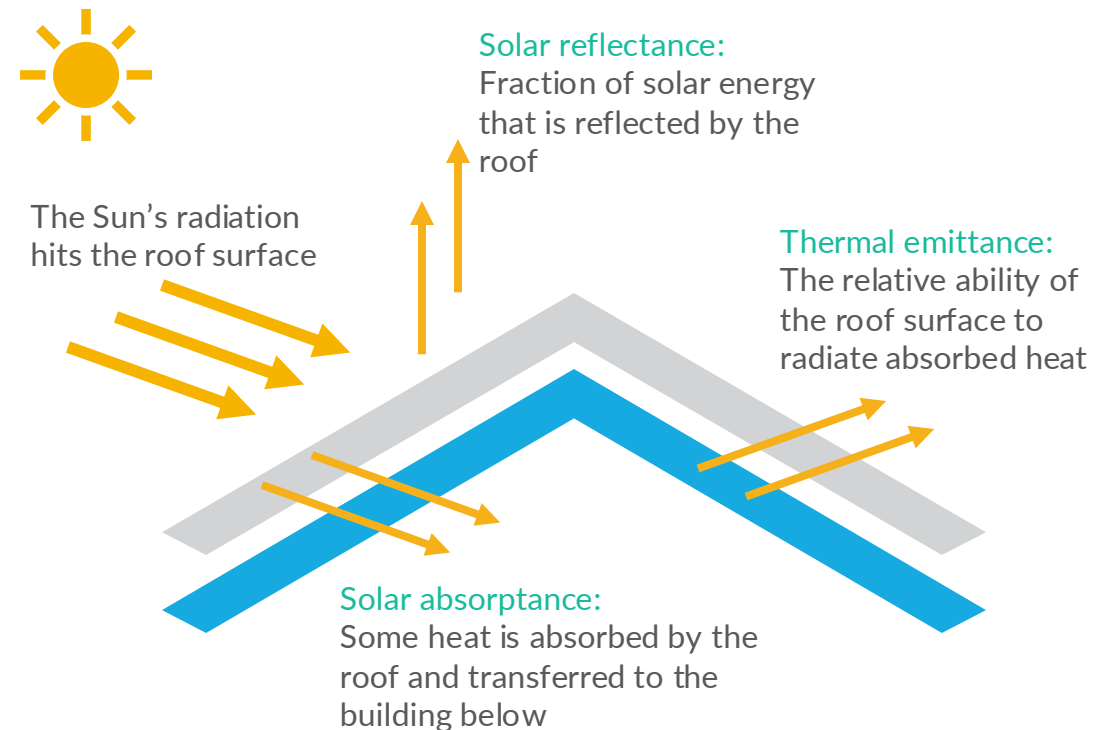

Source: ECBC User Guide, July 2009

# Fenestration

## Thermal Properties



# FENESTRATION

## Heat transfer

- In a building, fenestration comprises both opaque and solid elements (such as wood, aluminum, etc.) and non-opaque or transparent elements (i.e., glass). Between the two, a significant amount of heat transfer occurs through the glass
- In addition to conduction, heat transfer occurs through infiltration, i.e., unintentional air entering a space through the cracks and gaps in the fenestration elements. This is part of the air exchange process

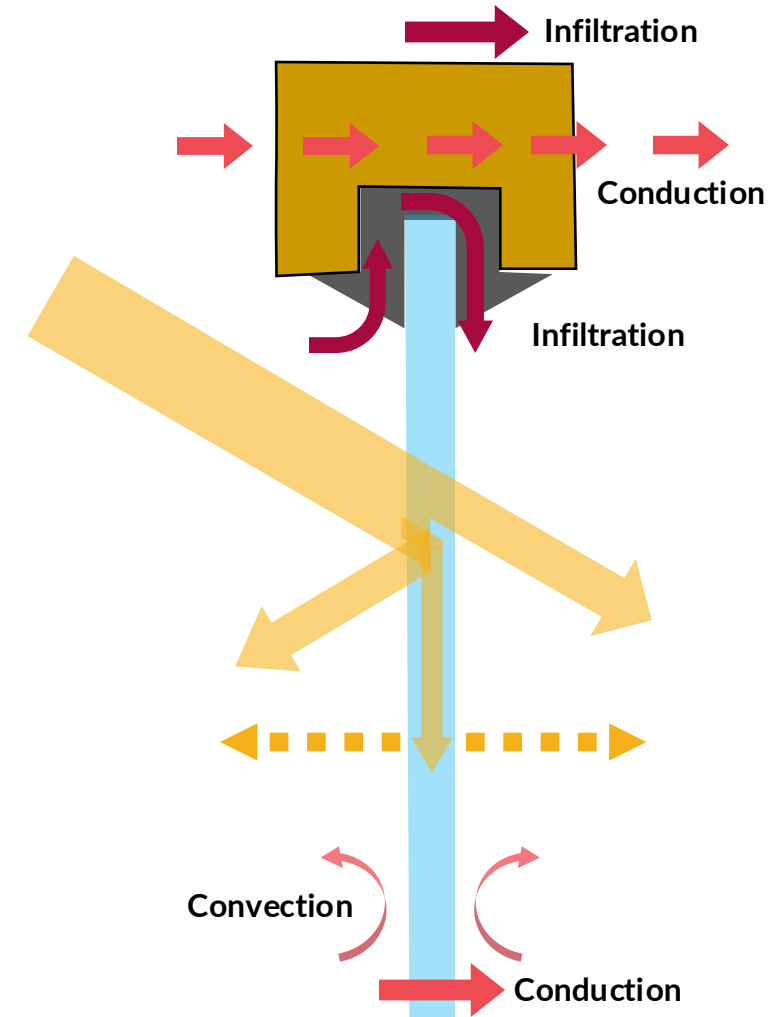

Source: Building Energy Efficiency in Nepal (BEEN) Project, 2024

# GLAZING

## Key parameters

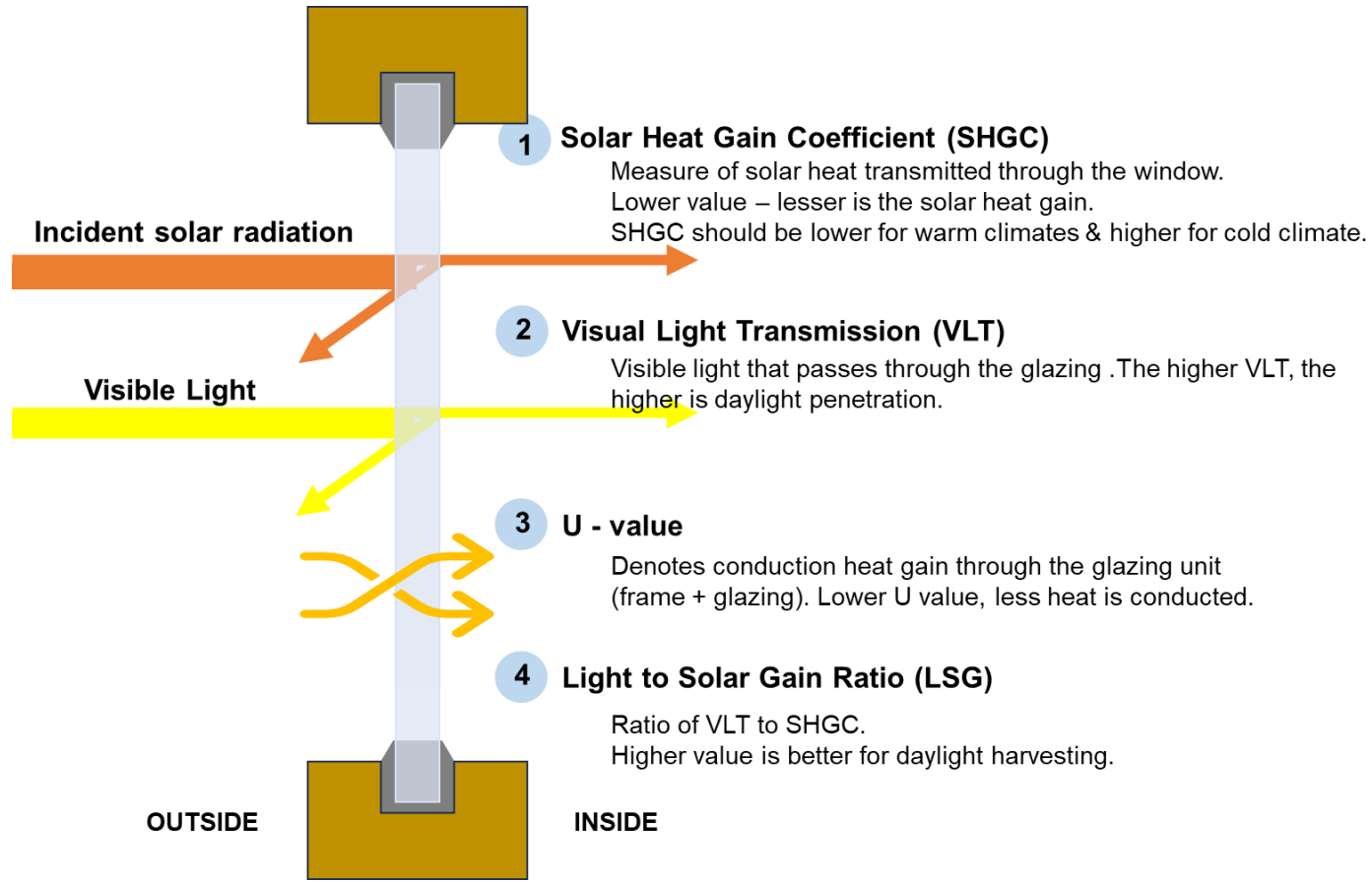

Source: Building Energy Efficiency in Nepal (BEEN) Project, 2024

# GLAZING

## U-value

- In the United States, values are normally given for NFRC / ASHRAE winter conditions of 0°F (-18°C) outdoor temperature, and for 70°F (21°C) indoor temperature, with 15 mph of wind speed, and no solar load
- U-values are often quoted for windows and doors
- In the case of a window, for example, the U-value may be expressed for the glass alone or for the entire window assembly, which includes the effect of the frame and the spacer materials

Source: USAID ECO-III Tip Sheets

## Heat Transfer – Fenestration U-value

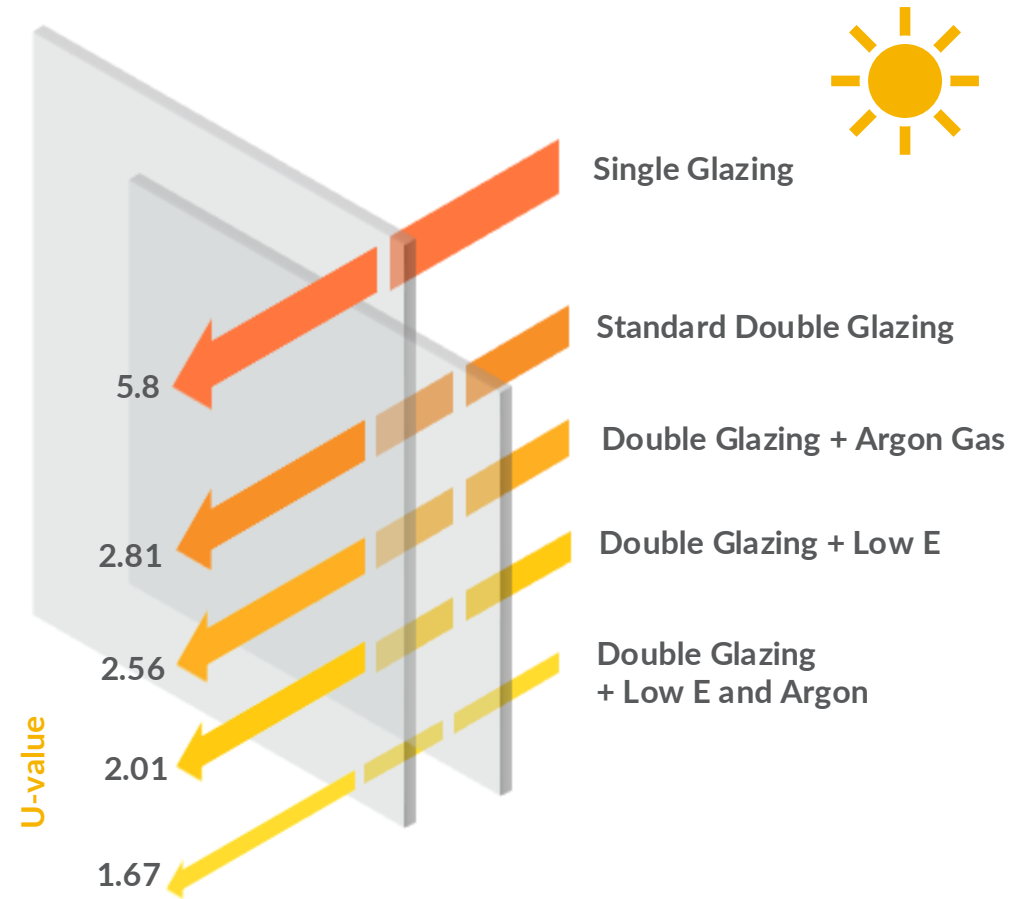

# SOLAR HEAT GAIN COEFFICIENT

## SHGC – unshaded

- SHGC is the ratio of solar heat gain that passes through fenestration to the total incident solar radiation that falls on the fenestration
- Lower SHGC means lesser heat transfers into the building through the window
- In hot climates, SHGC is more significant than U-value

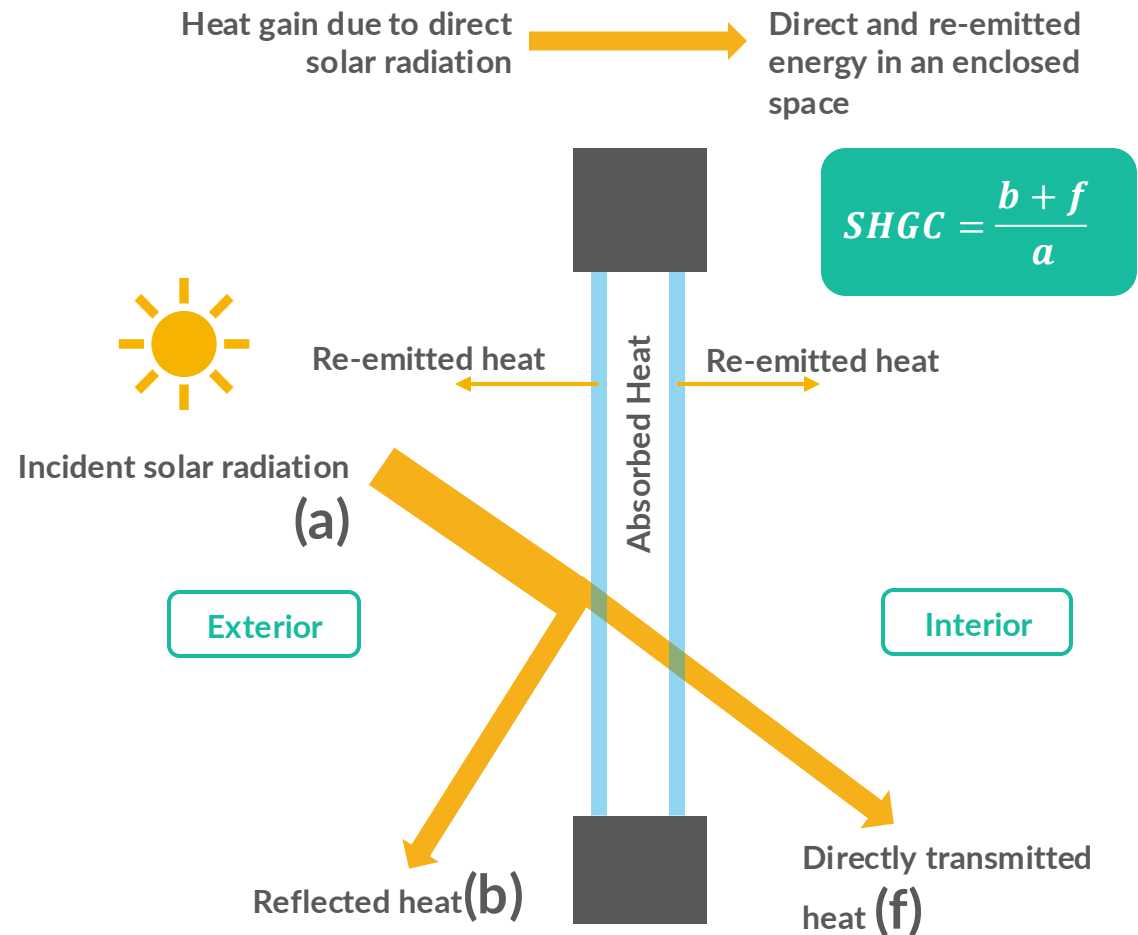

Source: USAID ECO-III Tip Sheets

# EFFECT OF SHADING

SHGC equivalent

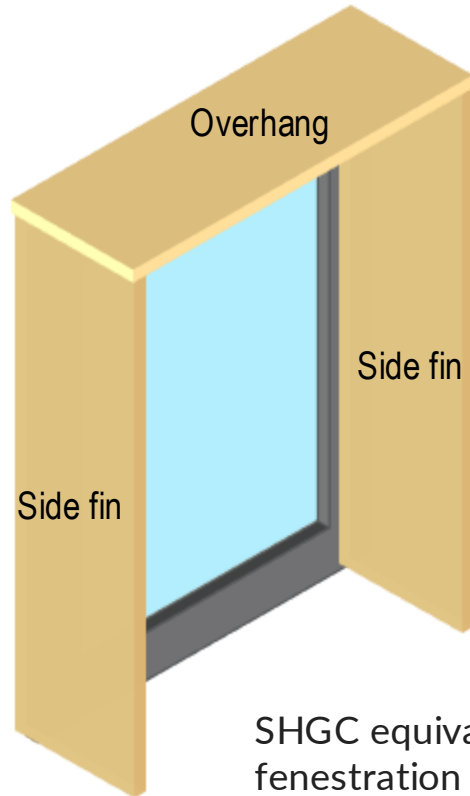

SHGC equivalent is the SHGC of a fenestration with a permanent external shading projection (overhang and side fins)

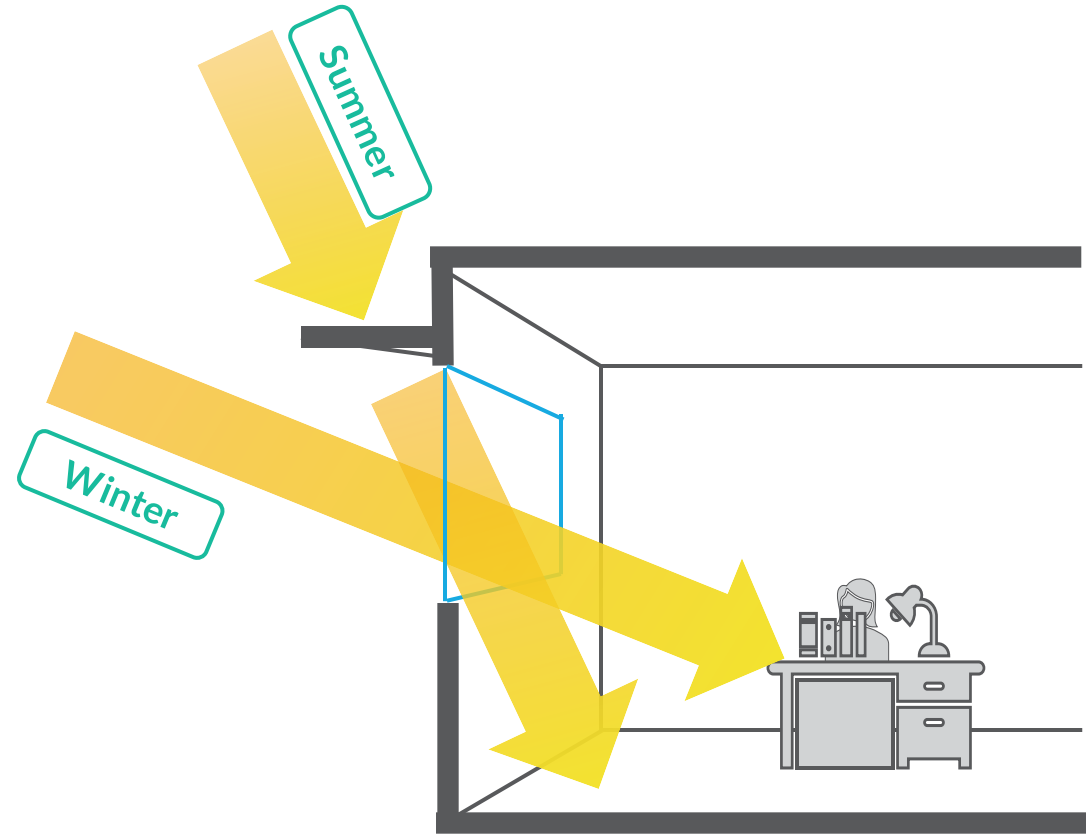

External shading devices impact the SHGC of a fenestration by impacting the solar radiation incident on the window. The impact of the shading device on the unshaded SHGC results in SHGC equivalent

Source: Building Energy Efficiency in Nepal (BEEN) Project, 2024

# EXTERNAL SHADING VS. INTERNAL SHADING

## SHGC equivalent

- Internal shading does not prevent heat from entering the building
- With internal curtains the effective SHGC is around **0.75** (with 6 mm clear glass)
- In case of external shading the heat get reflected from outside the window
- With good external shading the effective SHGC is around **0.18** (with 6 mm clear glass)

**Up to four times reduction in window solar gains with external shading as compared to internal shading**

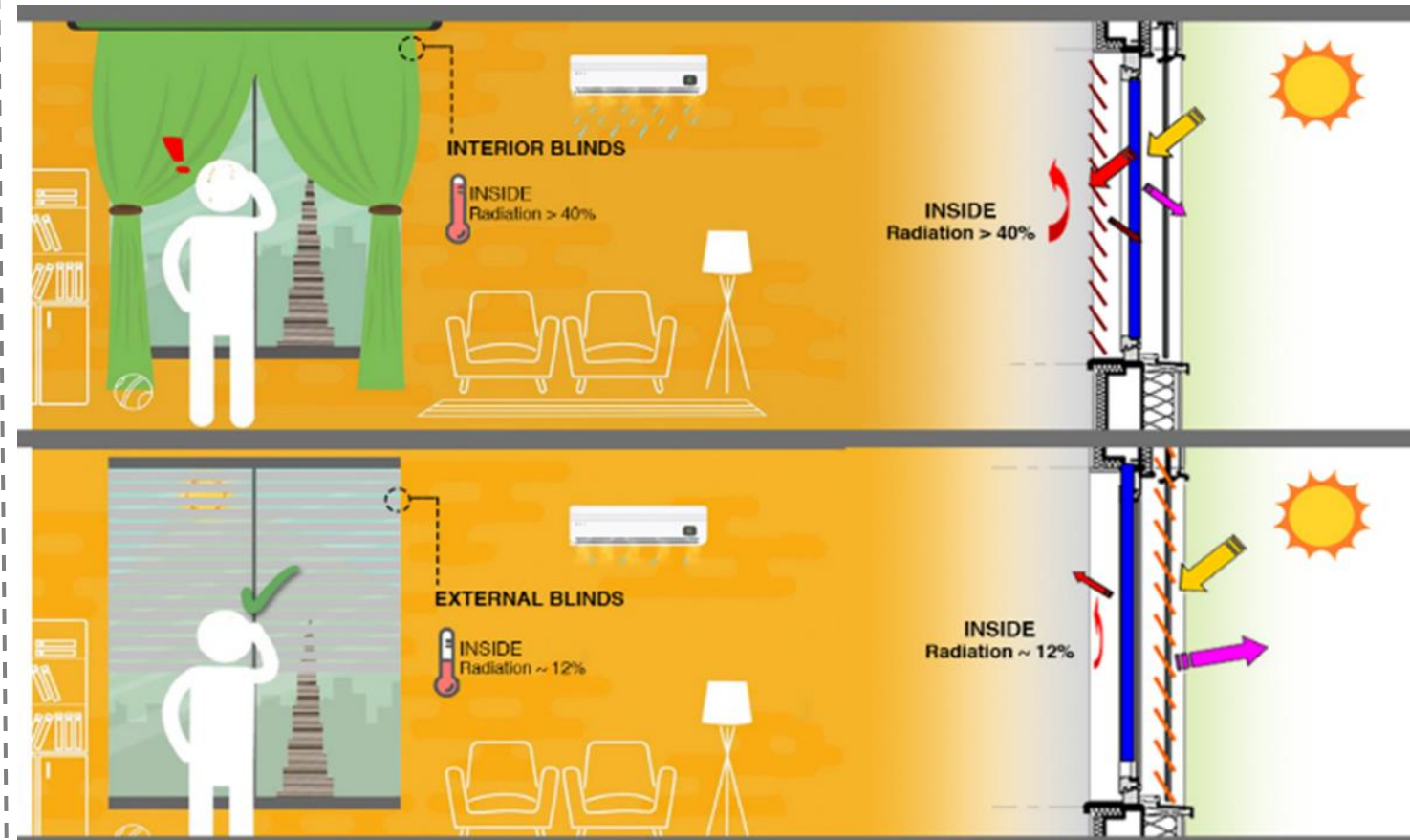

Illustration of external vs. internal shading

Source: Ministry of Power, Government of India, 2022b

# GLAZING

## Visible light transmittance (VLT)

VLT is the fraction of visible light transmitted through the glazing

- Affects daylight and visibility
- Varies between 0 and 1

Typically, the lower the SHGC, the lower the VLT

- Higher insulating property glass will reduce daylight

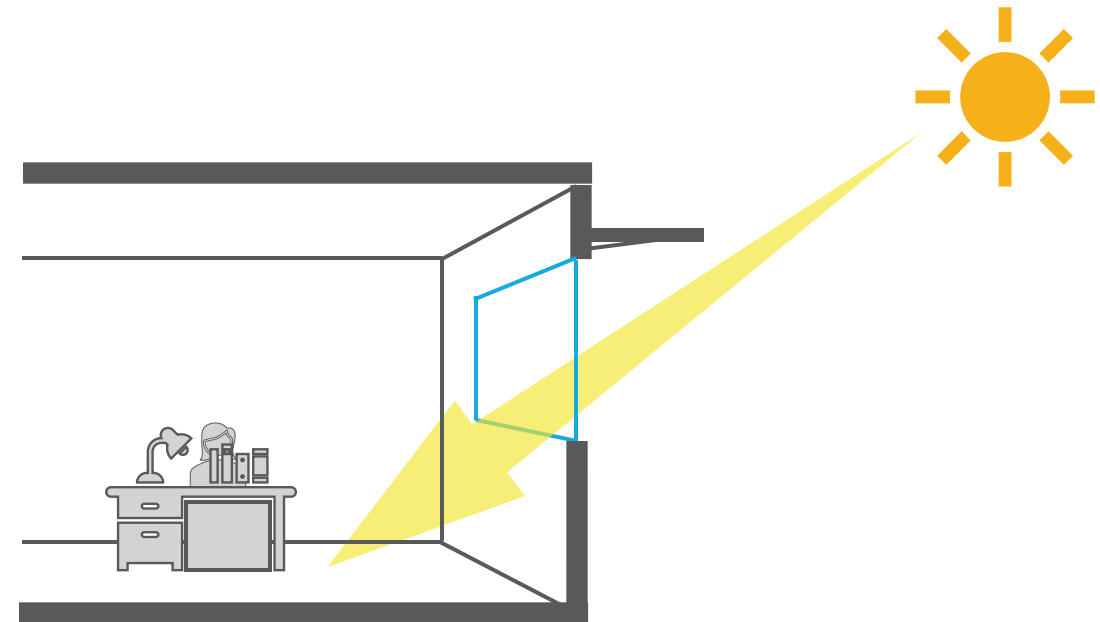

# GLAZING

## Minimum illuminance level required

- ASHRAE provides recommendations for minimum illuminance levels in different areas through its standards, particularly **ASHRAE 90.1** and **IES Lighting Handbook** (in collaboration with the Illuminating Engineering Society)
- These standards are widely referenced in building codes for energy efficiency and lighting quality
- The table shows some typical illuminance levels suggested by ASHRAE and IES for various types of spaces (measured in lux)

Area	Minimum illuminance levels
General Office Areas	300–500 lux
Conference Rooms	300–500 lux
Reception Areas	300 lux
Classrooms	300–500 lux
Laboratories	500 lux
Lecture Halls and Auditoriums	200–300 lux
Warehousing and Storage Areas	100–300 lux
Restaurants (Dining Areas)	100–300 lux

# RELATION OF SHADING COEFFICIENT AND VLT

- The graph depicts that, for clear glass, the VLT is very high, and the shading coefficient is also high, leading to heat and glare
- As selective metallic oxides are applied on clear glass (either as soft or hard coat), the glass performance improves
- Depending on the need, a balance between VLT and shading coefficient must be managed
- **For larger floor plates, VLT is not very significant, as daylight cannot penetrate more than 6–7m from perimeter**
- **For such large buildings, shading coefficient plays a major role in reducing heat gains through glazing**

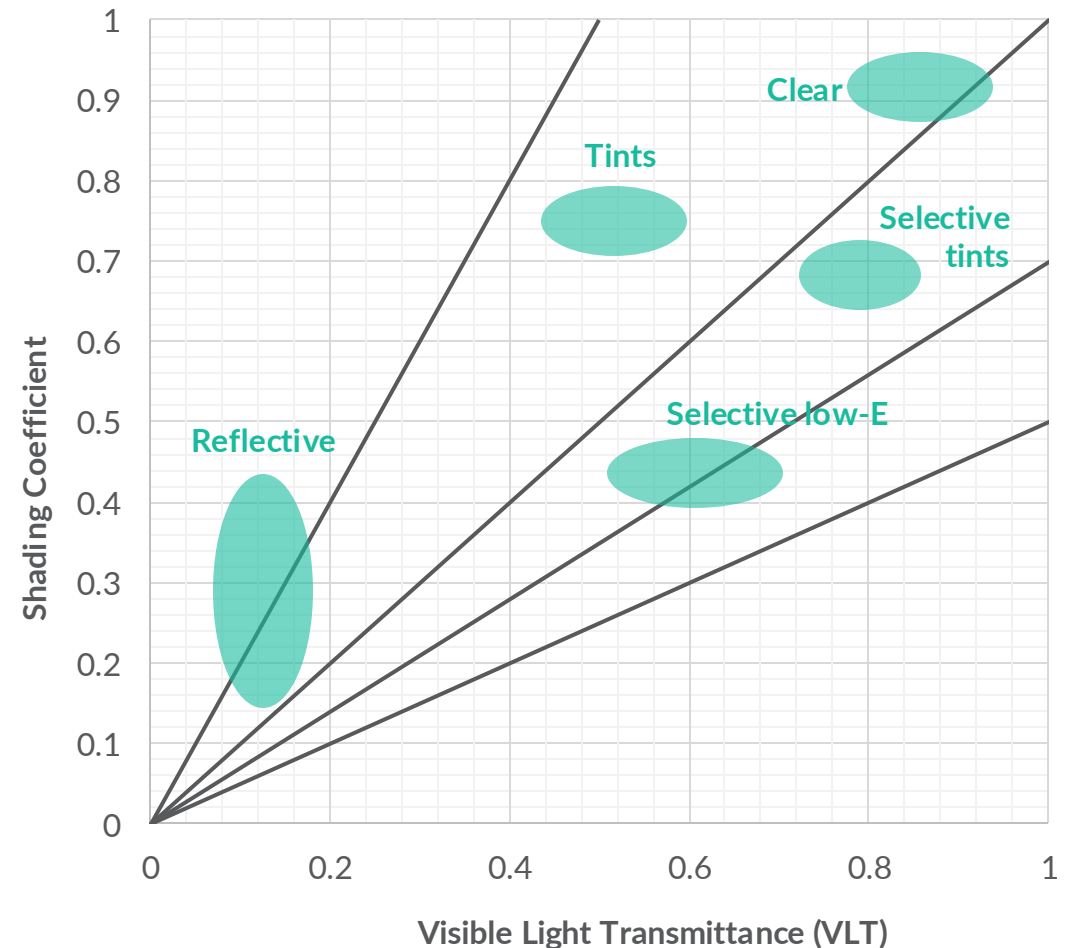

Source: USAID ECO-III Tip Sheets

# Building Heat Transfer Values

RTTV and OTTV



# ROOF THERMAL TRANSFER VALUE

## RTTV: Metric for heat transfer

- **Roof thermal transfer value (RTTV)** is a metric used to quantify heat transfer through a building's roof structure. It is commonly used in tropical and subtropical climates, where the roof is a primary source of heat gain in buildings
- RTTV is measured in **W/m<sup>2</sup>** and helps evaluate the roof's thermal performance, contributing to the building's overall energy efficiency
- **RTTV considers:**
  - **Direct solar radiation:** Heat absorbed by the roof due to sunlight
  - **Thermal conductivity:** The ability of the roof materials to conduct heat
  - **Surface temperature differentials:** The temperature difference between the inside and outside surfaces of the roof

$$RTTV = (a \times (1 - SKR) \times U_r) + (b \times SKR \times U_s) + (c \times SKR \times SC \times CF)$$

- |   |   |
|---|---|
| ▪ RTTV: roof thermal transfer value (W/m <sup>2</sup> )                       | (W/m <sup>2</sup> .K)   |
| ▪ SKR: skylight ratio of roof (skylight area/gross area of roof)              | ▪ SC: Shading coefficient of skylight   |
| ▪ U <sub>r</sub> : Thermal transmittance of opaque roof (W/m <sup>2</sup> .K) | ▪ CF: Solar correction factor for roof (based on the orientation and slope)       |
| ▪ U <sub>s</sub> : Thermal transmittance of skylight                          | ▪ a, b, c = multiplying factors determined based on the specific country/location |

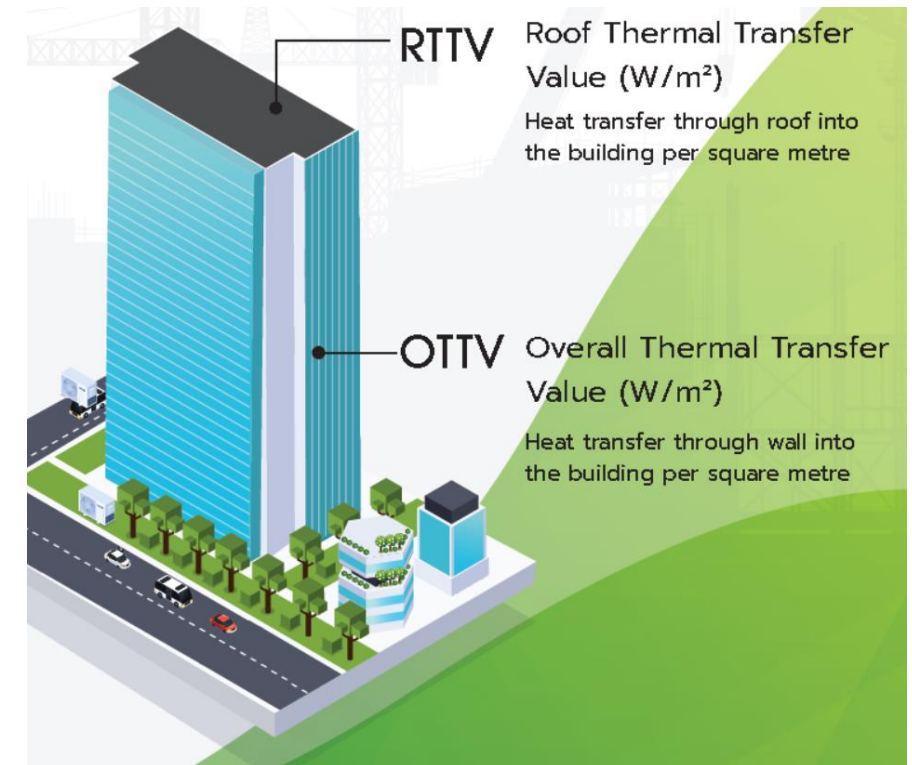

Source: Building and Construction Authority, Government of Singapore

# ROOF THERMAL TRANSFER VALUE

## RTTV: Sample calculation

For example, one building located in Singapore with the total roof (flat roof) area of 250m<sup>2</sup>, containing 50m<sup>2</sup> of skylight. The technical specification of the roof construction materials are as follows:

- $A_r=200\text{m}^2$ ,  $U_r=0.5\text{ W/m}^2\cdot\text{K}$
- $A_s=50\text{ m}^2$ ,  $U_s=3\text{ W/m}^2\cdot\text{K}$
- $SC=0.5$ ,
- $CF= 1$  (flat roof)
- $SKR= 0.2$

### Calculation of RTTV:

$$\text{RTTV}=(a\times(1- \text{SKR})\times U_r)+(b\times\text{SKR}\times U_s)+(c\times\text{SKR}\times\text{SC}\times\text{CF})$$

### Multiplier factors values for Singapore:

- $a = 12.5$
- $b = 4.8$
- $c = 485$

Breaking it down:

**Opaque roof contribution:**  $12.5\times0.8\times0.5 = 5\text{ W}$

**Skylight conduction:**  $4.8\times0.2\times3 = 2.88\text{ W}$

**Skylight solar heat gain:**  $485\times0.2\times0.5\times1 = 48.5\text{ W}$

$$\text{RTTV} = 5 + 2.88 + 48.5 = 56.38\text{ W/m}^2$$

The RTTV value of this roof is **56.4 W/m<sup>2</sup>**. This value should be below the prescribed limits mentioned in the national building energy efficiency code

Source: Building and Construction Authority, Government of Singapore

# OVERALL THERMAL TRANSFER VALUE

## OTTV: Metric for heat transfer

- **Overall thermal transfer value (OTTV)** is a widely-used metric to assess the thermal performance of the building envelope, particularly in tropical and subtropical climates. It measures the average rate of heat transfer into a building through its external walls, windows, and other opaque and transparent façades
- OTTV is expressed in **W/m<sup>2</sup>** and evaluates the thermal efficiency of external walls and fenestration systems in terms of heat gain
- **Key components of OTTV:**
  - **Wall heat conduction:** Heat transfer through the opaque portion of walls
  - **Glass heat conduction:** Heat transfer through windows and glazing systems
  - **Solar heat gain through windows:** Heat from solar radiation entering through glazed surfaces

$$\text{OTTV} = a(1 - \text{WWR})U_w + b(\text{WWR})U_f + c(\text{WWR})(\text{CF})(\text{SC})$$

- OTTV: Overall thermal transfer value (W/m<sup>2</sup>)
- WWR: Window-to-wall ratio (fenestration area / gross area of external wall)
- U<sub>w</sub>: Thermal transmittance of opaque roof (W/m<sup>2</sup>.K)
- U<sub>f</sub>: Thermal transmittance of fenestration (W/m<sup>2</sup>.K)
- SC: Shading coefficient of fenestration
- CF: Solar correction factor for fenestration (based on the orientation and slope)
- a, b, c = multiplying factors determined based on the specific country/location

Source: Building and Construction Authority, Government of Singapore

# OVERALL THERMAL TRANSFER VALUE

## OTTV: Sample calculation

For example, taking a building with the following specifications:

- **Wall (opaque)**
  - Area of wall ( $A_w$ ) = 50m<sup>2</sup>
  - Thermal transmittance of wall material ( $U_w$ ) = 1.5W/m<sup>2</sup>·K
- **Window (glazing)**
  - Area of window ( $A_f$ ) = 10m<sup>2</sup> (On north façade)
  - Thermal transmittance of glazing ( $U_f$ ) = 5.0W/m<sup>2</sup>·K
  - Shading coefficient (SC) = 0.8
  - Window-to-wall ratio (WWR) = 0.2
  - CF = 0.8
- **Multiplier factors values for Singapore:**
  - a = 12
  - b = 3.4
  - c = 211

$$OTTV = a(1 - WWR)U_w + b(WWR)U_f + c(WWR)(CF)(SC)$$

Wall heat transfer:  
 $12 \times 0.8 \times 1.5 = 14.4 \text{ W/m}^2$

Glazing heat transfer:  
 $3.4 \times 0.2 \times 5 = 3.4 \text{ W/m}^2$

Solar heat gain through windows:  
 $211 \times 0.2 \times 0.8 \times 0.8 = 27 \text{ W/m}^2$

$$OTTV = 25 + 16.67 + 0.53 = 44.8 \text{ W/m}^2$$

Source: Building and Construction Authority, Government of Singapore

# Thank you!

For more information, visit us at <https://ALCBT.GGGI.ORG>  
or scan the QR code below



## IKI Independent Complaint Mechanism

Any person who believes they may be harmed by an IKI project or who wish to report corruption or the misuse of funds, can lodge a complaint to the IKI Independent Complaint Mechanism at [IKI-complaints@z-u-g.org](mailto:IKI-complaints@z-u-g.org). The IKI complaint mechanism has a panel of independent experts who will investigate the complaint. In the course of the investigation, we will consult with the complainant so as to avoid unnecessary risks for the complainant. More information can be found at <https://www.international-climate-initiative.com/en/about-iki/values-responsibility/independent-complaint-mechanism/>.

 [www.gggi.org](http://www.gggi.org)

 [@gggi\\_hq](https://twitter.com/gggi_hq)

 [@GGGIHQ](https://www.instagram.com/gggi_hq)

 [@GGGIHQ](https://www.facebook.com/gggi_hq)

 [@gggi\\_hq](https://www.linkedin.com/company/gggi_hq)

 [@GGGIMedia](https://www.youtube.com/channel/UCGgI-Media)



Supported by:



on the basis of a decision  
by the German Bundestag



## 2.2 Solar Passive Design

November 2024



Supported by:



on the basis of a decision  
by the German Bundestag

# WHAT WILL YOU LEARN?

Understanding the Climate

01

Building Massing and Orientation

02

Optimizing Building Envelope - Windows for Better Daylight and Minimum Heat Gain

03

Optimizing Building Envelope - Windows for Better Natural Ventilation

04

Solar Shading

05

Optimizing Building Envelope - Walls and Roofs

06

Building Envelope Features for Different Climates

07

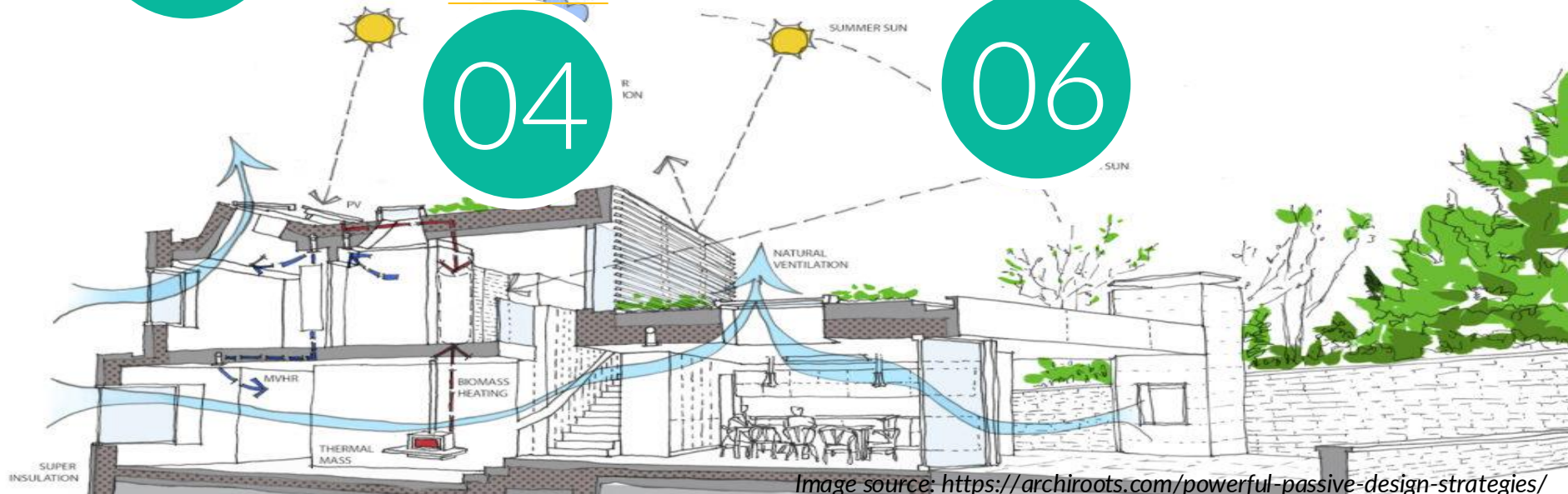

Image source: <https://archiroots.com/powerful-passive-design-strategies/>

# Understanding the Climate

Temperature, Humidity, Wind and Solar Radiation



Image source: <https://elemental.green/passive-solar-home-design->

# ROLE OF MICROCLIMATE

Determines the overall layout and comfort in buildings

Microclimate of a building affects energy transfer through building and how people respond to it

Local conditions that contribute to microclimate



Temperature



Air



Humidity

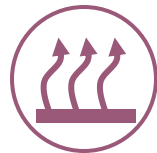

Radiation

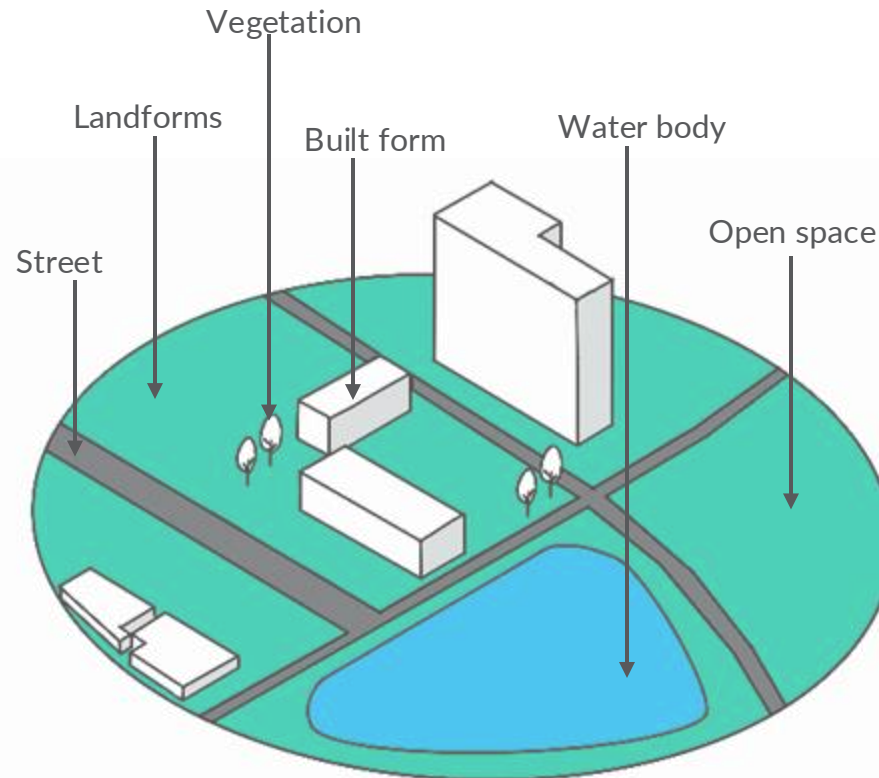

Factors affecting microclimate of a site



Image source: SM Solutions

Open courtyards with combination of pervious and impervious materials add character to the building

# CLIMATE ANALYSIS

## Example: New Delhi, India

- To conduct a climate analysis, representative [climate data of the location for the past 10–15 years](#) is needed
- Several tools can assist in climate analysis. These tools use hourly weather data files as input
- The [latest available weather files](#) should be used for climate analysis
- One potential source for weather files is <https://climate.onebuilding.org/default.html>

- Location: New Delhi, India
- Latitude: 28.6139° N
- Longitude: 77.2088° E
- Altitude: 216 m
- Climatic zone: Composite
- Climate summary:
  - Average yearly temperature: 24.8 °C
  - Hottest temperature (99%): 40.8 °C
  - Coldest temperature (1%): 7.1 °C
  - Annual cumulative horizontal solar radiation: 1909.09 kWh/m<sup>2</sup>

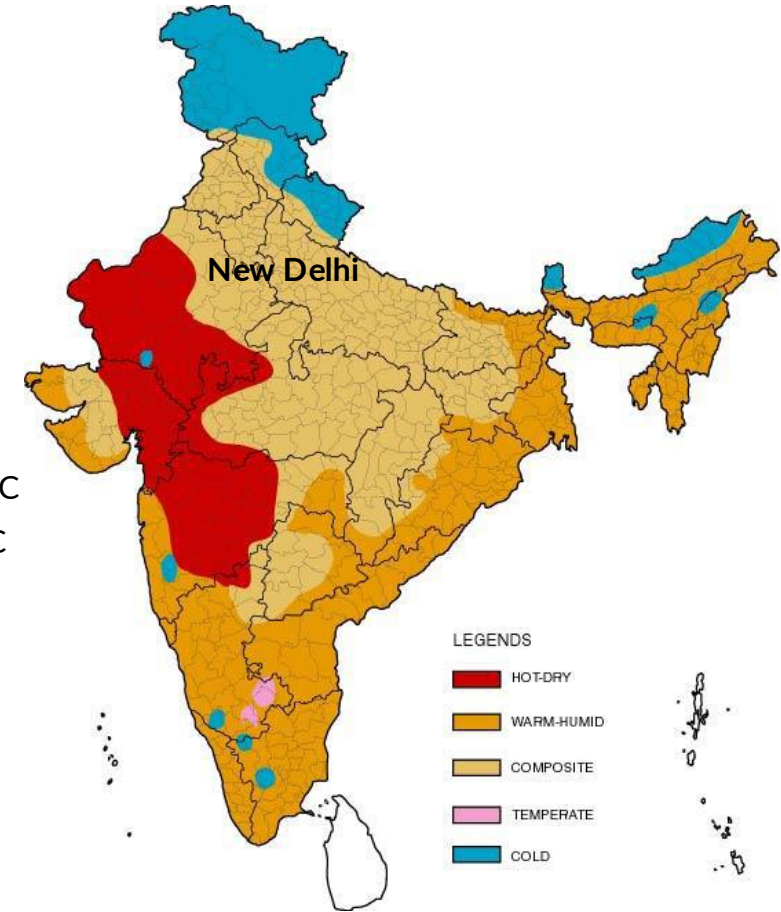

Source: Bureau of Indian Standards, Government of India, 2016b

# TEMPERATURE AND RELATIVE HUMIDITY

New Delhi, India: Seasonal variations

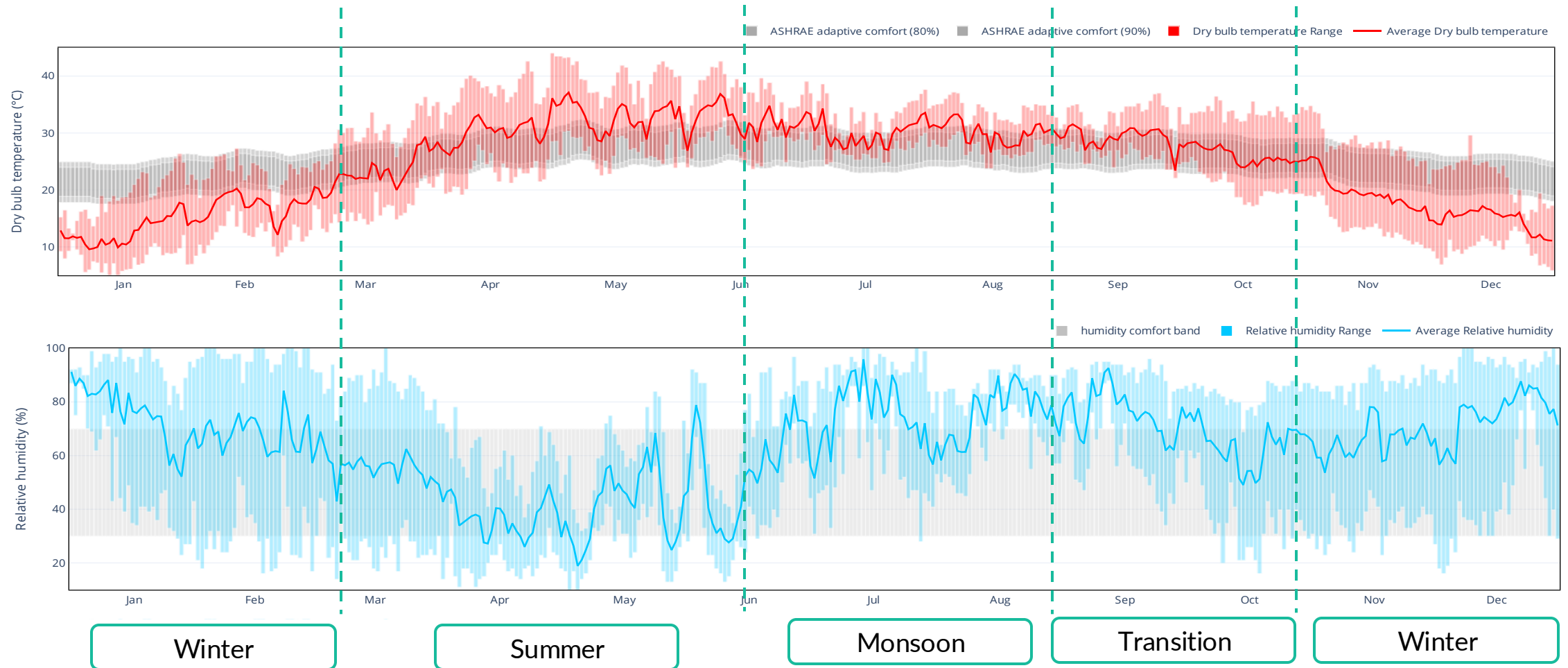

Source: <https://clima.cbe.berkeley.edu/>

# CLIMATE ANALYSIS

## New Delhi, India: Air temperature – hourly diurnal

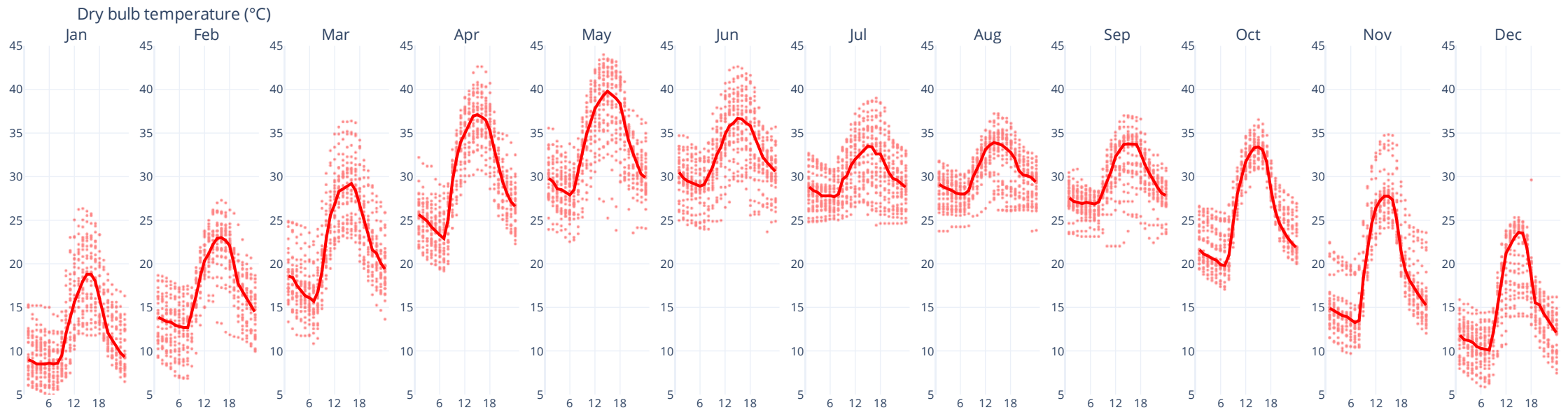

Overview of month-wise hourly average temperature variations to understand the need for cooling and heating

Source: <https://clima.cbe.berkeley.edu/>

# WIND SPEED AND DIRECTION

New Delhi, India

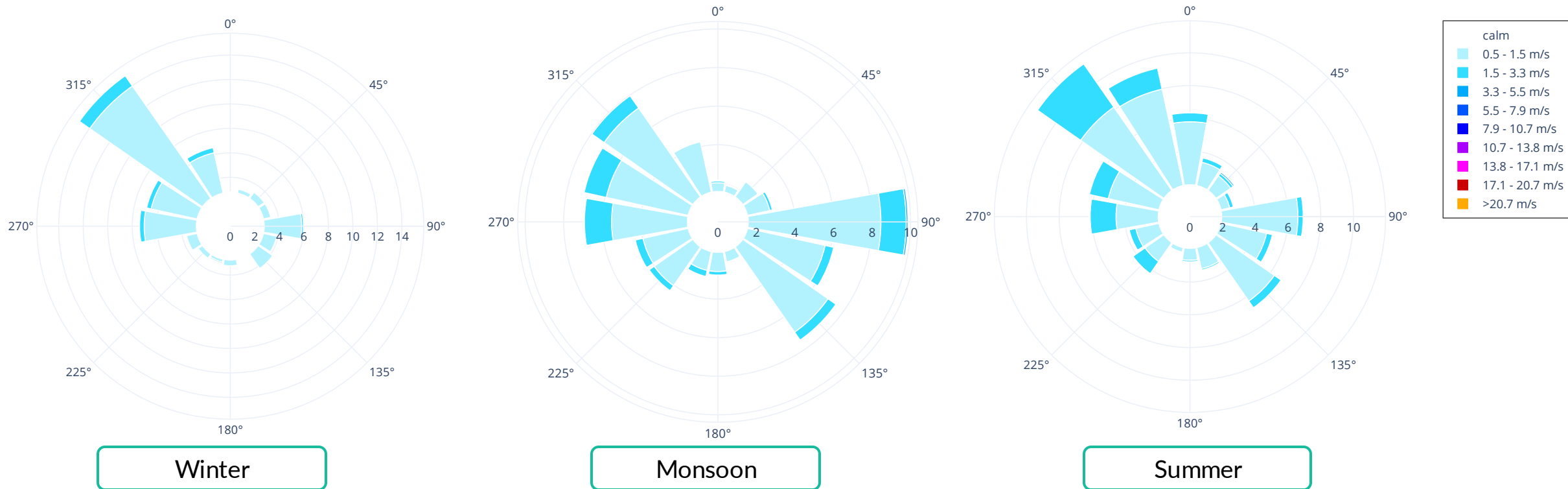

Overview of wind velocity and direction of wind for different seasons to draw inferences for building orientation and placement of openings for maximizing or minimizing natural ventilation

Source: <https://clima.cbe.berkeley.edu/>

# SOLAR RADIATION

New Delhi, India

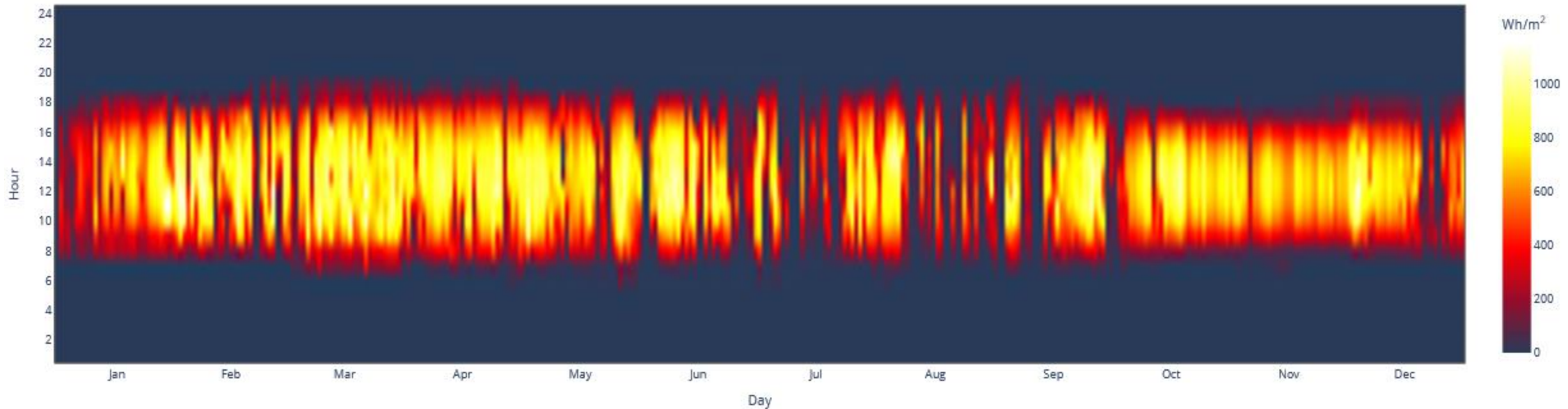

Overview of annual solar radiation for different months helps plan for solar protection or higher solar exposure, and estimates the energy generation potential from solar energy

Source: <https://clima.cbe.berkeley.edu/>

# SOLAR RADIATION

New Delhi, India

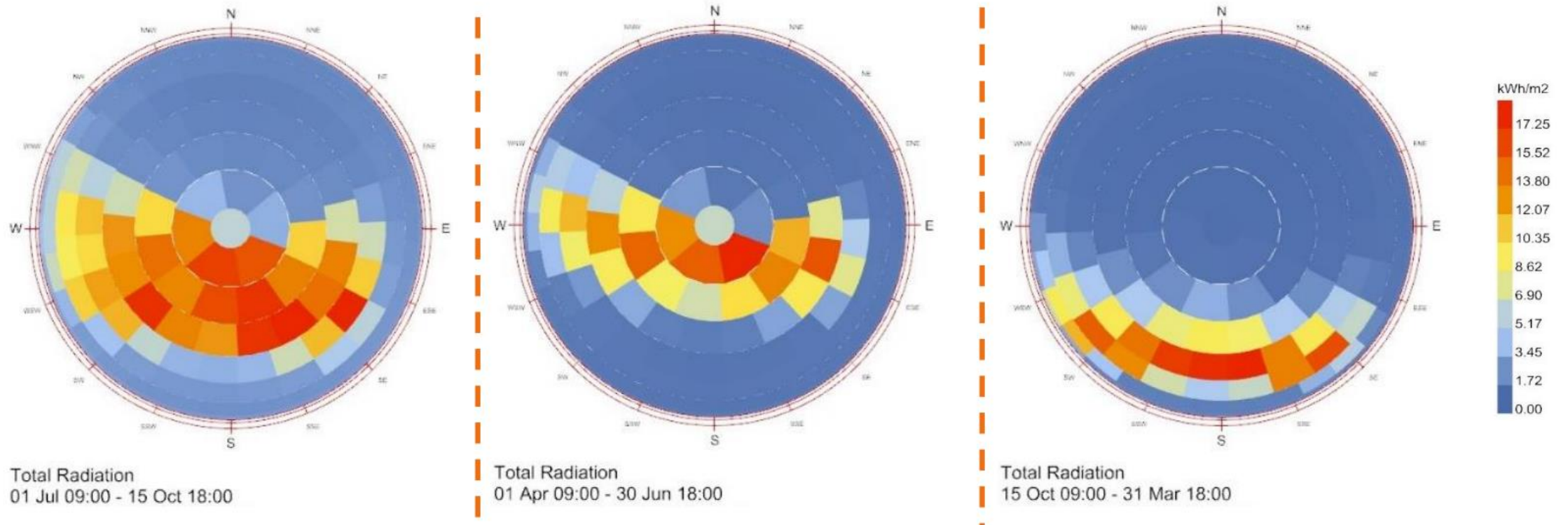

Overview of solar radiation on different façades in different seasons, to plan for solar protection strategies

Source: CEPT University, 2022

# CLIMATE ANALYSES

## New Delhi, India: Inferences from temperature, humidity and wind analyses

### Temperature and humidity analysis:

- **Hot and dry summer** season with **temperatures reaching up to 44°C**
- It is followed by the monsoon season with **temperatures ranging from 25°C to 37°C, with average humidity above 70%**
- Winter season last for four months, when **temperatures go below 10°C**
- During the **transition months**, there is **higher diurnal variation** in the outdoor dry bulb temperature. By introducing night purging, the overall cooling demand can be reduced or eliminated
- However, during the winter months, night purging can lead to higher heat loss from the spaces

### Wind analysis:

- The wind speed in New Delhi is predominantly from the north-west and northern winds with an average wind velocity of 5.85 m/s. In passive strategies like mix mode and night purging, with the consideration of temperature of wind, openings on the north-west façade can be optimized

# CLIMATE ANALYSES

## New Delhi, India: Inferences from solar radiation analysis

### Solar radiation analysis:

- The average global horizontal radiation is  $217.21 \text{ Wh/m}^2$  and maximum global horizontal radiation is  $987 \text{ Wh/m}^2$ . This shows a **high potential for the installation of solar photovoltaic panels for electricity generation** throughout the year
- During summer, **maximum radiation is received on the west**; this will require a strategy of shading from the lower altitude sun
- In the winter months the south façade will receive higher solar radiation, this can be favorable to cut down the heating load during these months
- By providing overhangs on the south façade windows, we can cut down the higher altitude sun in the summer months and take advantage of the lower altitude sun in the winter months

# CLIMATE ANALYSES

## New Delhi, India: Thermal comfort analysis

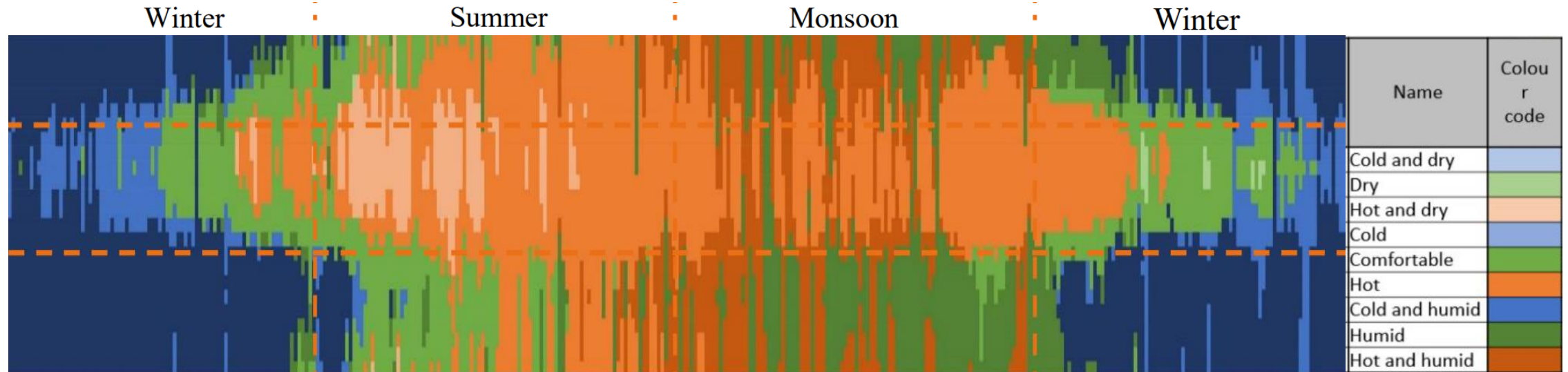

- Based on outdoor dry bulb temperature and relative humidity, 8,760 hours of the year can be divided into nine thermal conditions
- Here, the comfortable condition is at **21.5°C–28.5°C** and **30%–70% relative humidity**
- The graph above indicates that during summer months, the daytime is hot and dry, while during monsoon months, it is warm and humid

Source: CEPT University, 2022

# CLIMATE ANALYSES

## New Delhi, India: Thermal comfort analysis

Correlating the key inferences with the building during operating hours

(9am to 6pm for a typical office):

- Cooling required for 41% of the time
- Heating required for 11% of the time
- Natural ventilation meets the comfort requirement for 17% of the hours
- Cooling and dehumidification required for 11% of the time (mainly during the monsoon months)

\*Based on outdoor conditions; with internal loads, these requirements will change

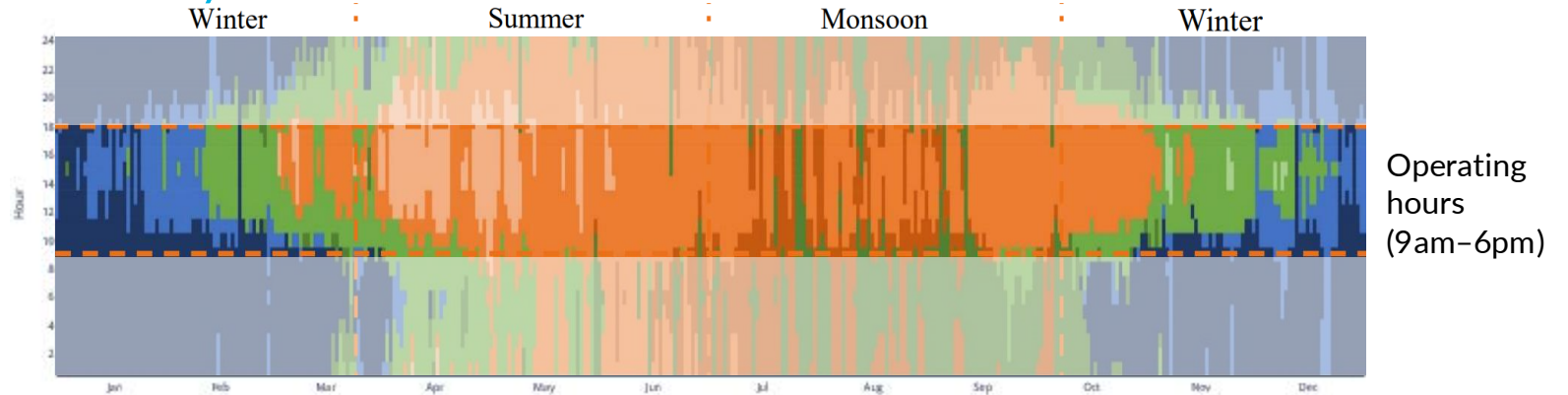

N o.	Name	Colour code	Quality	Temperature range (°C)	RH range (%)	3650 operating Hours		Strategies Required
						Number of Hours	Hours in %	
1	Cold and dry		Low RH & Low DBT	0 - 21.5	0-30	0	0.0	Humidification & Heating
2	Dry		Low RH & Moderate DBT	21.5 - 28.5	0-30	18	0.5	Humidification
3	Hot and dry		Low RH & High DBT	28.5 - 44	0-30	266	7.3	Humidification and Cooling
4	Cold		Moderate RH & Low DBT	0 - 21.5	30-70	393	10.8	Heating
5	Comfortable		Moderate RH & Moderate DBT	21.5 - 28.5	30-70	620	17.0	Natural Ventilation
6	Hot		Moderate RH & High DBT	28.5 - 44	30-70	1528	41.9	Cooling
7	Cold and humid		High RH & Low DBT	0 - 21.5	70-100	413	11.3	Dehumidification & Heating
8	Humid		High RH & Moderate DBT	21.5 - 28.5	70-100	151	4.1	Dehumidification
9	Hot and humid		High RH & High DBT	28.5 - 44	70-100	261	7.2	Dehumidification & Cooling

Source: CEPT University, 2022

# SUN PATH ANALYSIS

For orientation and massing

Understanding of the sun's movement around the building

Which façades will be exposed to the sun?

Shadows of the adjoining buildings and the proposed building itself

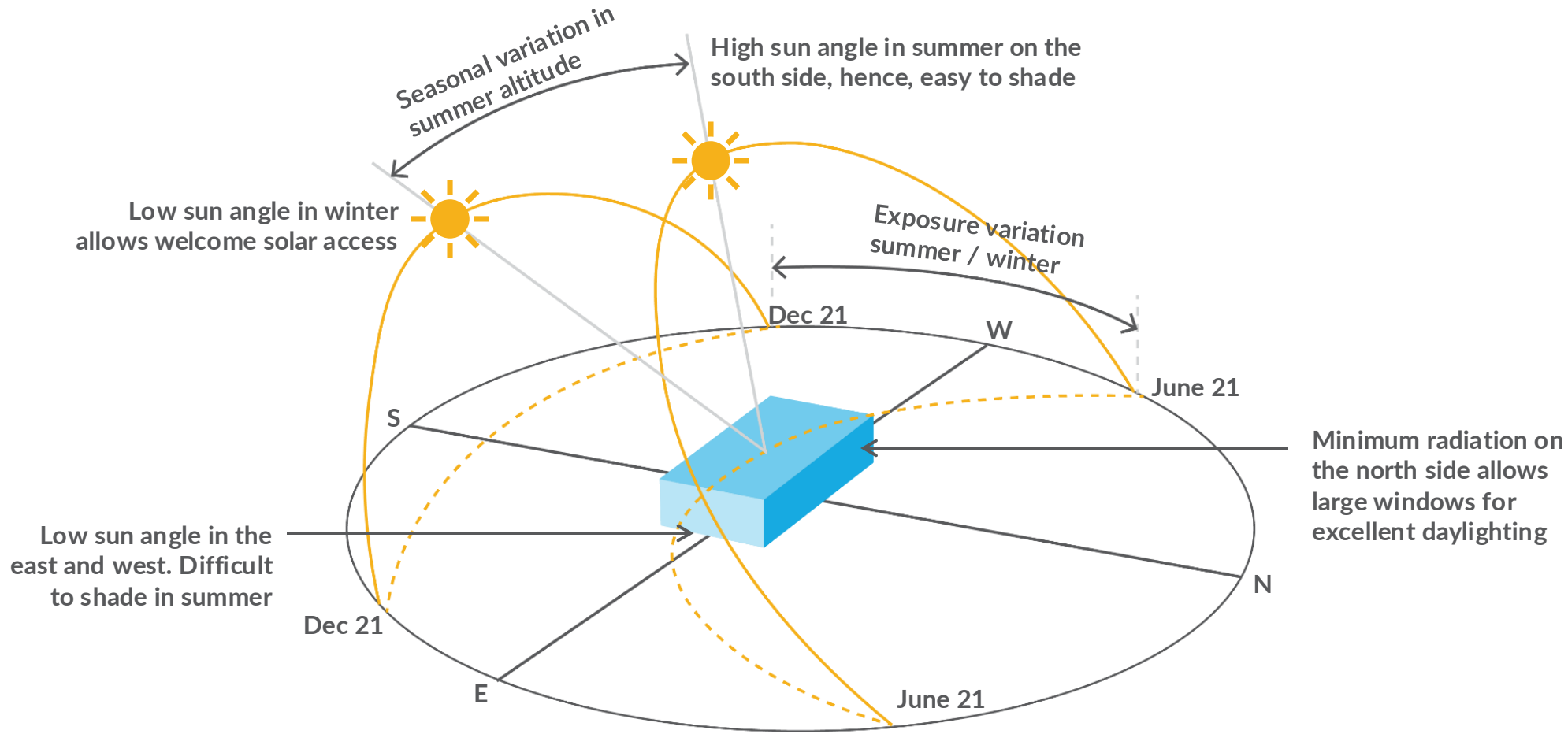

# CLIMATE

## Example: Phnom Penh, Cambodia

- Location: Phnom Penh, Cambodia
- Latitude: 13.41100°N
- Longitude: 103.8130°E
- Altitude: 12.2m
- Climatic zone: Hot and humid

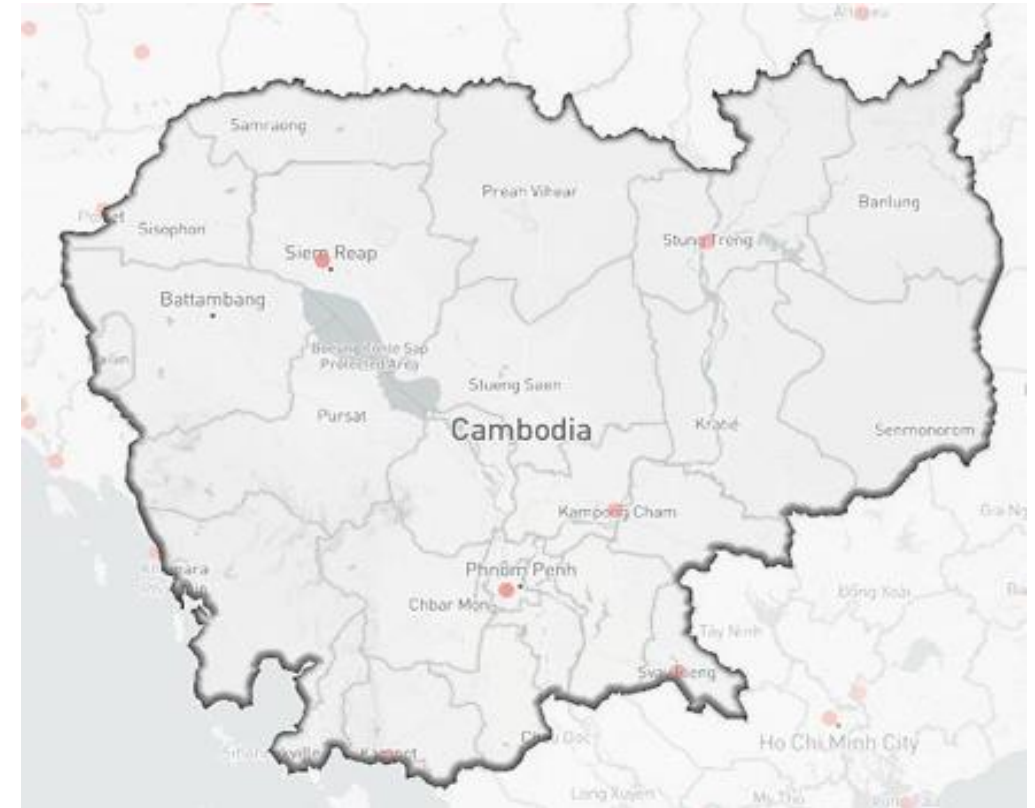

Phnom Penh

Sources: UNEP; ESCAP; Cool Coalition; Ministry of Environment, Government of Cambodia

# SUN PATH AND SOLAR RADIATION

Phnom Penh, Cambodia

- Maximum daily direct solar radiation: 921 Wh/m<sup>2</sup>
- Maximum daily diffused solar radiation: 386 Wh/m<sup>2</sup>
- Diffused solar radiation higher during the months of June to September, coinciding with a higher level of humidity and cloudiness
- Solar intensity is notably high from 11:00 am to 6:00 pm from February to October, and from 1:00 pm to 6:00 pm from November to January

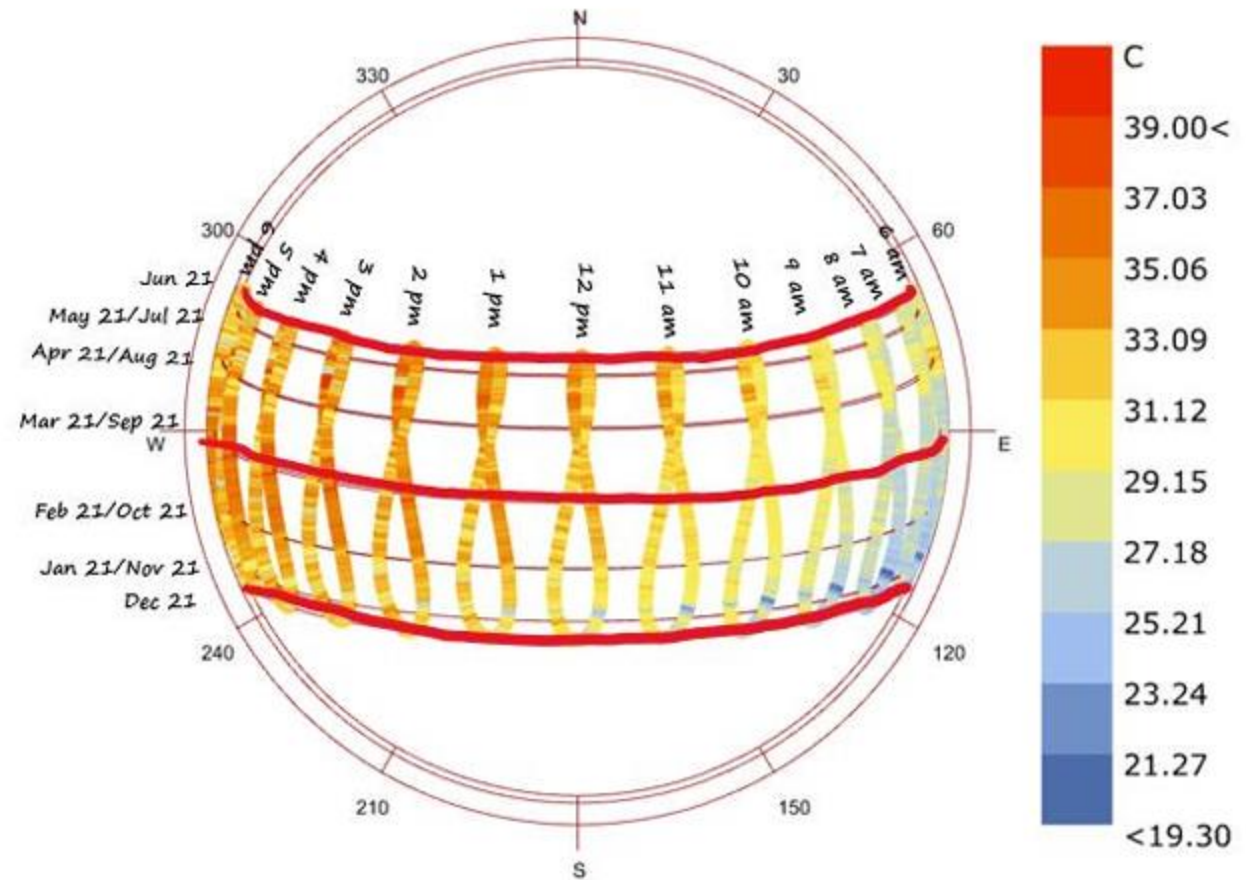

# DIRECT SOLAR RADIATION

Phnom Penh, Cambodia

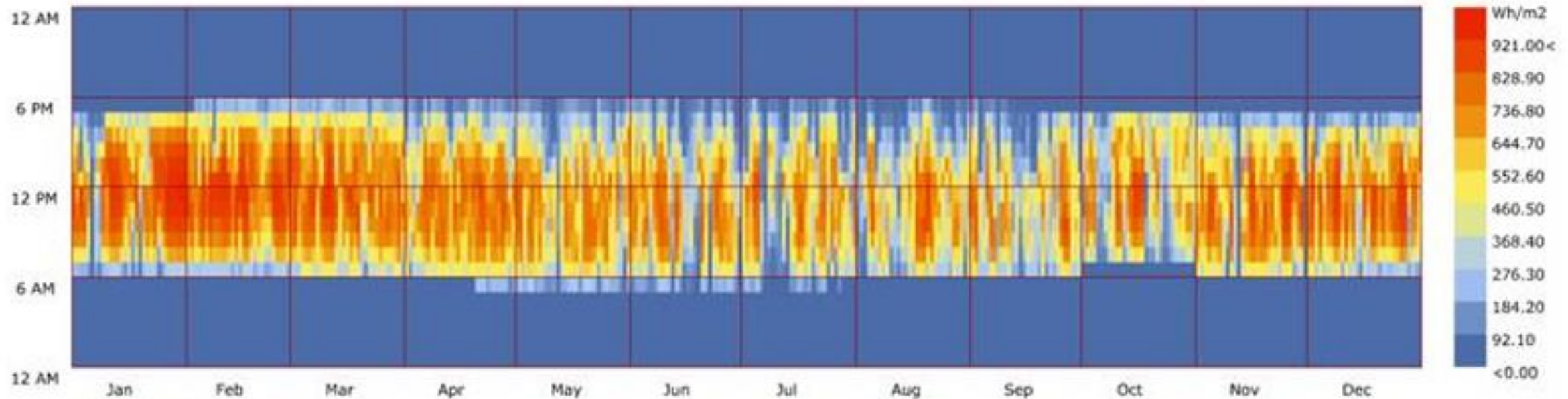

Direct Normal Radiation (Wh/m2) - Hourly  
Phnom.Penh.Intl.AP\_PP\_KHM  
1 JAN 1:00 - 31 DEC 24:00

# PRECIPITATION

## Phnom Penh, Cambodia

- Average annual precipitation of about **1,432 mm** (56.4 inches)
- **February is the driest** month, with an average precipitation of 9 mm (0.4 inches) recorded over 1.87 days. Conversely, **September** experiences the highest amount of precipitation, with an average of 255 mm (10.0 inches) recorded over 26.07 days

	January	February	March	April	May	June	July	August	September	October	November	December
Precipitation / Rainfall	17	9	41	86	163	157	159	185	255	246	86	28
mm (in)	(0)	(0)	(1)	(3)	(6)	(6)	(6)	(7)	(10)	(9)	(3)	(1)
Humidity(%)	60%	57%	60%	66%	75%	77%	77%	78%	82%	83%	76%	66%
Rainy days (d)	2	1	5	11	17	17	18	19	20	18	9	4

# CLIMATE ANALYSIS

## Phnom Penh, Cambodia: Temperature variation

- High dry bulb temperatures exceeding 31°C from February to August
- Universal Thermal Climate Index (UTCI), which factors in parameters such as humidity and wind speed, shows that the felt temperature **surpasses 31°C** throughout the day from April to July, September and October

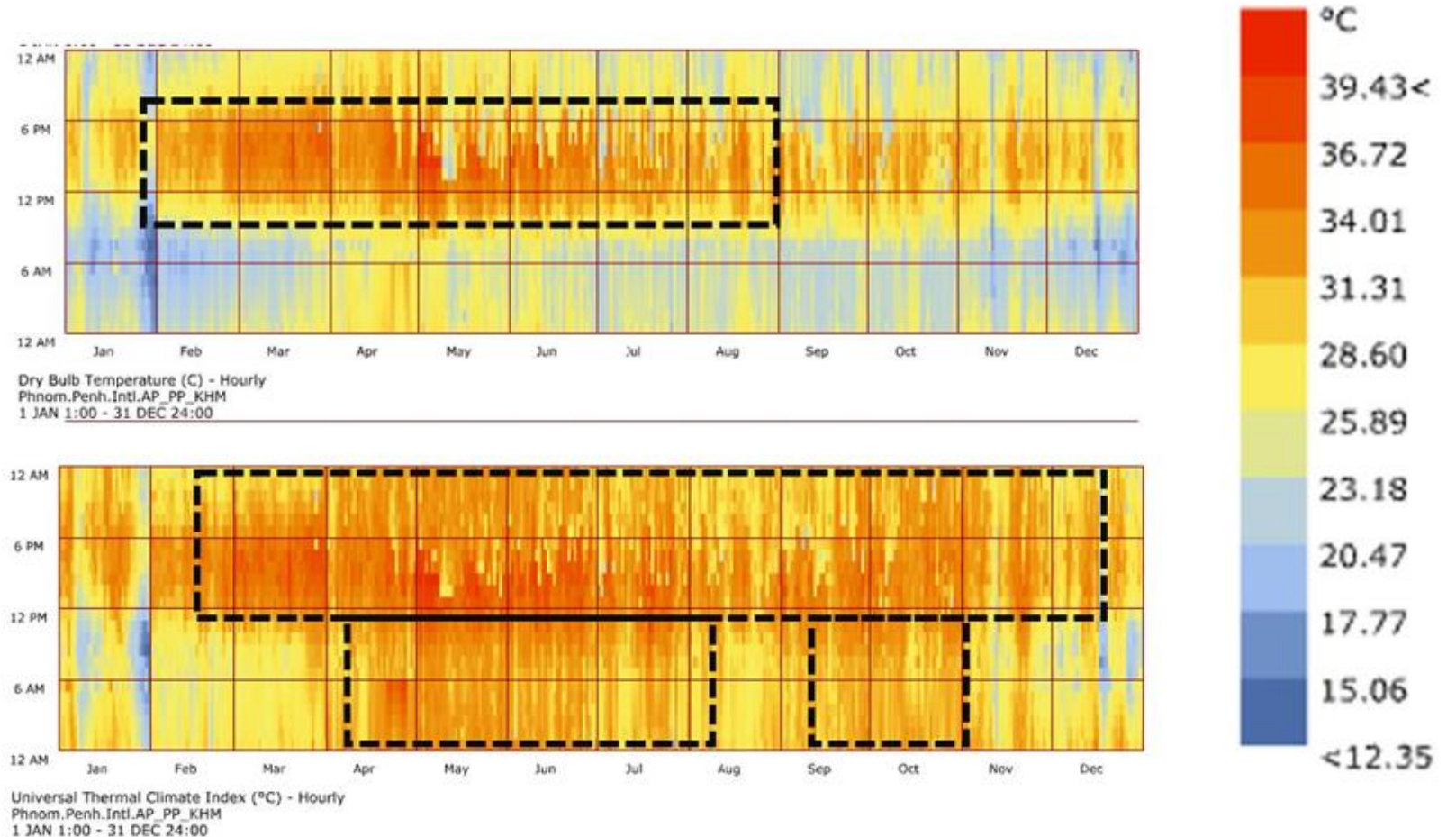

# CLIMATE ANALYSIS

## Phnom Penh, Cambodia: Relative humidity

- High levels of relative humidity (RH) throughout the year
- During nighttime, the RH remains consistently above 70%. From 6:00 pm to 12:00 am, elevated RH levels persist between May and November
- On average, humidity remains high from May to November. However, from November to April, the RH ranges between 40% and 70% during the day

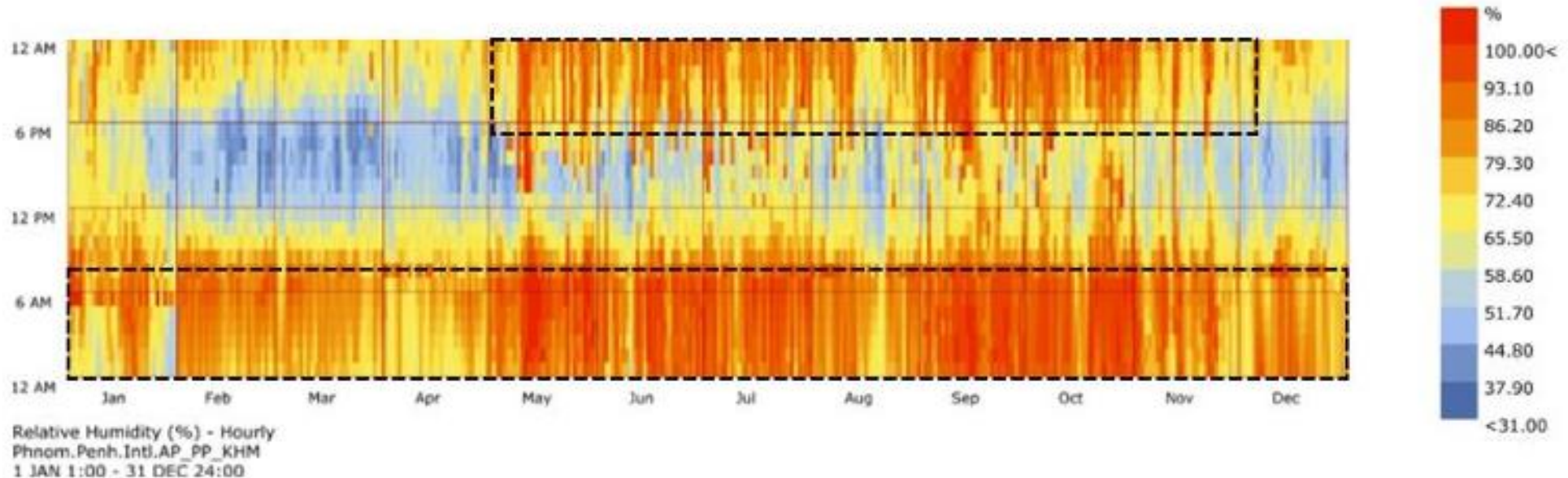

# CLIMATE ANALYSIS

## Phnom Penh, Cambodia: Wind analysis

- Generally, wind peaks in the southwest, south and southeast directions from February to September
- From October to January, the wind direction shifts toward the north and northeast
- Relative humidity exceeds 70%
- Average temperature of the wind throughout the year in Phnom Penh ranges from 24°C to 38°C

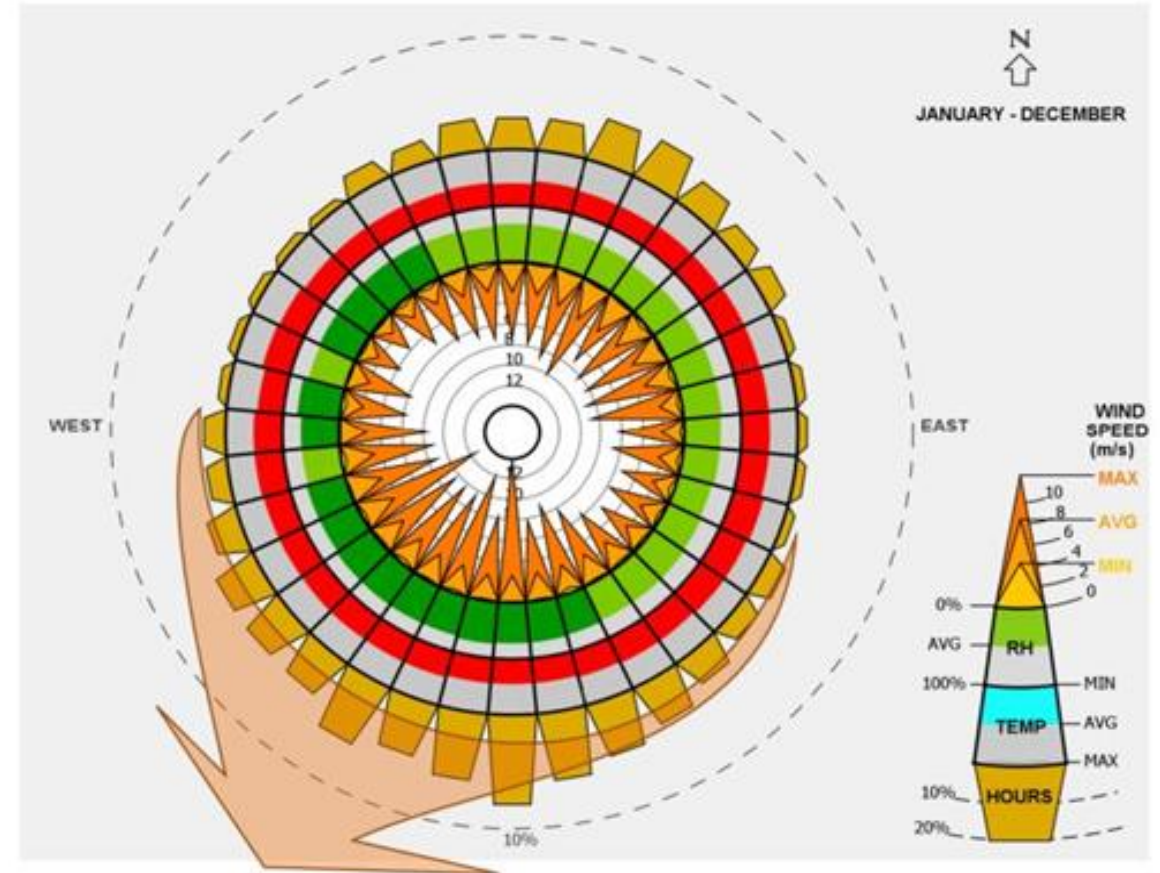

### TEMPERATURE (Deg. C)

■	< 0
■	0 - 22
■	22 - 24
■	24 - 38
■	> 38

### RELATIVE HUMIDITY (%)

■	<30
■	30-70
■	>70

# Building Massing and Orientation

Harnessing Daylight and Natural Ventilation

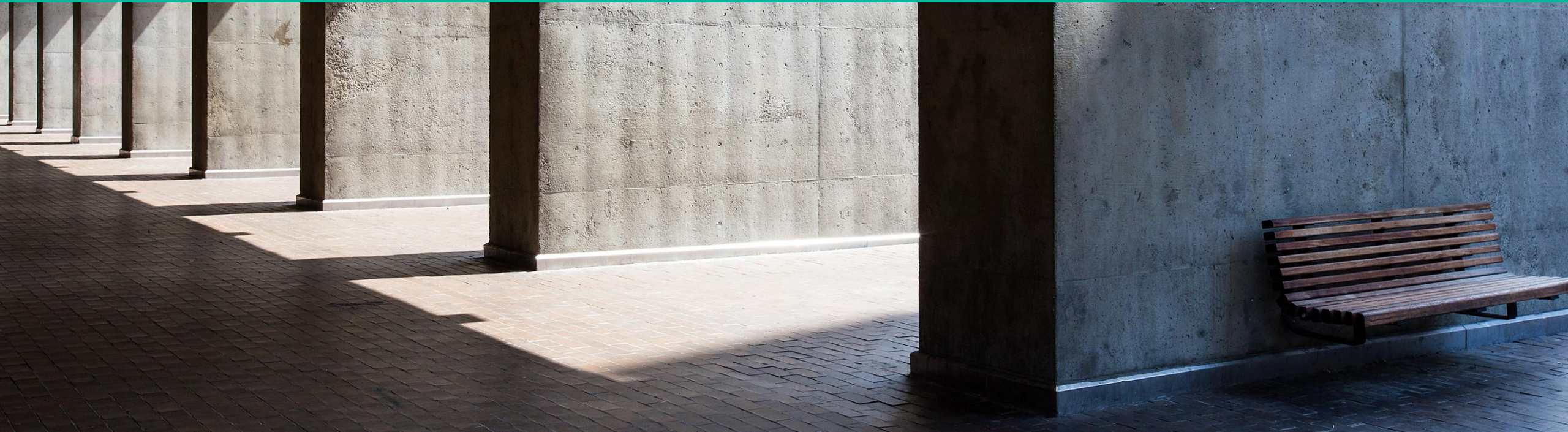

# MASSING AND ORIENTATION

For harnessing daylight and natural ventilation

- **Orientation** is the positioning of a building in relation to seasonal variations in the sun's path, as well as prevailing wind patterns
- **Massing** is the overall shape and size of the building

Climate-appropriate building massing and orientation helps harness daylight, solar and wind energy for comfort, and reduce the building's energy dependence

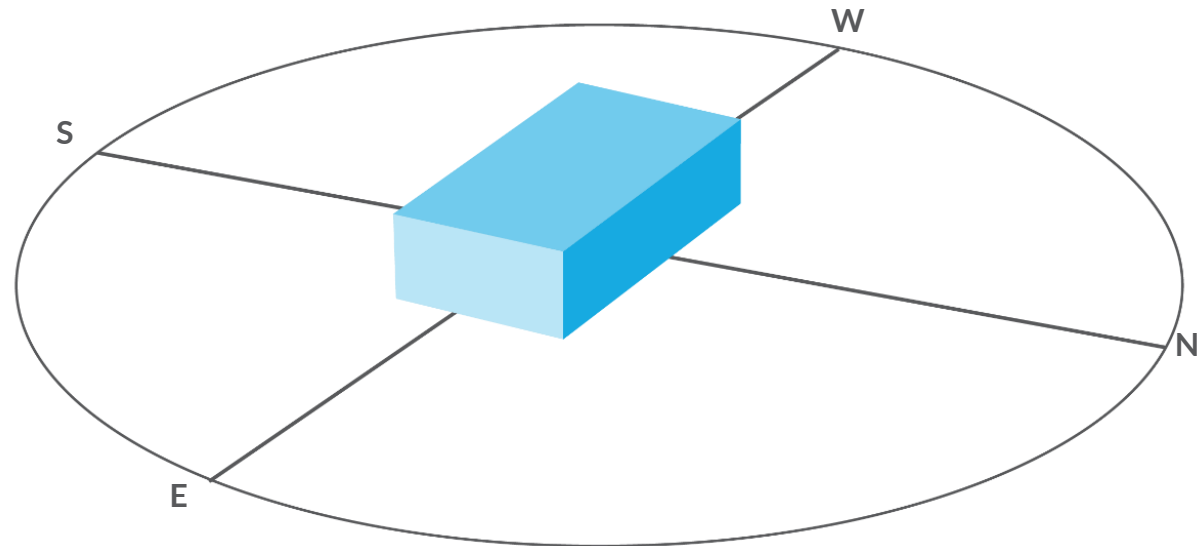

# BUILDING ORIENTATION

To harness daylight and natural ventilation

- Requirements to manage solar gains and utilize wind flows may lead to conflicting results
- Designers must **strike a balance** between orientation with respect to the sun and wind flow
- Critical façades and windows should be well-shaded to avoid solar radiation

Longer façades, fenestration and habitable spaces are ideally located in the north and south directions – less solar radiation BUT great for daylight access

East and west façades are kept small

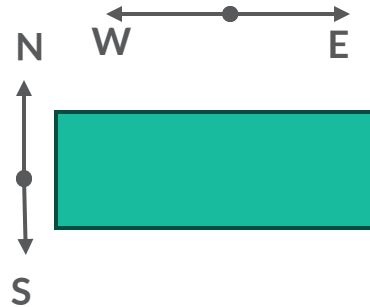

In India, the preferred orientation is toward the north and south directions, with respect to the sun's path

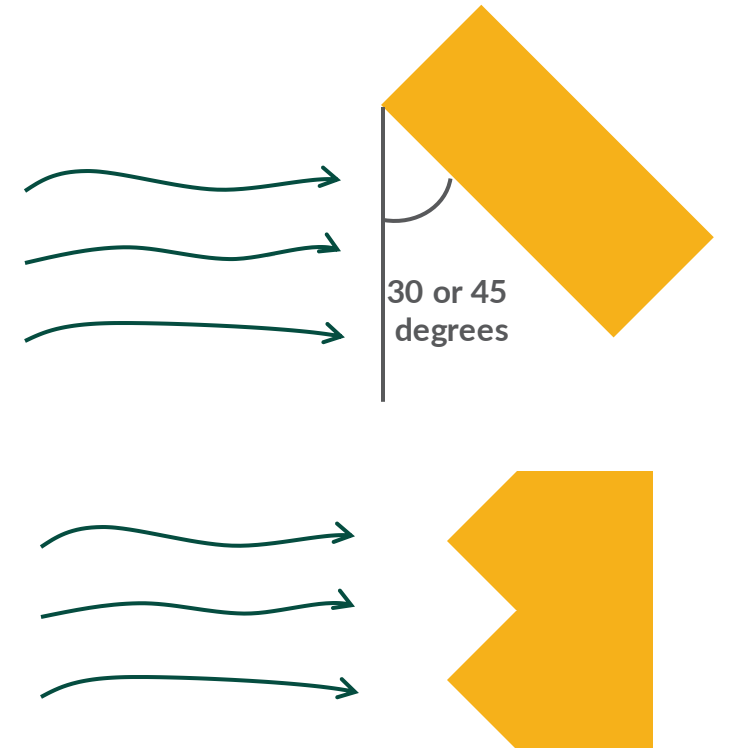

For proper utilization of the wind, the longer façade of the buildings needs to be oriented at an angle (usually  $\pm 45$  degrees) to the prevailing wind direction

# BUILDING FLOOR PLATES

For harnessing daylight and natural ventilation

Different types of building floor plates for good daylight and natural ventilation



N  
↑

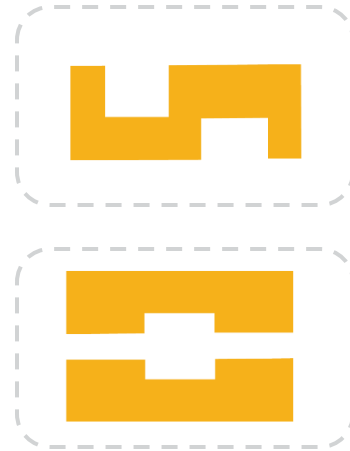

North-south orientation can be used in creative ways to generate a variety of built and open spaces

North-south orientation can also be used in case of unfavourable orientation of the land

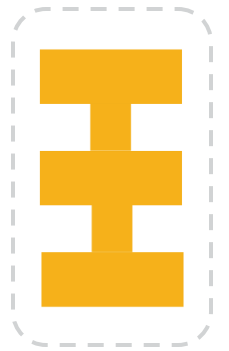

N  
↑

# PASSIVE DESIGN STRATEGIES

## Massing strategies

- **Mutual shading** of built forms
- Compact forms are ideal for extreme climates
  - Low surface area to volume (**S/V**) ratio
  - Low perimeter to area (**P/A**) ratio
  - **Compact forms** gain less heat during daytime and lose less heat at nighttime

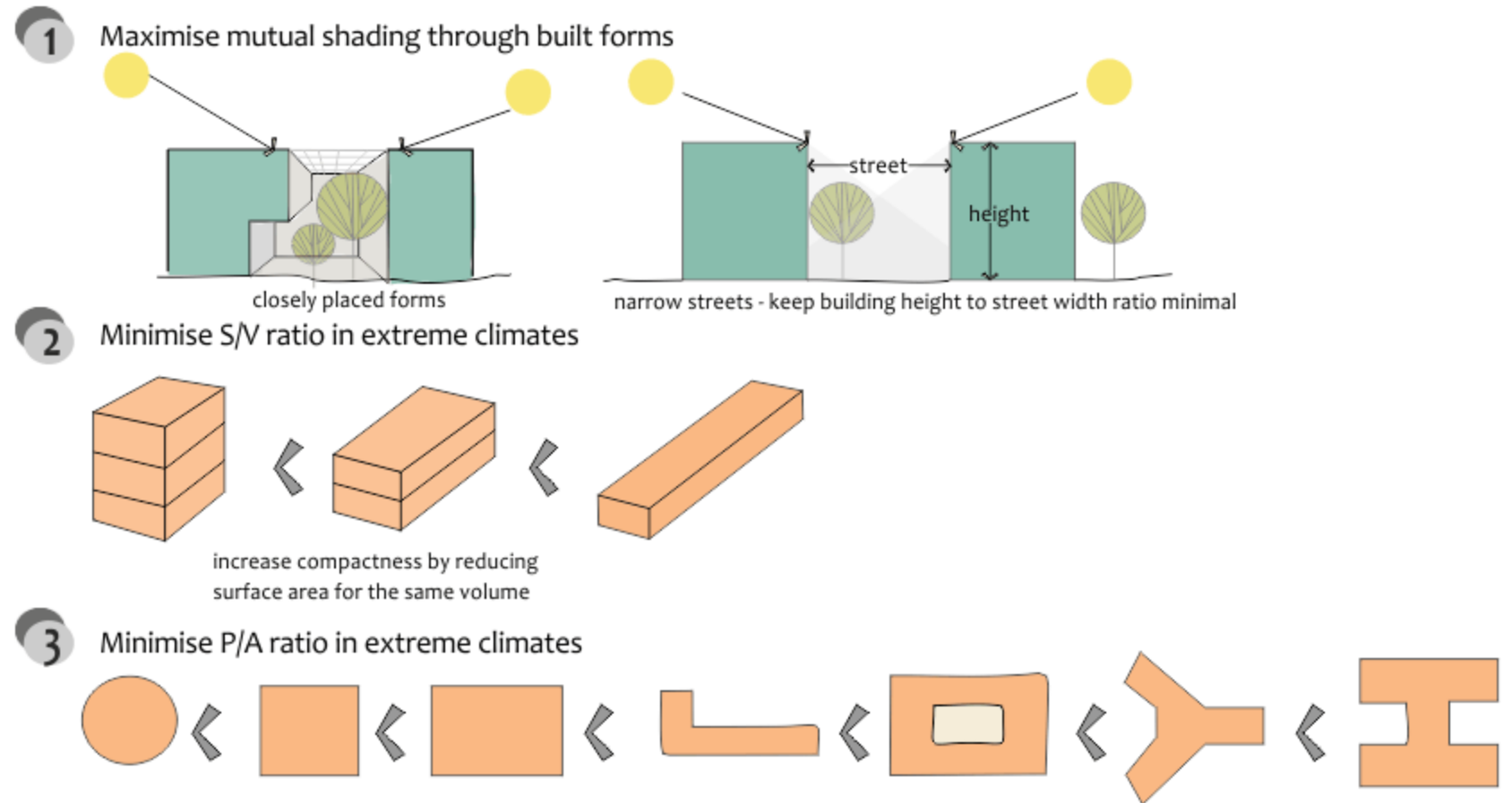
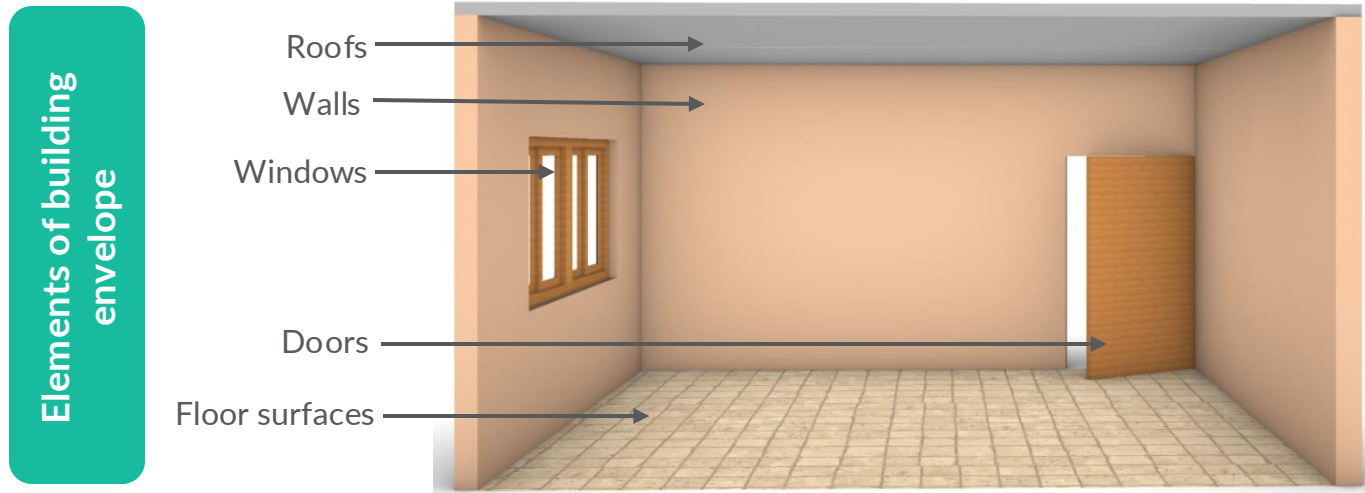

Image source: <https://nzeb.in/knowledge-centre/passive-design/form-orientation/>

# ENVELOPE DESIGN

## Significance

- Envelope design is a major factor in determining the amount of energy a building will use in its operation
- The overall environmental life cycle impacts, and energy costs associated with the production and transportation of different envelope materials, vary greatly
- The building envelope or 'skin' consists of structural materials and finishes that enclose space, separating inside from outside



Source: ASHRAE Journal



# Optimizing Building Envelope

Windows for Better Daylight and Minimum Heat Gain



# DAYLIGHT FACTOR AND DAYLIGHT AUTONOMY

Key performance indices for daylight

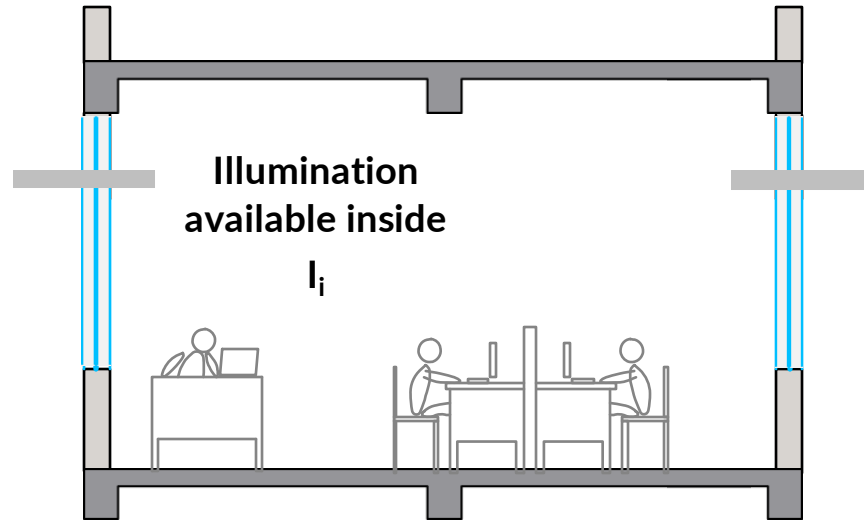

Illumination available outside  $I_o$

Daylight Factor =  $I_i / I_o$

**Daylight Autonomy:**  
Percentage of **time-in-use** that daylight levels exceed a **specified target illuminance** or lighting set-point

**TIME-IN-USE:**  
Time when building is being used  
e.g., 9 am to 6 pm

**TARGET ILLUMINANCE / LIGHTING SET-POINT:**  
Recommended illuminance (lux) levels  
e.g., lighting set-point for standard offices is 300 lux–500 lux

**Daylight Autonomy:**  
Percentage of time that an occupant can work through the use of just daylight without supplemental electric lighting

# WINDOWS

## Sizing and placement

Building spaces can be zoned to place areas requiring more daylight near the perimeter

Areas requiring less daylight placed in the center of the floor plate

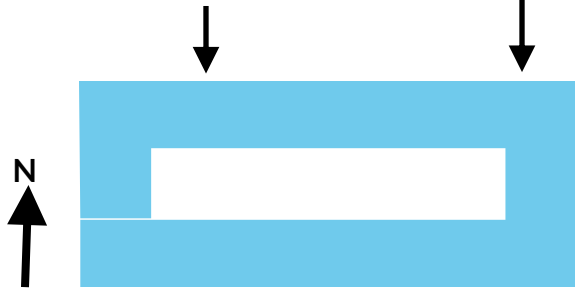

Shallow floor plates provide daylight access to greater floor area

Keep window-to-wall ratio around 20%-30%

South façade is highly exposed in winter, but less in summer. Windows can be easily shaded here

East and west façades receive high amount of radiation. Difficult to shade. Hence, less windows required here

North façade receives very little direct radiation. More windows required here

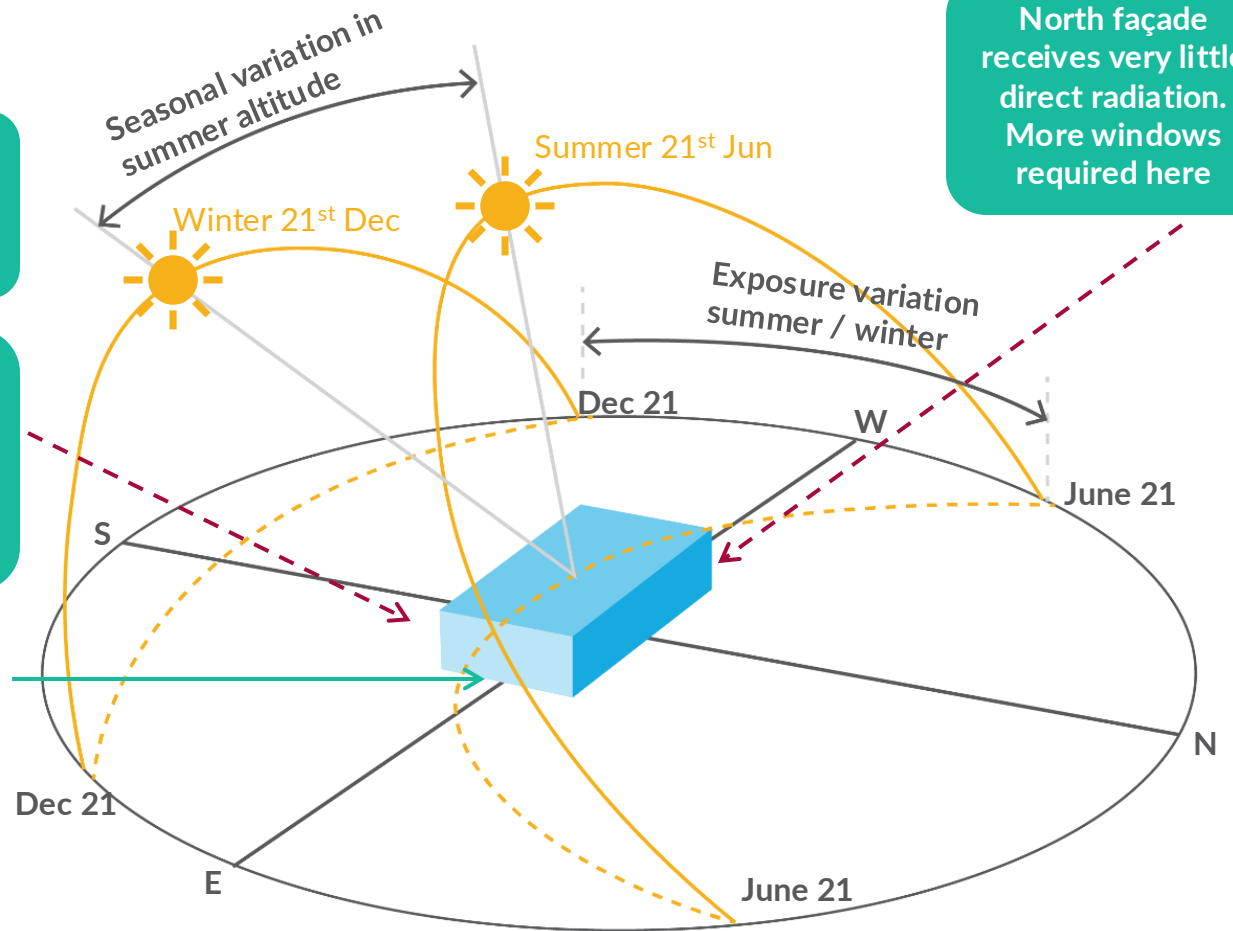

# WINDOWS

## Sizing and placement

- Daylight penetrates into a room roughly 2.5 times the height of the top of the window from the ground
- The higher the window, the deeper the daylight penetration in the room
- Usually, daylight penetration in the room is 6m–8m from the fenestration

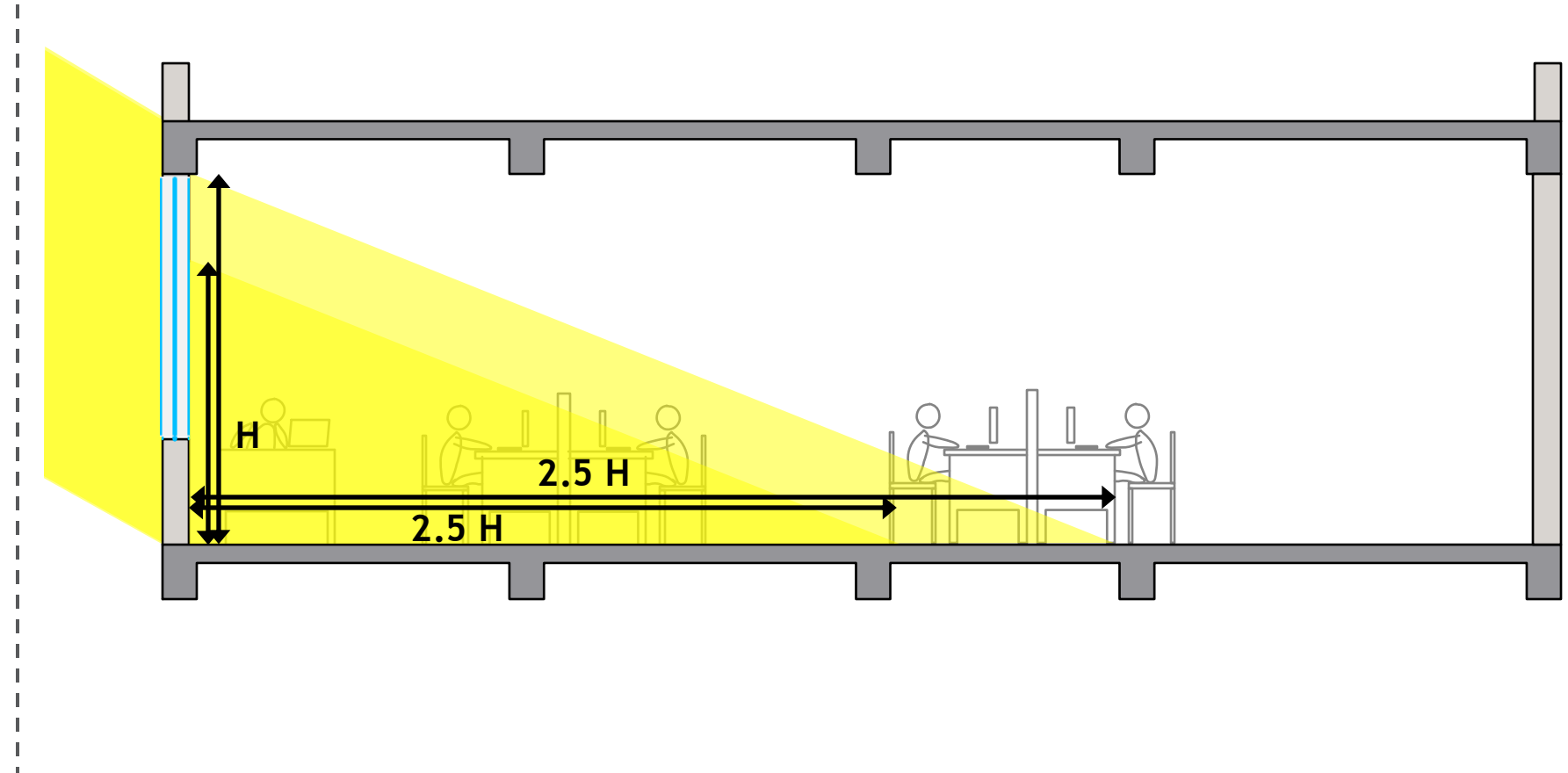

# BETTER DAYLIGHT ACCESS

## Desirable features

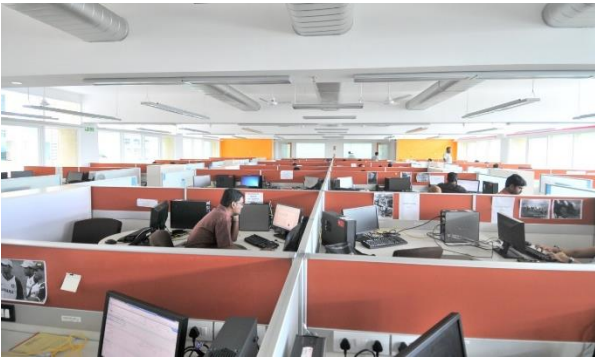

Infosys, Hyderabad Campus

Lighter colors on interior surfaces:

- Reflect light better
- Help in daylight distribution
- Reduce glare

Light shelves help in daylight distribution while providing shading

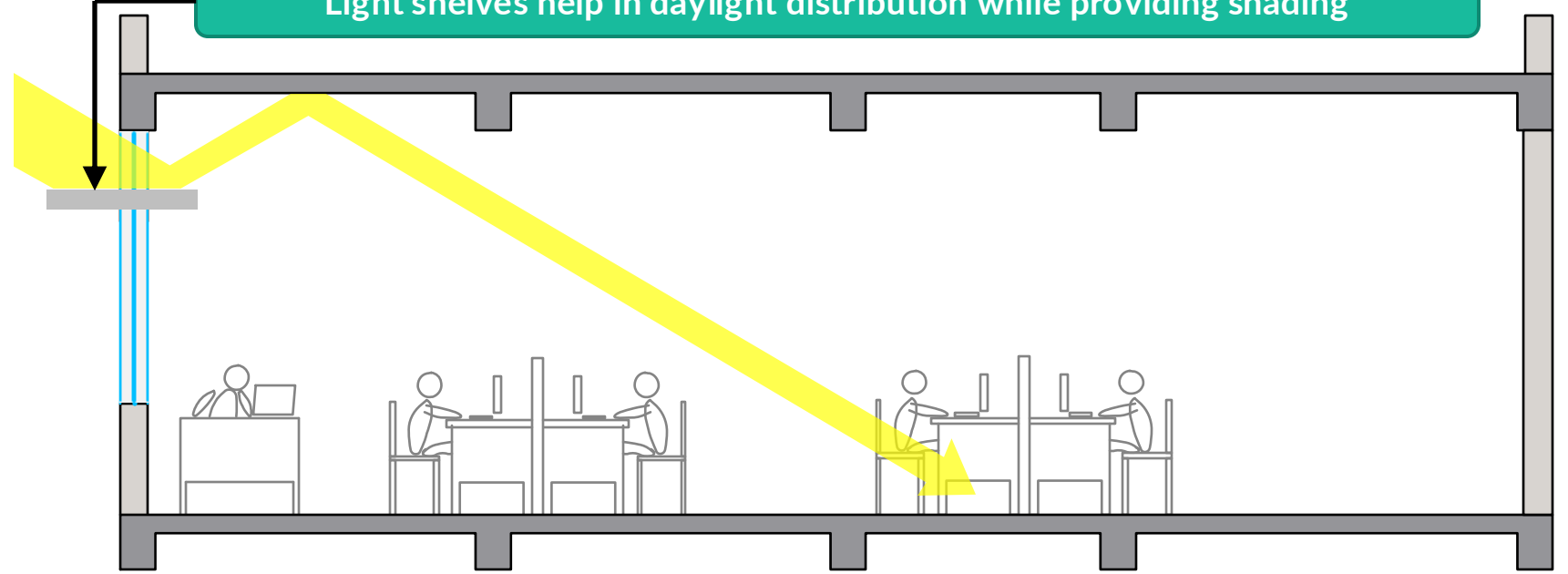

# GLASS PROPERTIES

## VLT, SHGC and U-value

VLT is the ratio of visible light that passes through a glazing unit to the total visible light incident on it

Use high VLT glass for better daylight

### FACTORS INFLUENCING VLT:

- Color of glass
- Tints and coatings on the glazing
- Number of glass panes

SHGC is the ratio of solar (radiant) heat gain that passes through the fenestration to the total incident solar radiation that falls on it

SHGC is a dimensionless number between 0 and 1. Use low-SHGC for minimum heat gain

### FACTORS INFLUENCING SHGC:

- Solar protection or shading
- Type of glass and number of panes
- Tints and coatings on the glazing
- Gas fill between glazing layers

U-value is the overall heat transfer coefficient that indicates the heat transfer from the glass through conduction

Use glass with low U-value for minimal heat gain

### FACTORS INFLUENCING U-VALUE:

- Size of the air gap between glass panes
- Coatings on the glazing
- Gas fill between glass panes
- Frame construction

Source: ASHRAE Journal

# Optimizing Building Envelope

For Better Ventilation



# NATURAL VENTILATION

## Implications

Natural ventilation (NV) is the process of supplying and removing air through an indoor space without using mechanical systems:

- NV provides acceptable indoor air quality
- NV provides thermal comfort by providing a heat transport mechanism
  - Cooling of indoor air by replacing or diluting it with outdoor air as long as outdoor temperatures are lower than indoor temperatures
  - Cooling of the building structure i.e., thermal mass of building
  - Direct cooling effect over the human body through convection and evaporation

### Buoyancy-driven natural ventilation:

- The natural movement of air through a building resulting from differences in vertical pressure developed by temperature differences in the air
- This occurs in a building by warm air escaping from openings at a substantial height on the building envelope, which draws in colder, denser outside air through the lower openings of the building

### Wind-driven natural ventilation:

- Relies on wind pressure to drive air movement
- When wind hits the windward façade, it creates a positive pressure on the façade. Similarly, as it flows away from the leeward façade, a region of lower pressure will be created. This pressure difference will force air movement

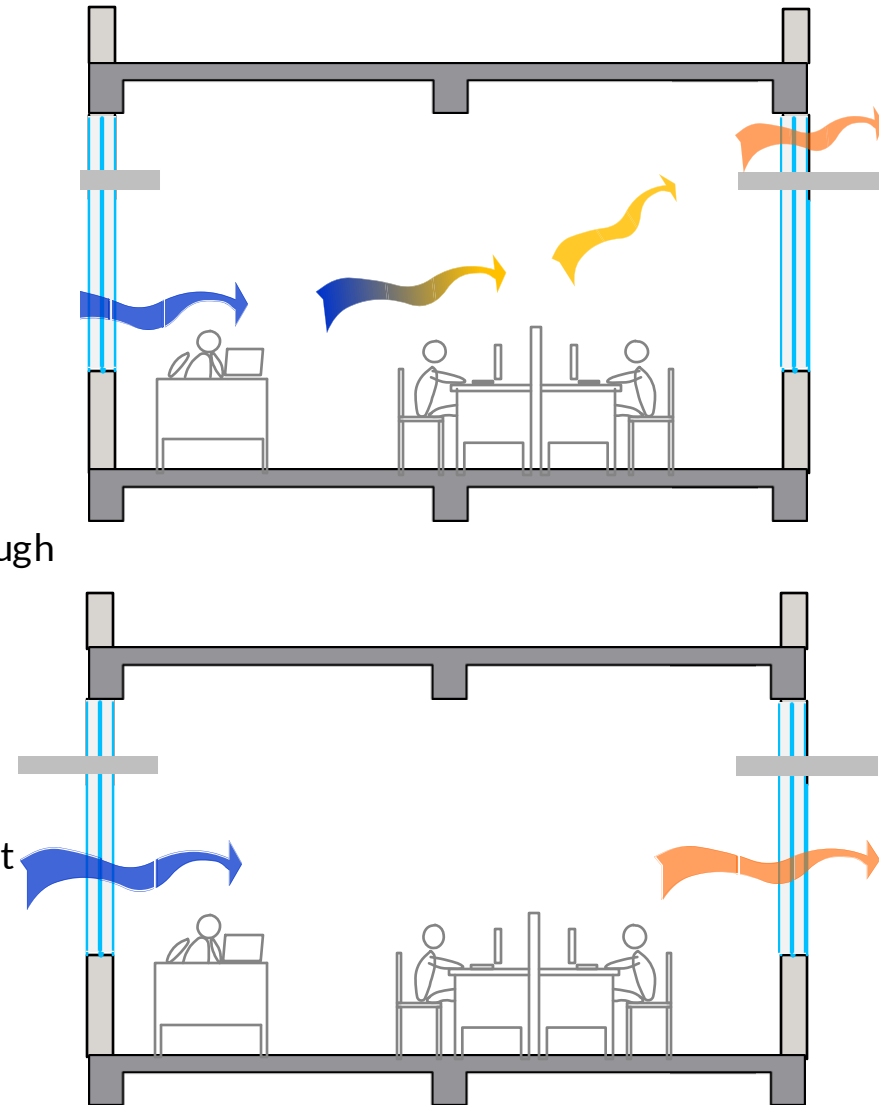

# CROSS VENTILATION

## Do's and don'ts

Windows located diagonally opposite to each other with the windward window near to the upstream, offers better performance than other window arrangements

The placement of window openings can alter air movement inside spaces

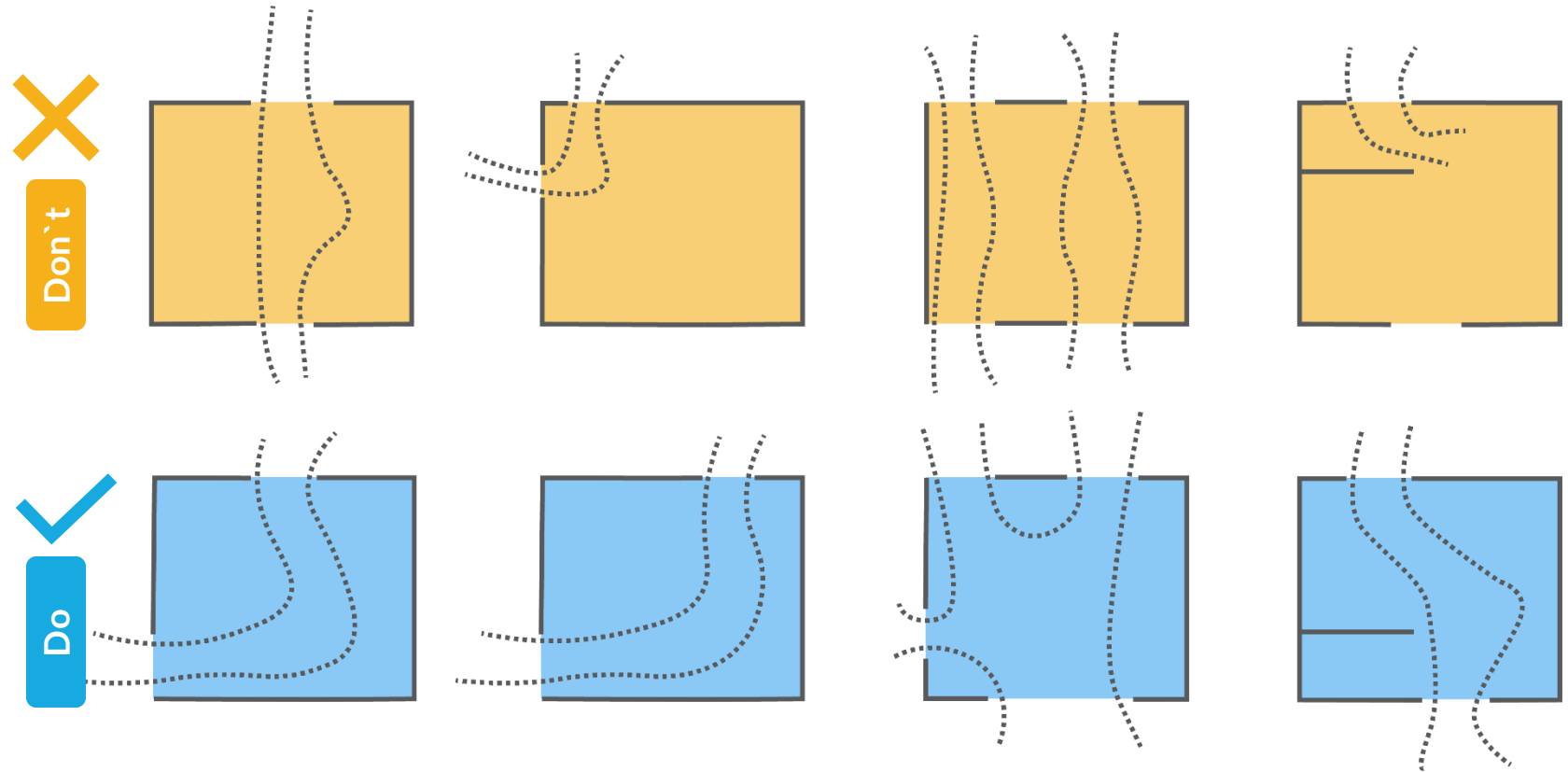

# CROSS VENTILATION

## Do's and don'ts

- The provision of horizontal sashes at an angle of 45° in the appropriate direction helps in promoting indoor air movement
- Sashes projecting outward are more effective than inward

Position of overhangs and louvers can be used to direct the air inside at the required level and area

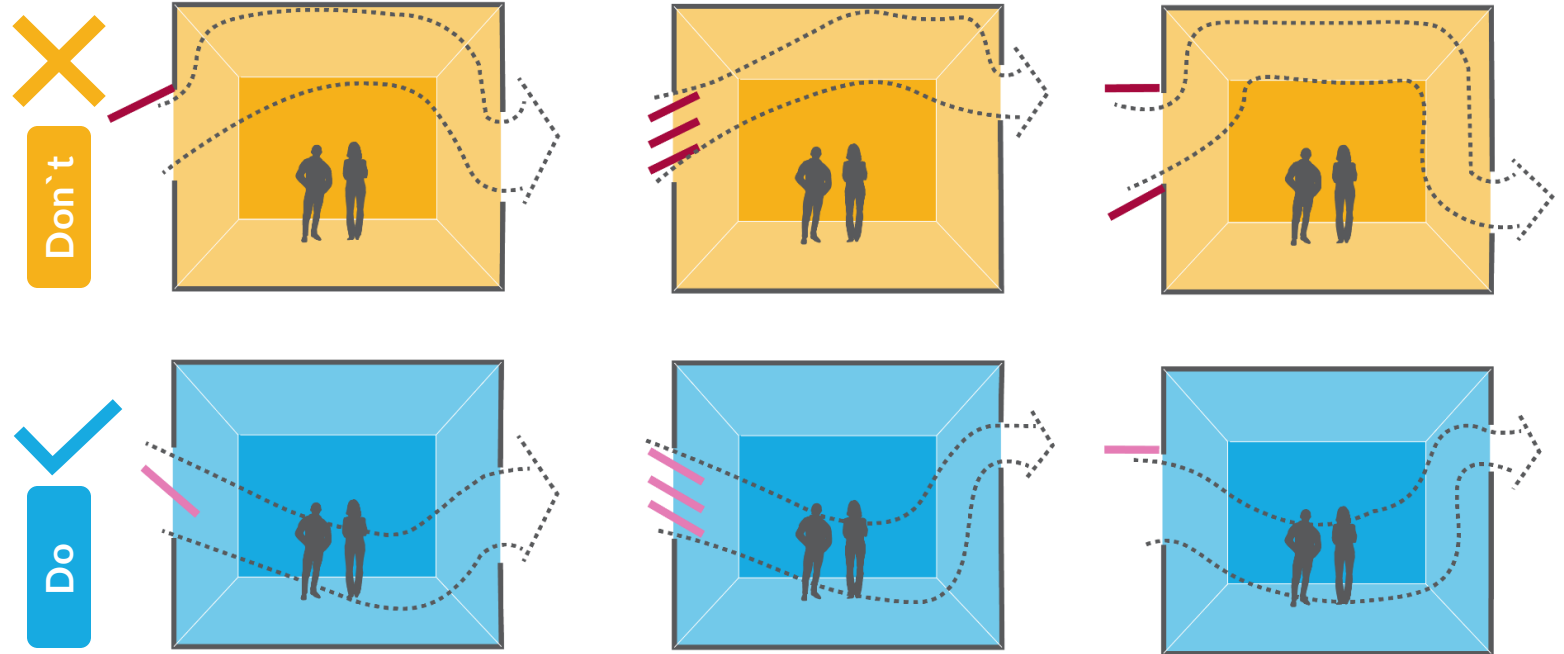

# ONE-SIDED VENTILATION

## Do's and don'ts

Single-sided ventilation is the scenario in which only a single façade of the building is exposed to wind and operable windows are located on a single wall. In such cases, it is preferred to provide at least two windows on the façade

### Provision of two windows on the same façade

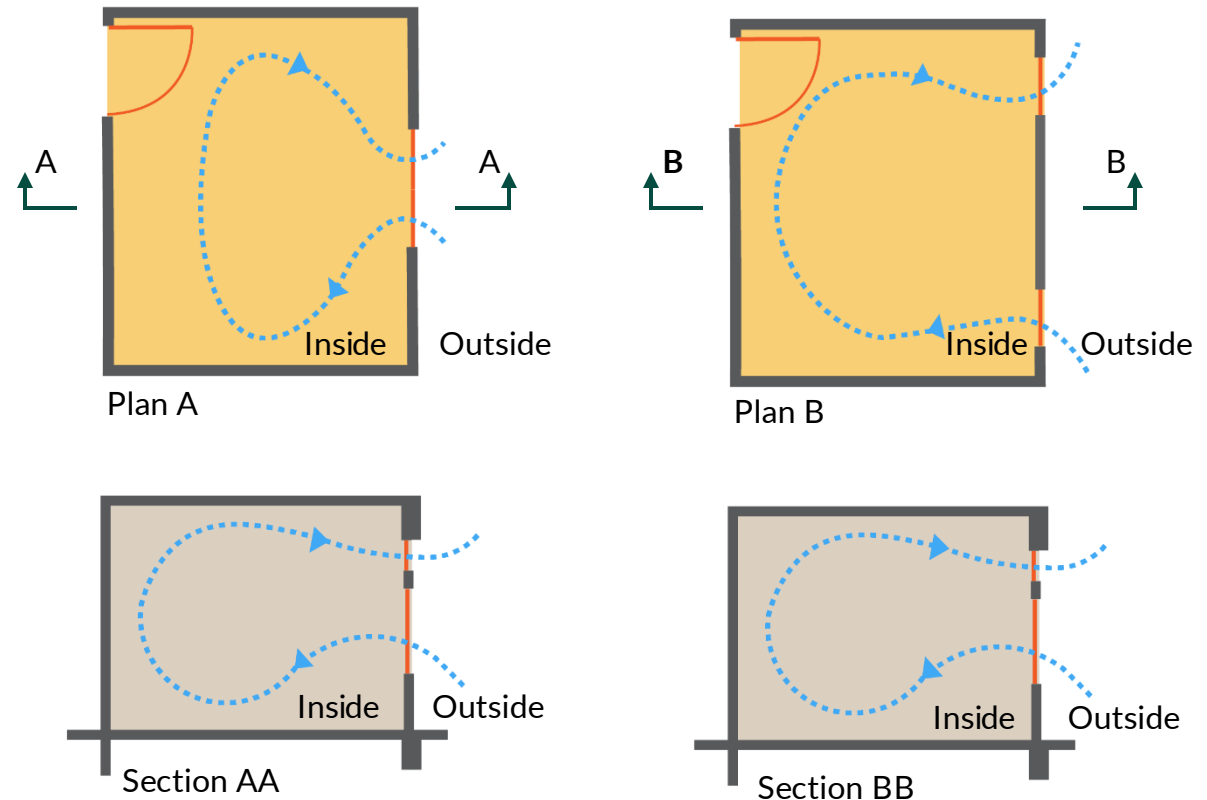

# WINDOW SIZING

## In naturally-ventilated buildings

- Window size can affect both the amount of air and its speed
- For an adequate amount of air, one rule of thumb states that the area of operable windows or louvers should be 20% or more of the floor area, with the area of inlet openings roughly matching the area of outlets
- To increase cooling effectiveness, a smaller inlet can be paired with a larger outlet opening. With this configuration, inlet air can have a higher velocity

Usually a ratio of 1:2.5 or 1:3 between windward side and leeward side is preferred in tropical areas

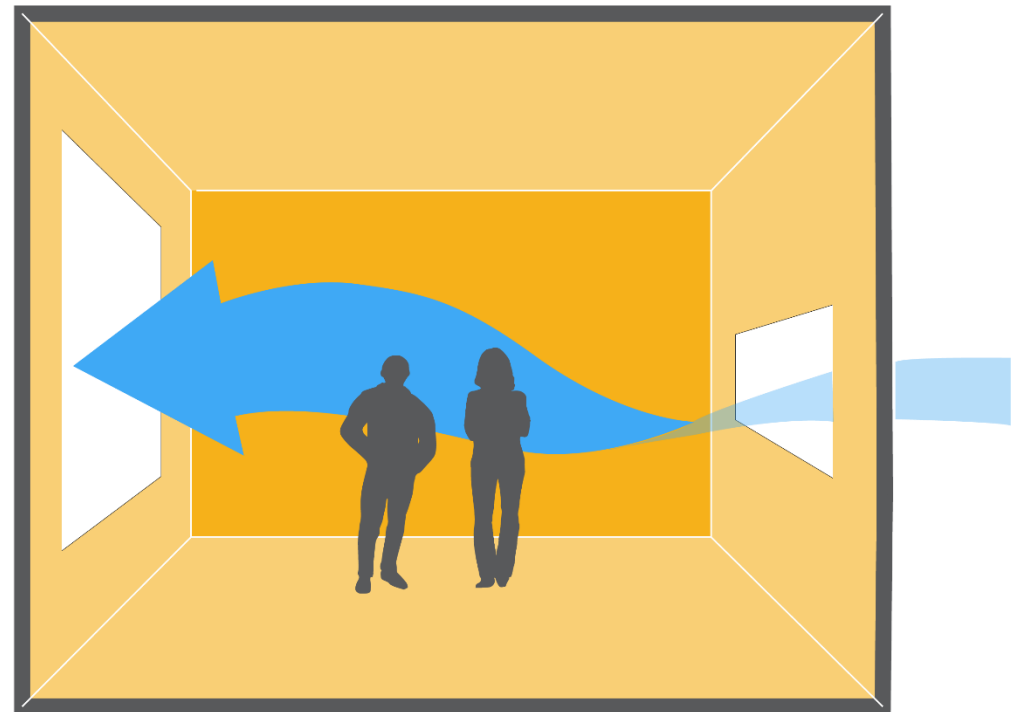

# Solar Shading



# SOLAR SHADING

## North façade

- In the northern hemisphere, north-facing windows receive direct sunlight in summer mornings and evenings
- Vertical fins can shade adequately

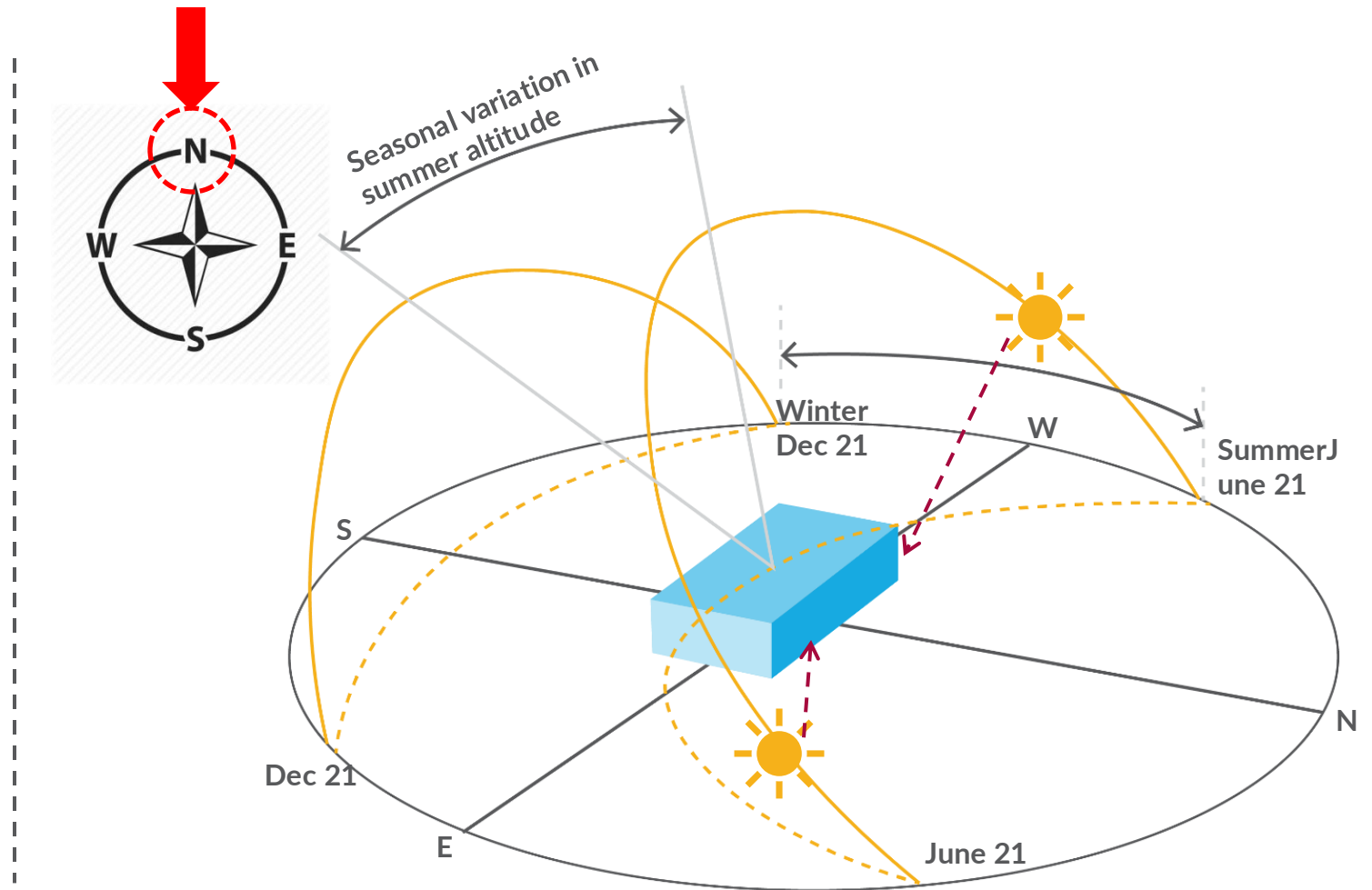

# SOLAR SHADING

## South façade

In the northern hemisphere, horizontal overhangs can effectively cut direct solar radiation on the south façade in summer

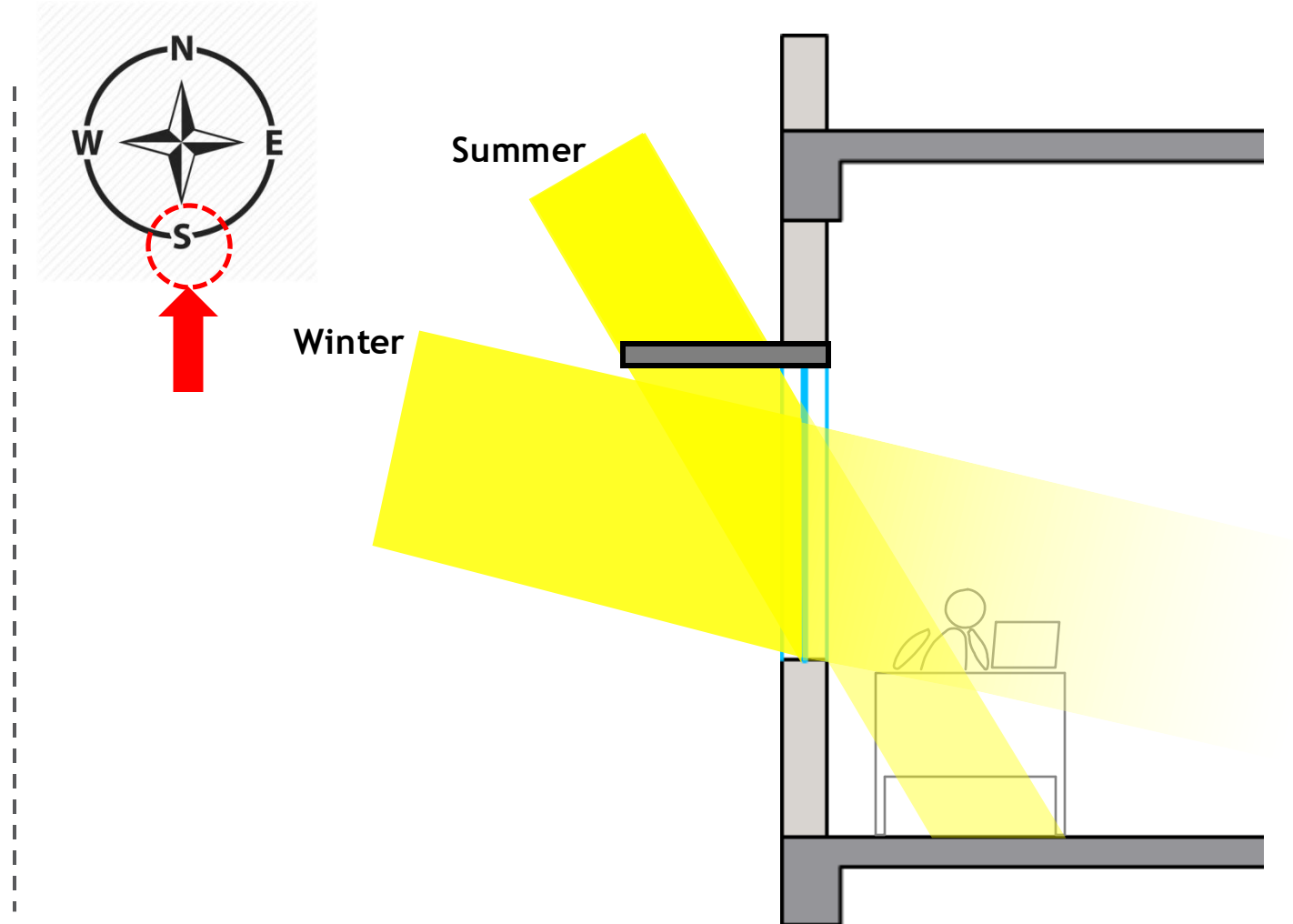

# SOLAR SHADING

Case examples: South façade



**Institute of Rural Research and Development,  
Gurugram, India**



**Infosys, Hyderabad, India**

# SOLAR SHADING

## East and west façades

- Low sun on east and west façades
- Solar azimuth angle also changes
- **Dynamic shading** most effective on east and west façades

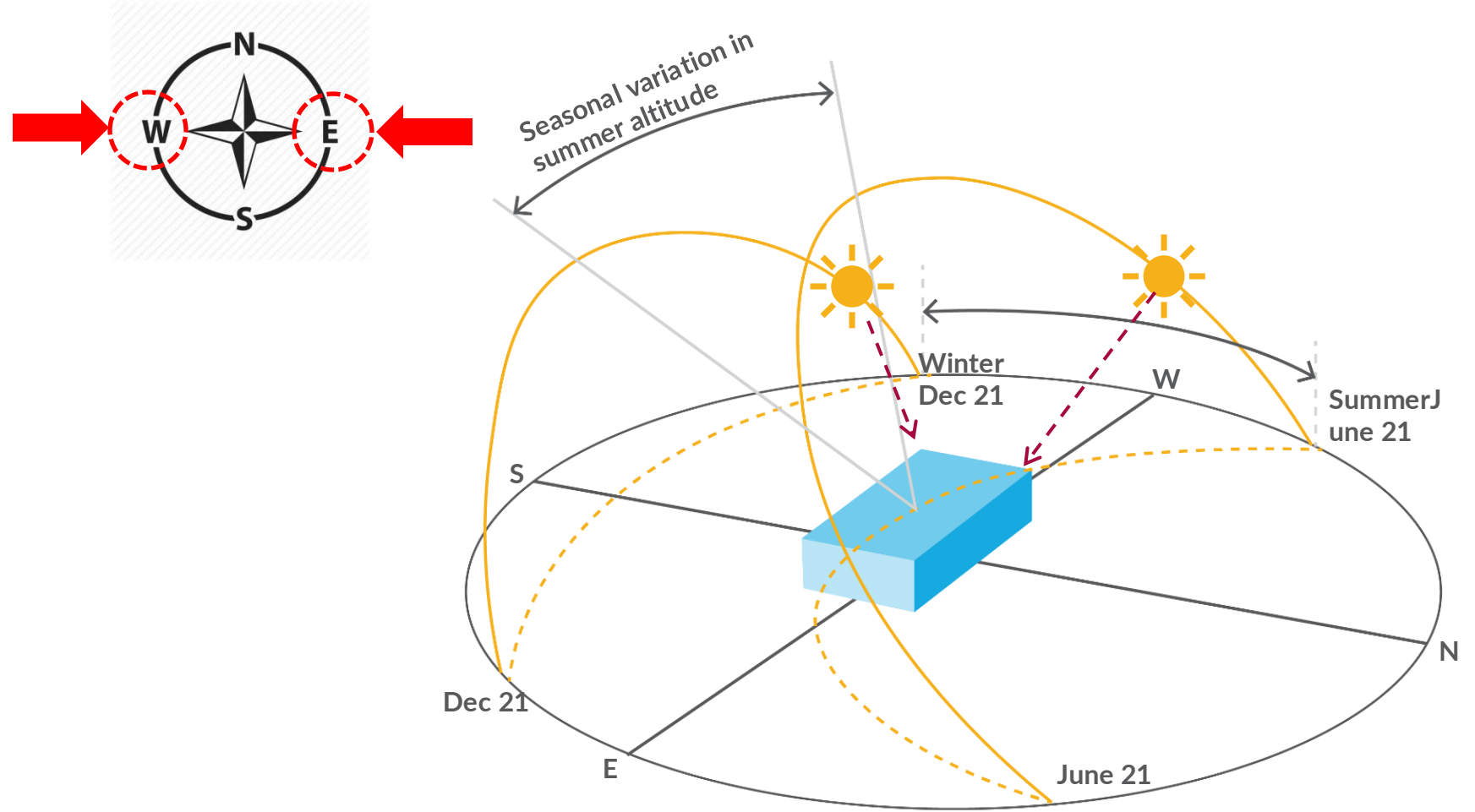

# EXTERNAL MOVABLE SHADING

Case examples: East and west façades



**Rolex Learning Centre, Lausanne**



**Safal Profitaire, Ahmedabad**

# EXTERNAL MOVABLE SHADING

Reduces solar heat gains by 60%–80%

- Performance monitoring of **two identical flats** on the 10<sup>th</sup> and 11<sup>th</sup> floor in Gurugram
- One flat with **external movable shading** and the other with **internal curtains**
- Monitored for both **naturally-ventilated (NV) and air-conditioned (AC)** cases



A difference of **~3.5°C** was observed in peak inside operative temperature in naturally-ventilated case

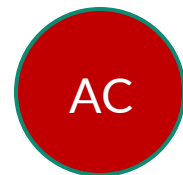

A difference of **~32%** was observed in cumulative cooling demand (thermal) in air-conditioned case

Source: Ministry of Power, Government of India, 2022b

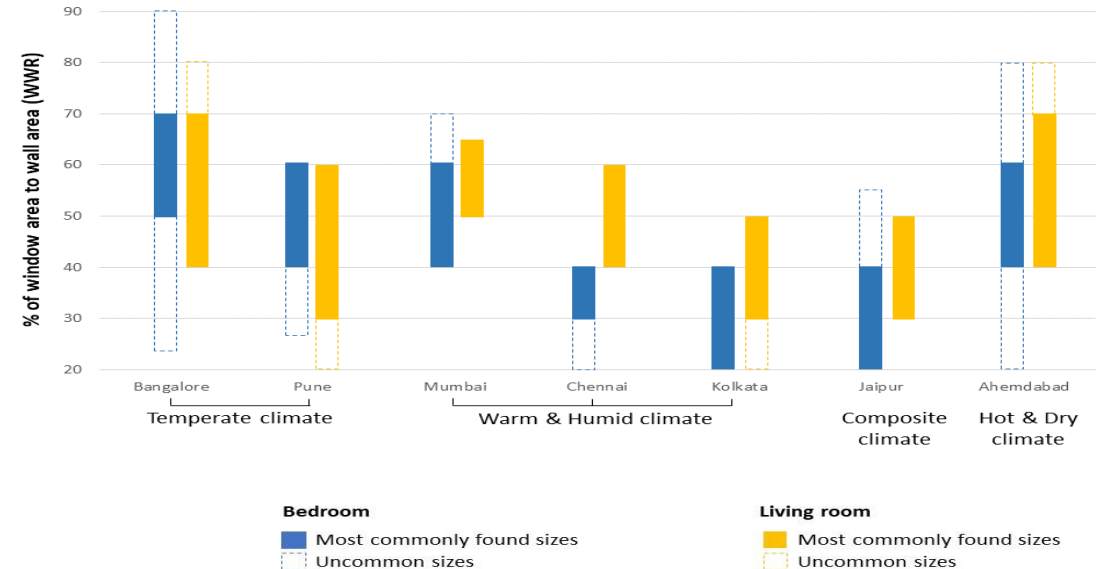

- Trends of **increasing window areas** in residential buildings
- Window-to-wall ratio of 50 buildings spread over 7 cities measured
- Low-income, middle-income and high-income housing covered in study
- **High-income houses showed the largest window sizes across all cities and climate zones**

# Optimizing Building Envelope

Walls and Roofs

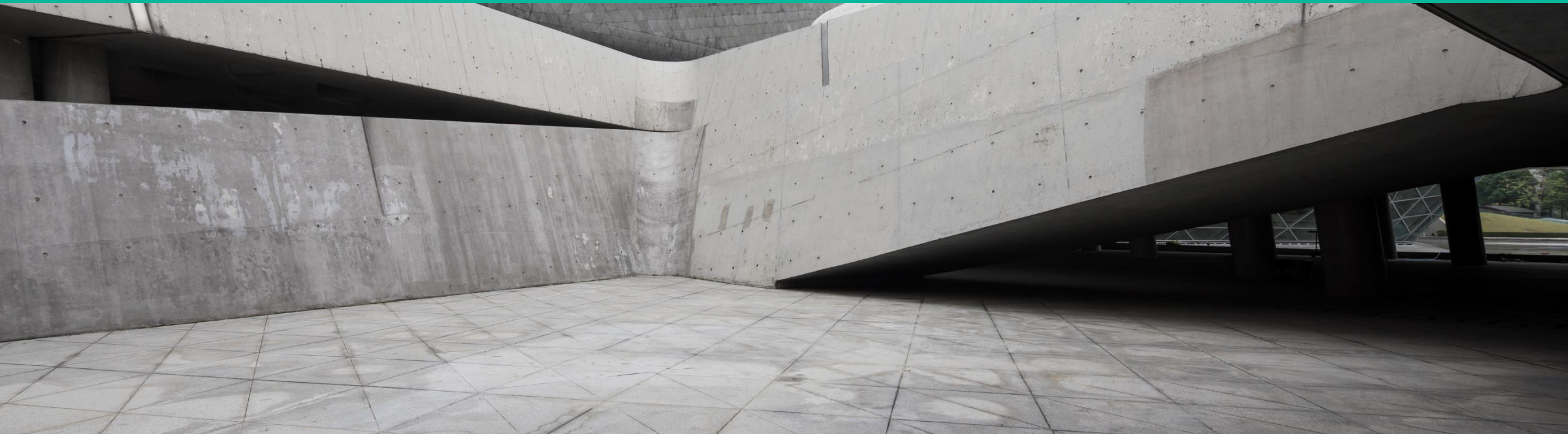

# WALLS AND ROOFS

## Reducing solar heat gains

- Walls with **high thermal mass and low U-value**
- Use of insulation
  - **Roofs** - All climates
  - **Walls** - All climates, excluding warm-humid climates

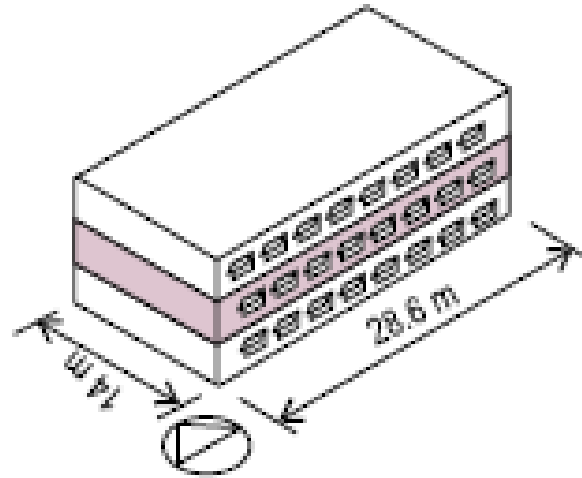

Level: Intermediate floor 6 inch RCC slab with plaster (U-value:  $3.8 \text{ W/m}^2\cdot\text{K}$ )

In case of an intermediate floor, heat gain from window is highest

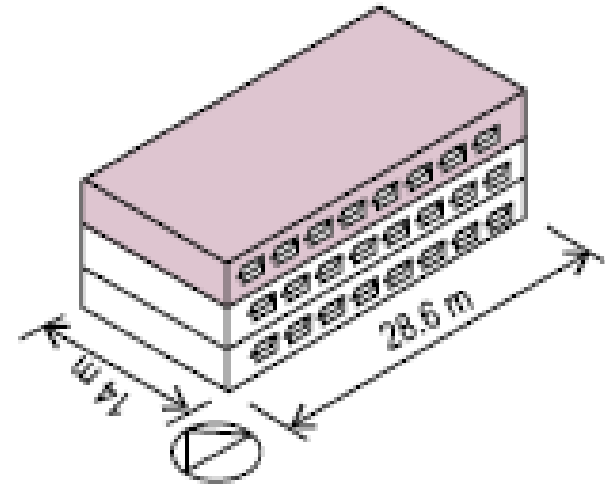







Roof: 150mm RCC slab with plaster (U-value:  $3.8 \text{ W/m}^2\cdot\text{K}$ )

In case of top floor, heat gain from roof is highest

# WALLING MATERIALS

Comparative thermal properties and embodied carbon

Type	U-Value (W/m.K)	Thermal Mass	Embodied Energy
 Solid Fired Clay Brick	Medium (0.4–1.0)	Medium to High	1,616 MJ/m <sup>2</sup>
 Hollow Clay Fired Block	High (0.3)	Low to Medium	814 MJ/m <sup>2</sup>
 Compressed Stabilized Earth Brick	Medium (0.6–1.0)	High	203 MJ/m <sup>2</sup>
 Fly Ash Brick	Medium (0.4–0.9)	Medium to High	466 MJ/m <sup>2</sup>
 Concrete Block	Poor (1.0–1.5)	High	407 MJ/m <sup>2</sup>
 Autoclaved Aerated Concrete Block	High (0.2)	Low to Medium	317 MJ/m <sup>2</sup>

Sources: Bureau of Energy Efficiency, Government of India, 2024; EDGE

# TYPES OF WALLING ASSEMBLIES

## U-values

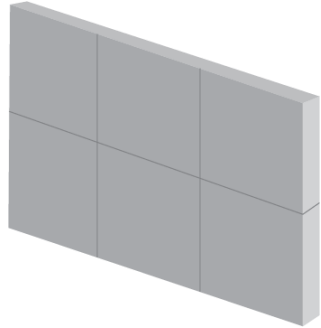

150 mm RCC (no plaster)

U-value  
3.77 W/m<sup>2</sup>.K

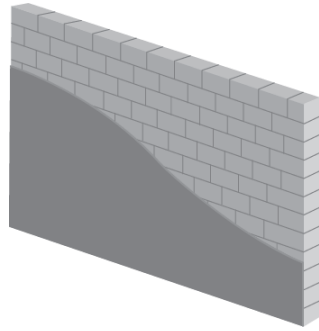

200 mm solid concrete block with 15 mm plaster on both sides

U-value  
2.8 W/m<sup>2</sup>.K

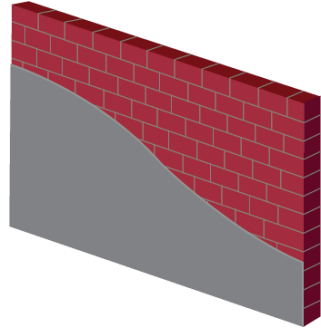

230 mm brick with 15 mm plaster on both sides

U-value  
1.72-2.24 W/m<sup>2</sup>.K

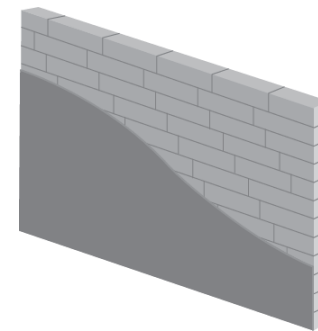

200 mm autoclaved aerated concrete with 15 mm plaster on both sides

U-value  
0.77 W/m<sup>2</sup>.K

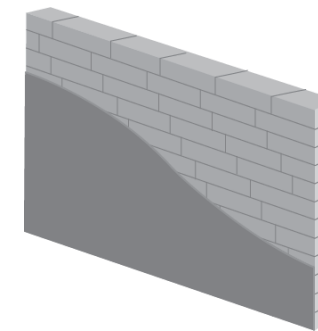

300 mm autoclaved aerated concrete with 15 mm plaster on both sides

U-value  
0.54 W/m<sup>2</sup>.K

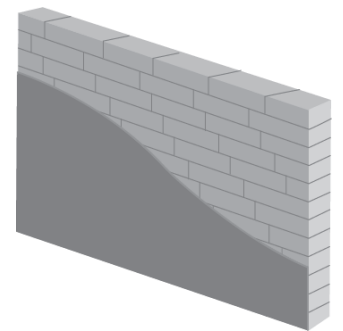

230 mm thick cavity wall of bricks (115 mm outer wall, 75 mm inner wall with 40 mm cavity)

U-value  
0.62 W/m<sup>2</sup>.K

Source: Bureau of Energy Efficiency, Government of India, 2024

# ROOF INSULATION

## Methods of application

Thermal conductivity of common insulation materials usually range from 0.03–0.05 W/m.K which is 1/10<sup>th</sup> to 1/20<sup>th</sup> that of fired clay brick

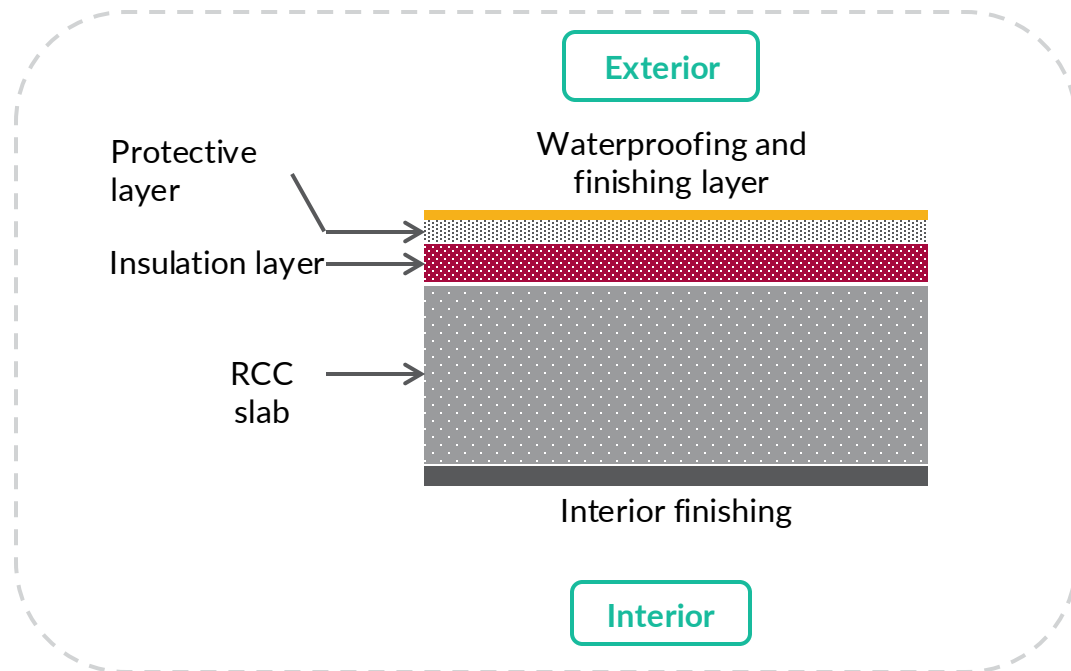

Roof with over-deck insulation

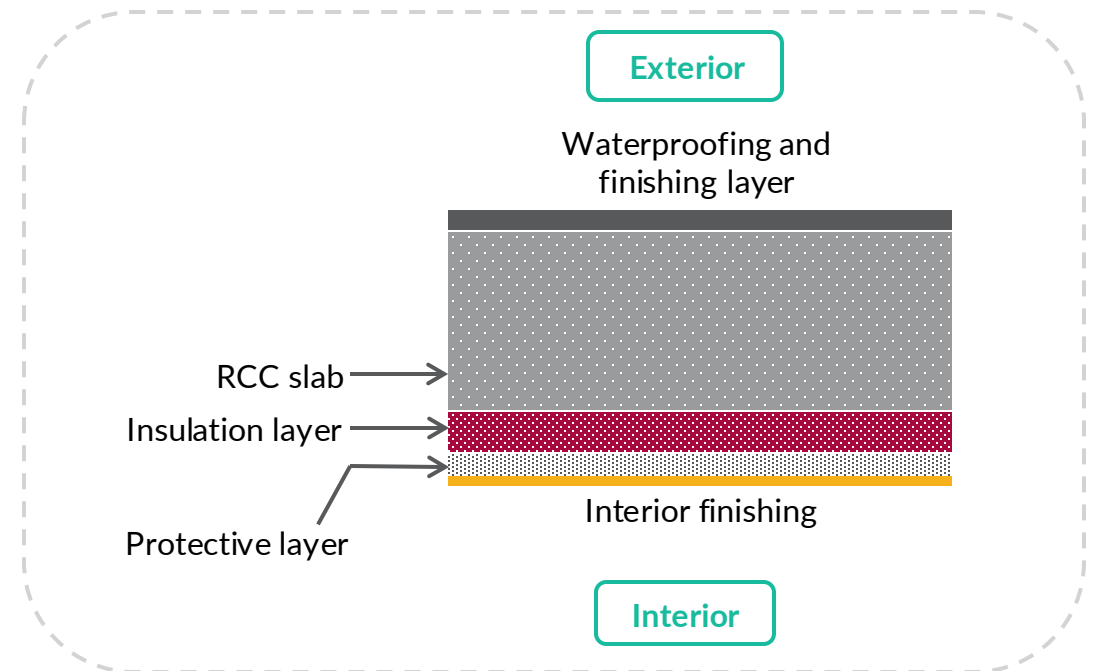

Roof with under-deck insulation

# BUILDING INSULATION

## Rigid insulation materials

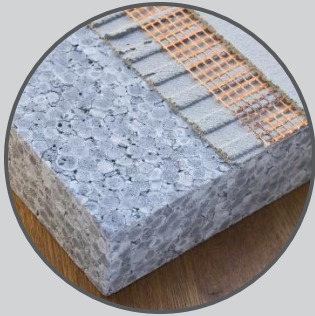

### Expanded Polystyrene (EPS)

- Composed of small beads of polystyrene that are fused together
- Colorless and transparent thermoplastic material

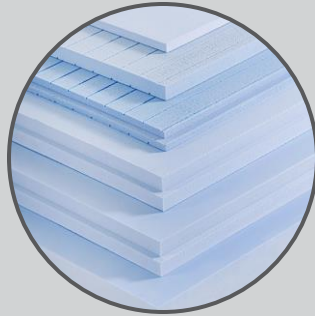

### Extruded Polystyrene (XPS)

- Made of polystyrene, in which molten polystyrene is pressed out of a form into sheets

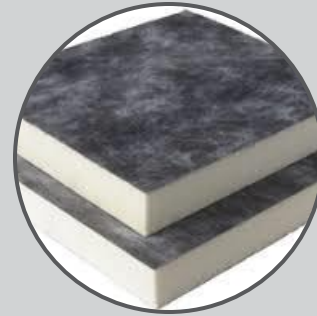

### Polyisocyanurate (PIR)

- Thermosetting type of plastic, closed-cell foam that contains in its cells a hydro-chlorofluorocarbon-free gas of low conductivity
- Available as liquid, sprayed foam and rigid foam board

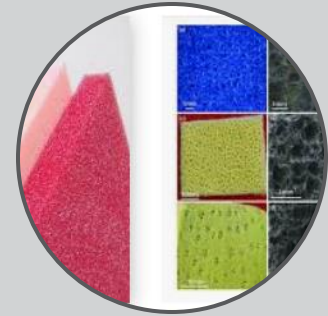

### Polyurethane (PUR)

- Foam insulation material that contains in its cells a gas of low conductivity

# INSULATION MATERIALS

## Fibrous insulation materials



### Glass Wool

- Made from extremely fine fibers of glass
- Arranged into a texture similar to wool by using a binder
- Small air pockets between the glass, which ensures high thermal insulation
- Available in three different forms – blanket (batts and rolls), loose-fill and rigid boards



### Mineral Wool

- Rock wool, a synthetic material consisting of natural minerals like basalt or diabase
- Slag wool, a synthetic material from blast furnace slag (the scum that forms on the surface of molten metal)



# INSULATION MATERIALS

## Natural organic materials



### Hemp Insulation

- Made from hemp wool
- Hemp wool is strong and woody fibers that are derived from the hemp plant



### Cellulose Insulation

- Plant fiber used in wall and roof for insulation purposes
- Modern cellulose insulation is made from either ground recycled paper or recycled denim



### Straw Insulation

- Straw bales are made from agro-waste. Once the edible part of the grain has been harvested (such as wheat or rice), the remaining waste is compressed to make insulation panels

# COOL ROOF

## Reflective external roof surfaces

- High Solar Reflectance Index finishes on roofs
- Use of **insulation in all climates** (preferably over-deck)

Cool roofs reflect sunlight back to the atmosphere to a greater extent than regular roof surfaces

When solar radiation falls on a roof, the roof surface performs three functions:

- Reflects a part of the incident solar radiation back into the atmosphere
- Conducts a part of the heat through itself into the buildings
- Transfers a part of the heat to the ambient air (external and internal)

Cool roofs emit a part of the absorbed heat to internal surfaces and the rest back to the sky

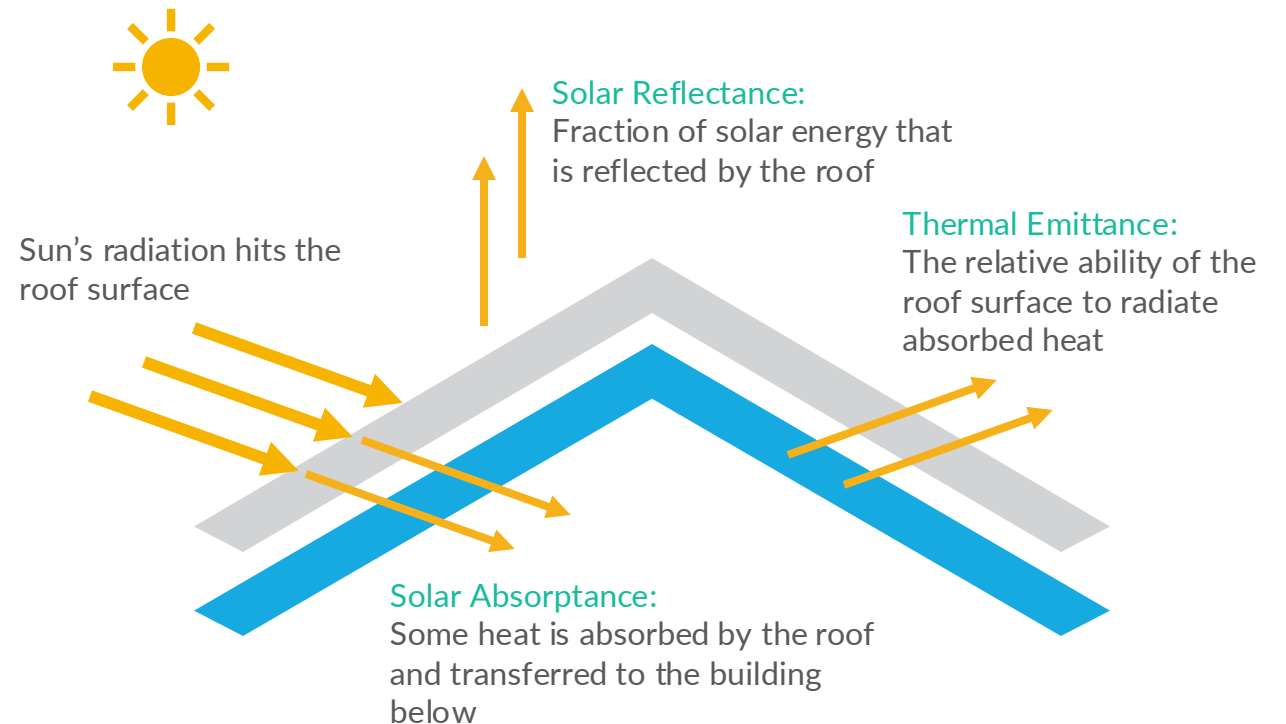

# COOL ROOF

Case study: Affordable Housing Project, Andhra Pradesh, India

Comparative performance monitoring to monitor the impact of cool roofs in Andhra Pradesh. Total 12 houses in 3 locations were monitored – half of the houses with cool roof and other half without the cool roof



Reduction of around 6°C–9°C in under-deck temperatures was found with cool roof application (without any false ceiling)

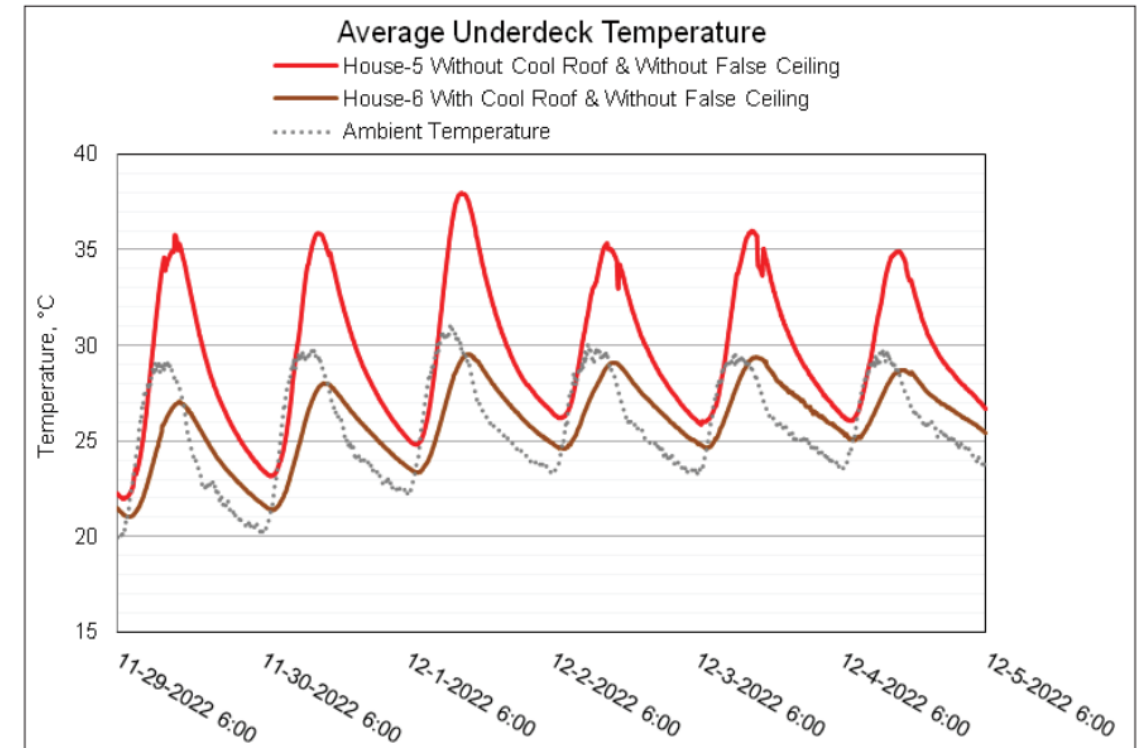

# Building Envelope Features

Recommendations for Different Climates



# HOT AND DRY CLIMATE

## Key recommendations

OBJECTIVES	PHYSICAL MANIFESTATION
<b>1) Resist heat gain</b>	
• Decrease exposed surface area	• Orientation and shape of building
• Increase thermal resistance	• Insulation of building envelope
• Increase thermal capacity (time lag)	• Massive structure
• Increase buffer spaces	• Air locks, lobbies, balconies, verandas
• Decrease air exchange rate (ventilation during daytime)	• Weather stripping and scheduling air changes
• Increase shading	• External surfaces protected by overhangs, fins and trees
• Increase surface reflectivity	• Pale color, glazed china mosaic tiles, etc.
<b>2) Promote heat loss</b>	
• Ventilation of appliances	• Provide windows and exhausts
• Increase air exchange rate (ventilation during nighttime)	• Courtyards, wind towers, arrangement of openings
• Increase humidity level	• Trees, water ponds, evaporative cooling

Source: Nayak and Prajapati, 2006

# WARM AND HUMID CLIMATE

## Key recommendations

OBJECTIVES	PHYSICAL MANIFESTATION
<b>1) Resist heat gain</b>	
<ul style="list-style-type: none"> <li>• Decrease exposed surface area</li> <li>• Increase thermal resistance</li> <li>• Increase buffer spaces</li> <li>• Increase shading</li> <li>• Increase surface reflectivity</li> </ul>	<ul style="list-style-type: none"> <li>• Orientation and shape of building</li> <li>• Roof and wall insulation. Reflective surface of roof</li> <li>• Balconies and verandas</li> <li>• Walls and glass surfaces protected by overhangs, fins and trees</li> <li>• Pale color, glazed china mosaic tiles, etc.</li> </ul>
<b>2) Promote heat loss</b>	
<ul style="list-style-type: none"> <li>• Ventilation of appliances</li> <li>• Increase air exchange rate (ventilation throughout the day)</li> </ul>	<ul style="list-style-type: none"> <li>• Provide windows and exhausts</li> <li>• Ventilated roof construction, courtyards, wind towers, and arrangement of openings</li> </ul>

Source: Nayak and Prajapati, 2006

# TEMPERATE CLIMATE

## Key recommendations

OBJECTIVES	PHYSICAL MANIFESTATION
<b>1) Resist heat gain</b>	
<ul style="list-style-type: none"> <li>• Decrease exposed surface area</li> <li>• Increase thermal resistance</li> <li>• Increase shading</li> <li>• Increase surface reflectivity</li> </ul>	<ul style="list-style-type: none"> <li>• Orientation and shape of building</li> <li>• Roof insulation and east and west wall insulation</li> <li>• East and west walls and glass surfaces protected by overhangs, fins and trees</li> <li>• Pale color, glazed china mosaic tiles, etc.</li> </ul>
<b>2) Promote heat loss</b>	
<ul style="list-style-type: none"> <li>• Ventilation of appliances</li> <li>• Increase air exchange rate (ventilation)</li> </ul>	<ul style="list-style-type: none"> <li>• Provide windows and exhausts</li> <li>• Courtyards and arrangement of openings</li> </ul>

Source: Nayak and Prajapati, 2006

# COMPOSITE CLIMATE

## Key recommendations

OBJECTIVES	PHYSICAL MANIFESTATION
<b>1) Resist heat gain in summer and resist heat loss in winter</b>	
• Decrease exposed surface area	• Orientation and shape of building. Use of trees as wind barriers
• Increase thermal resistance	• Roof and wall insulation
• Increase thermal capacity (time lag)	• Thicker walls
• Increase buffer spaces	• Air locks and balconies
• Decrease air exchange rate	• Weather stripping
• Increase shading	• Walls and glass surfaces protected by overhangs, fins and trees
• Increase surface reflectivity	• Pale color, glazed china mosaic tiles, etc.
<b>2) Promote heat loss in summer and monsoon</b>	
• Ventilation of appliances	• Provide exhausts
• Increase air exchange rate (ventilation)	• Courtyards, wind towers, arrangement of openings
• Increase humidity level in dry summer	• Trees and water ponds for evaporative cooling

Source: Nayak and Prajapati, 2006

# COLD CLIMATE

## Key recommendations

OBJECTIVES	PHYSICAL MANIFESTATION
<b>1) Resist heat gain in summer and heat loss in winter</b>	
• Decreased exposed surface area	• Orientation and shape of building. Use of trees as wind barriers
• Increase thermal resistance	• Roof insulation, wall insulation and double glazing
• Increase thermal capacity (time lag)	• Thicker walls
• Increase buffer spaces	• Air locks and lobbies
• Decrease air exchange rate	• Weather stripping
• Increase air absorptivity	• Darker colors
<b>2) Promote heat loss in summer and monsoon</b>	
• Reduce shading	• Walls and glass
• Utilize heat from appliances	
• Trapping heat	• Sun walls, green houses, Trombe walls, etc.

Source: Nayak and Prajapati, 2006

# Thank you!

For more information, visit us at <https://ALCBT.GGGI.ORG>  
or scan the QR code below



## IKI Independent Complaint Mechanism

Any person who believes they may be harmed by an IKI project or who wish to report corruption or the misuse of funds, can lodge a complaint to the IKI Independent Complaint Mechanism at [IKI-complaints@z-u-g.org](mailto:IKI-complaints@z-u-g.org). The IKI complaint mechanism has a panel of independent experts who will investigate the complaint. In the course of the investigation, we will consult with the complainant so as to avoid unnecessary risks for the complainant. More information can be found at <https://www.international-climate-initiative.com/en/about-iki/values-responsibility/independent-complaint-mechanism/>.

 [www.gggi.org](http://www.gggi.org)

 [@gggi\\_hq](https://twitter.com/gggi_hq)

 [@GGGIHQ](https://www.instagram.com/gggi_hq)

 [@GGGIHQ](https://www.facebook.com/gggi_hq)

 [@gggi\\_hq](https://www.linkedin.com/company/gggi_hq)

 [@GGGIMedia](https://www.youtube.com/channel/UCGgI-Media)



Supported by:



on the basis of a decision  
by the German Bundestag

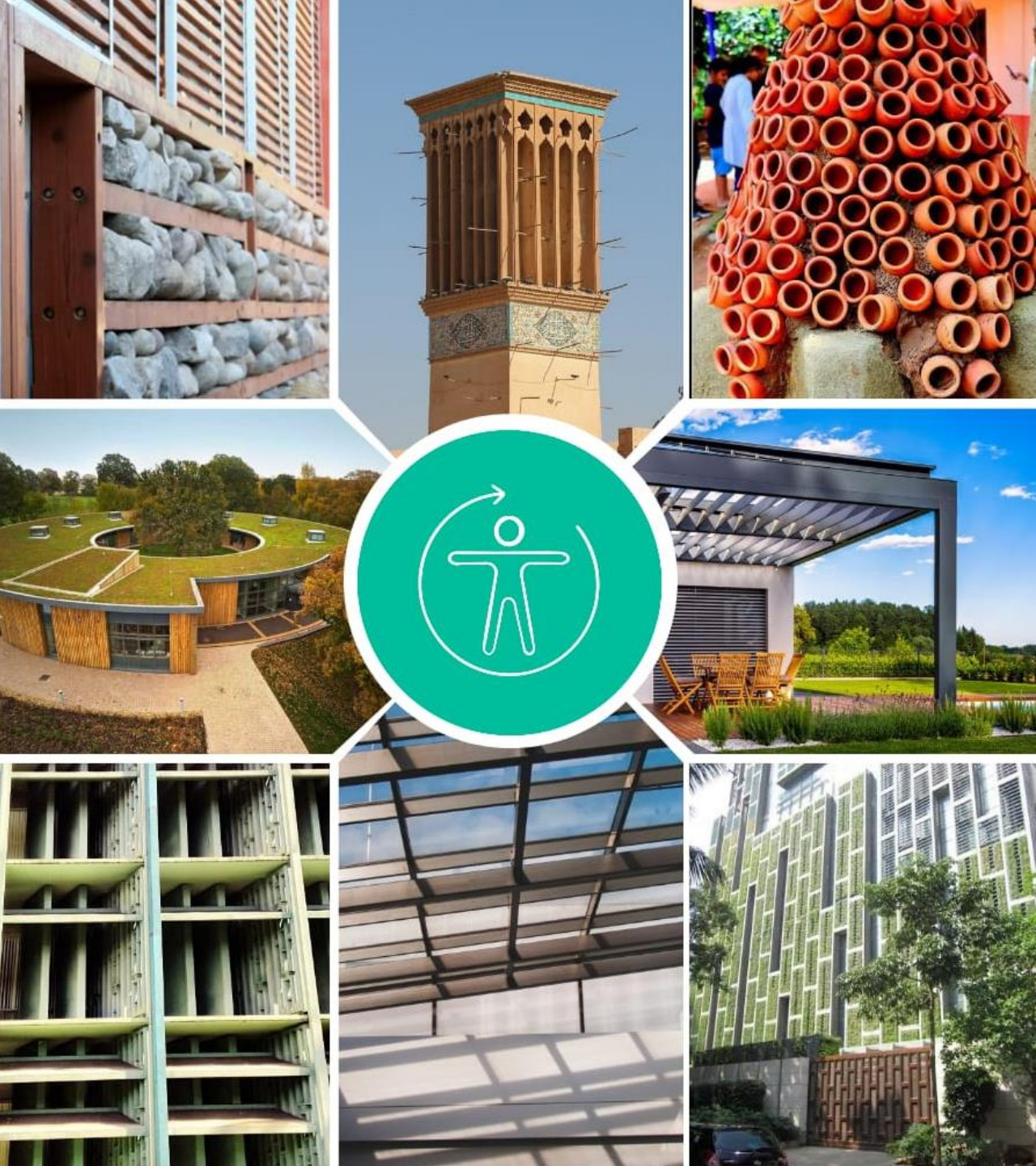

## 2.3 Adaptive Thermal Comfort Design Strategies

November 2024

# WHAT WILL YOU LEARN?

Understand human comfort perceptions

01

Factors affecting human thermal comfort

02

Understand dynamics of heat generation and dissipation from human body

03

The importance of optimal air movement in rooms

04

ASHRAE Standards for adaptive thermal comfort

05

Models for adaptive thermal comfort

06

Potential solutions

07



Image source: <https://www.firstinarchitecture.co.uk/internal-environment-thermal-air-sound-and-light/>

# Human Comfort in Buildings

## Indoor Environment



# INDOOR ENVIRONMENT QUALITY

For human comfort

Human comfort within buildings can be categorized into four comfort parameters:

- i. Thermal
- ii. Visual
- iii. Acoustical
- iv. Indoor air quality

Each parameter can gradually impact **human health**, if not maintained to prescribed limits

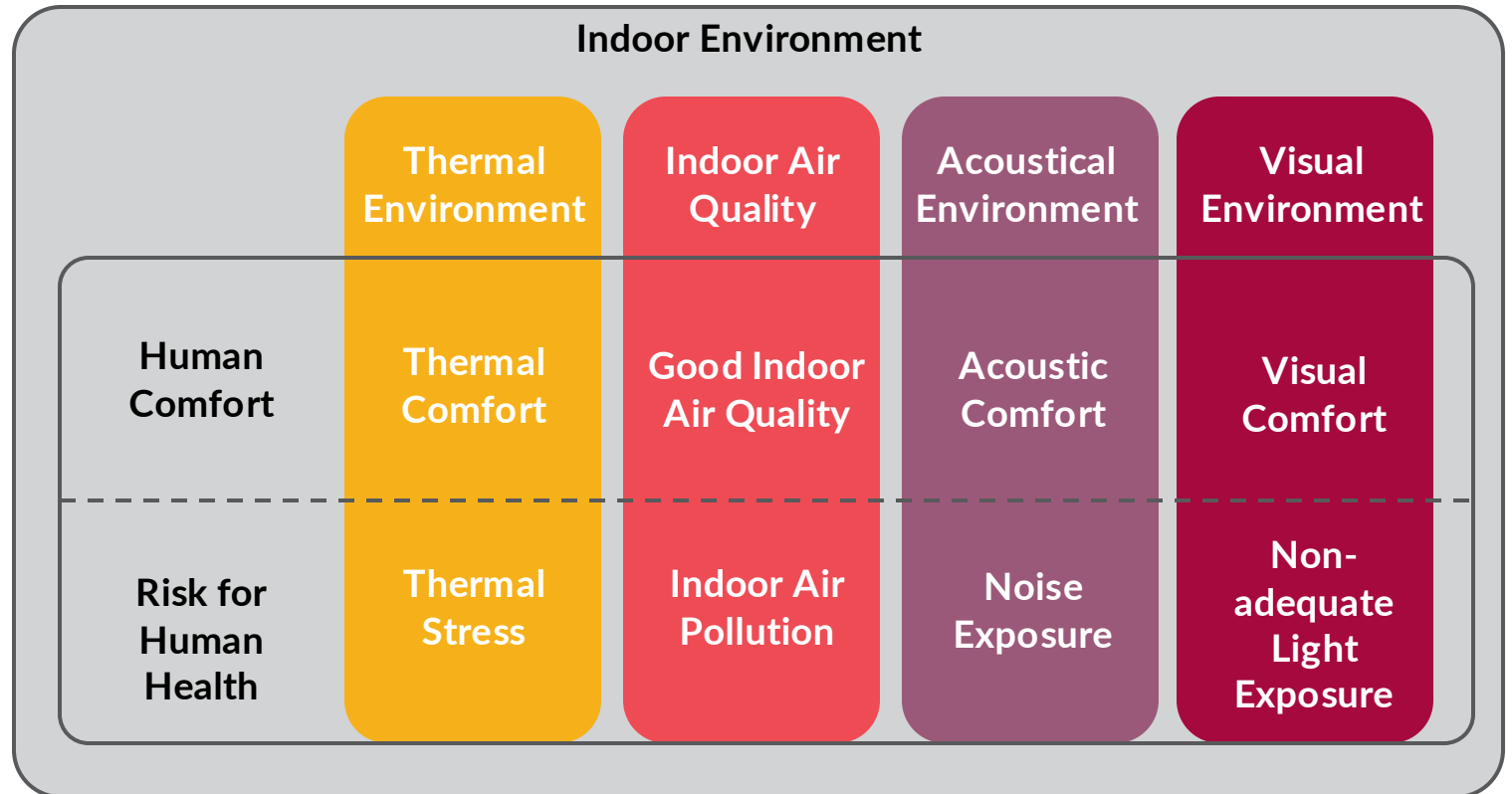

Source: Fantozzi and Rocca, 2020

# VISUAL COMFORT

## Indoor environment

Sharp contrast or major change in light levels can **cause stress and fatigue**, as the human eye then has to constantly adjust to varying lighting levels

Both **too much and too little light** can be a cause of visual discomfort

**Factors determining healthy visual environment include:**

- Access to the outside view
- Adequate daylight without glare
- Uniformly distributed light within the space
- Adequate task lighting



AS OUR LIVING HABITS CONTINUE TO CHANGE SO  
WILL OUR LIGHTING NEEDS AND WHAT WE CONSIDER  
TO BE VISUALLY COMFORTABLE.

# ACOUSTICAL COMFORT

## Indoor environment

Four types of noise, emanating from the following sources, are usually experienced in buildings:

- i. Exterior
- ii. Interior
- iii. Impact
- iv. Equipment

These noises are transmitted through the building fabric.

The nature of the sounds and its perception by the human ear depends on its **reverberation and absorption within the building**



WHEN DESIGNING FOR ACOUSTIC COMFORT, IT IS KEY TO UNDERSTAND OCCUPANT NEEDS: ACTIVITIES TO BE PERFORMED, TYPES OF NOISE TO BE MANAGED, CONSTRUCTION SYSTEM AND MATERIALS.

# AIR QUALITY

## Indoor environment

### Health effects of poor indoor air quality:

- i. Respiratory problems
- ii. Headaches and fatigue
- iii. Allergic reactions
- iv. Long-term health risks

### Common indoor air pollutants

- i. Dust and particulate matter
- ii. Mold and mildew
- iii. Carbon monoxide
- iv. Volatile organic compounds (VOCs)
- v. Radon

## Indoor Air Quality 5 Things You Need to Know



Air pollution is **one of the top 5 factors** causing chronic disease according to the World Health Organization [along with unhealthy diet, physical inactivity, tobacco use, harmful alcohol use]<sup>1</sup>



**Almost 90% of our time** is spent indoors and almost **70% in our homes** [indoors: 87%, at home: 69%]<sup>2</sup>



We consume **nearly 8 times** as much air by volume as food and **4 times** as much air as water. [air: 31 lbs., water 8 lbs., food 4 lbs.]<sup>3</sup>



Indoor air often **contains 2x-5x as much pollution** as is typical in outdoor air, and as much as 100x.<sup>4</sup>



High-performance homes constructed today **let in significantly less fresh air** than those in older, less efficient homes [about 1/4 the natural infiltration].<sup>5</sup>

<sup>1</sup> World Health Organization, Chronic diseases and their common risk factors, 2005

<sup>2</sup> Lawrence Berkeley National Laboratory, The National Human Activity Pattern Survey (NHAPS), 2001

<sup>3</sup> Sam Rashkin, Housing 2.0, 2021

<sup>4</sup> U.S. Environmental Protection Agency (EPA), The total exposure assessment methodology (TEAM) study: Summary and analysis, 1987

<sup>5</sup> Sam Rashkin, Housing 2.0, 2021

# Thermal Comfort

Adaptive Thermal Comfort



# THERMAL COMFORT

And discomfort!!!



**One person's comfort is another's discomfort**

- The complaint of a person suffering warm, humid room condition may be legitimate
- But often, it is people in centrally air-conditioned rooms who complain of poor or excessive cooling

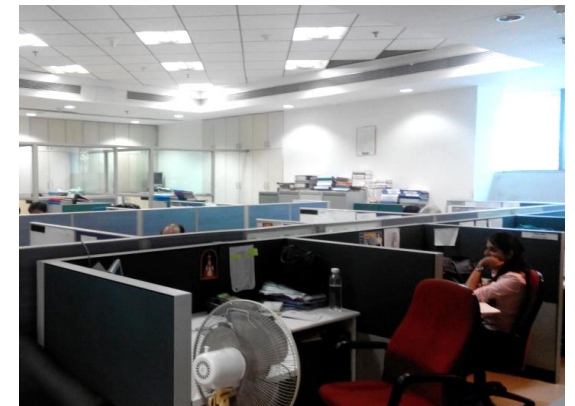
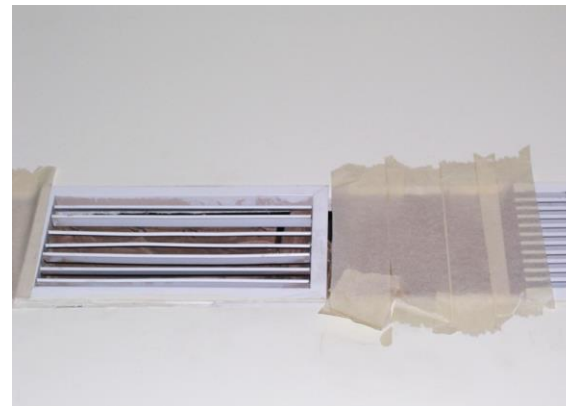

Cases of partially-sealed air supply duct outlets, installation of pedestal fans in air-conditioned spaces, and installation of split air conditioners in centrally air-conditioned rooms

*Image source: SM Solutions*

# THERMAL COMFORT

## Definition and influencing factors

Thermal comfort:

A state of mind that expresses satisfaction with the thermal surroundings

### Influencing factors

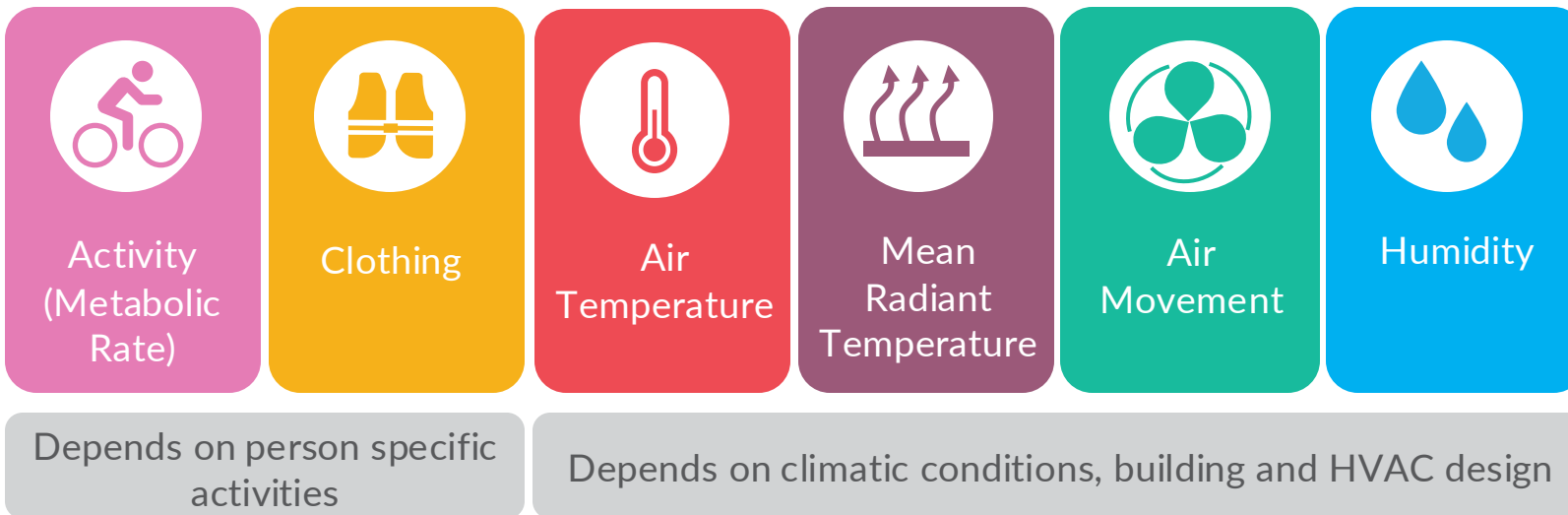

Source: American Society of Heating, Refrigerating and Air-Conditioning Engineers

Image source: <https://www.freepik.com/free-photo/1>

# THERMAL COMFORT

## Facts

Static position  
~105W



Physical activity  
~400W



We feel comfortable when metabolic heat generated by the human body is dissipated at the same rate as it is produced

The human body needs to be maintained at  $36^{\circ}\text{C} \pm 0.5^{\circ}\text{C}$  regardless of prevailing ambient conditions

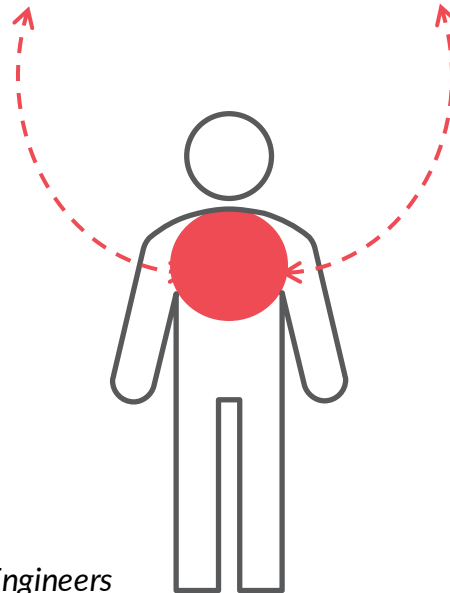

Acceptable air velocity range  
 $0.15\text{m/s} - 0.50\text{m/s}$   
(at  $23^{\circ}\text{C} - 26^{\circ}\text{C}$ )

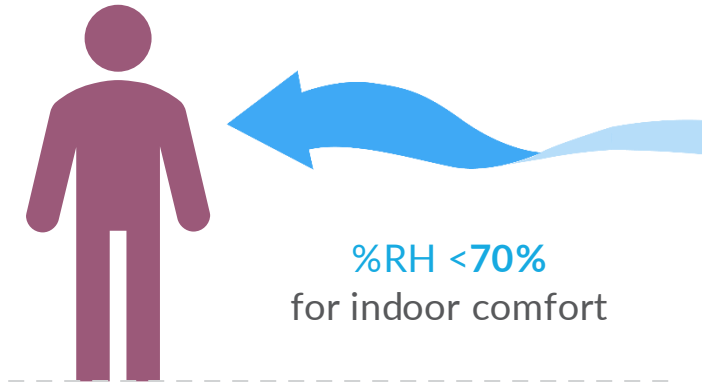

$\%RH < 70\%$   
for indoor comfort

Air movement is essential for comfort as it enhances heat transfer between air and the human body and accelerates cooling of the human body

Source: American Society of Heating, Refrigerating and Air-Conditioning Engineers

# COOLING OF HUMAN BODY

Radiation heat transfer dominates

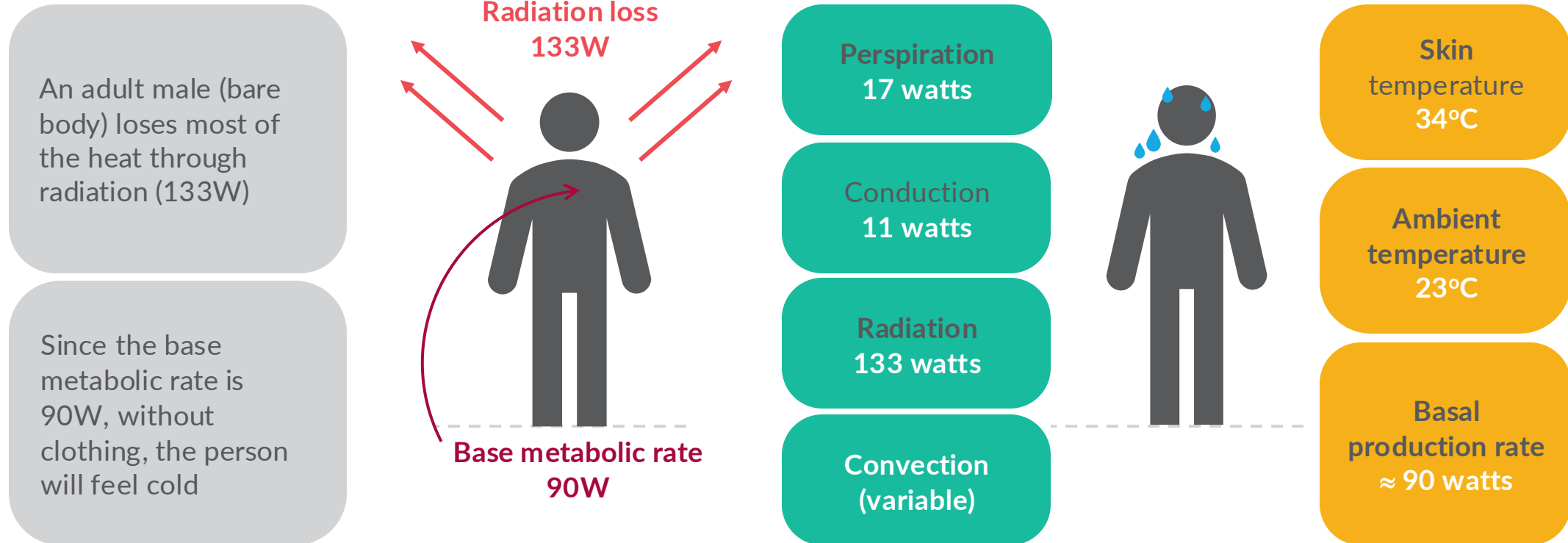

Source: BEEP Training Modules on Radiant Cooling

# HUMAN COMFORT

## Human body heat balance

The body's heat balance can be expressed as:

$$M \pm R \pm C_v \pm C_d - E = \Delta S \text{ (W)}$$

M = metabolic rate

R = net radiation

C<sub>v</sub> = convection

C<sub>d</sub> = conduction

E = evaporation heat loss

ΔS = change in heat stored

- If ΔS is positive, the body temperature increases; if negative, it decreases
- The heat dissipation rate depends on environmental factors, but the body is not purely passive, it is *homoeothermic*

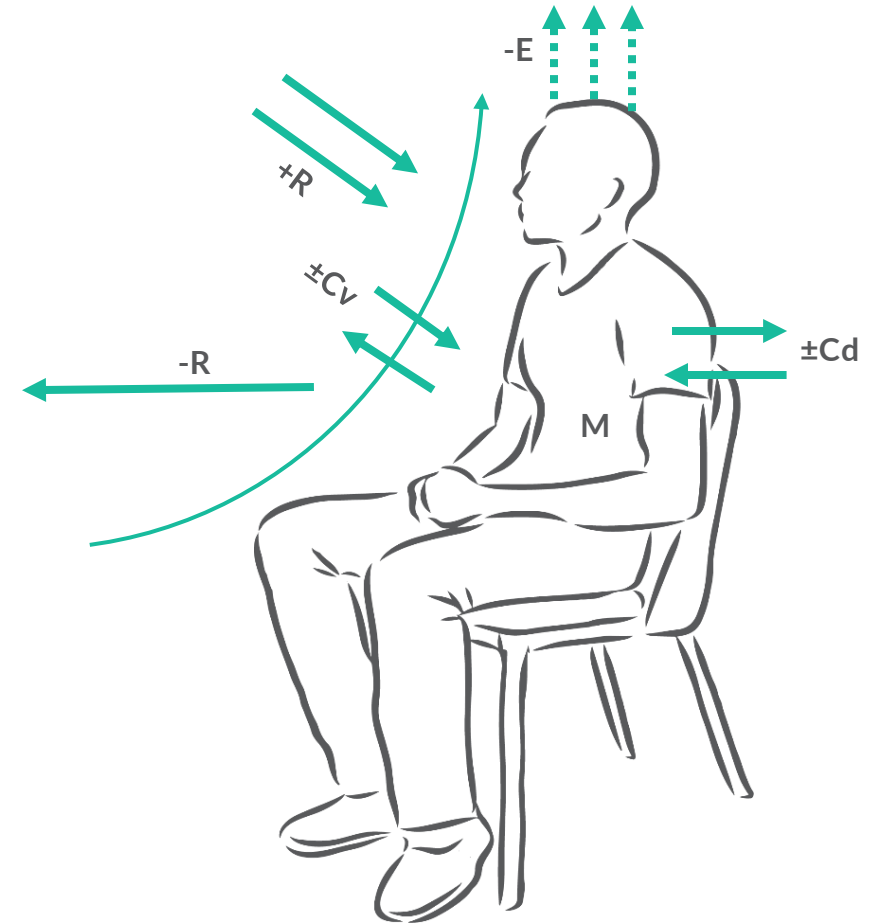

# BUILDING ENVELOPE

Its role in heat transfer

Building envelope design is the key to energy efficient building

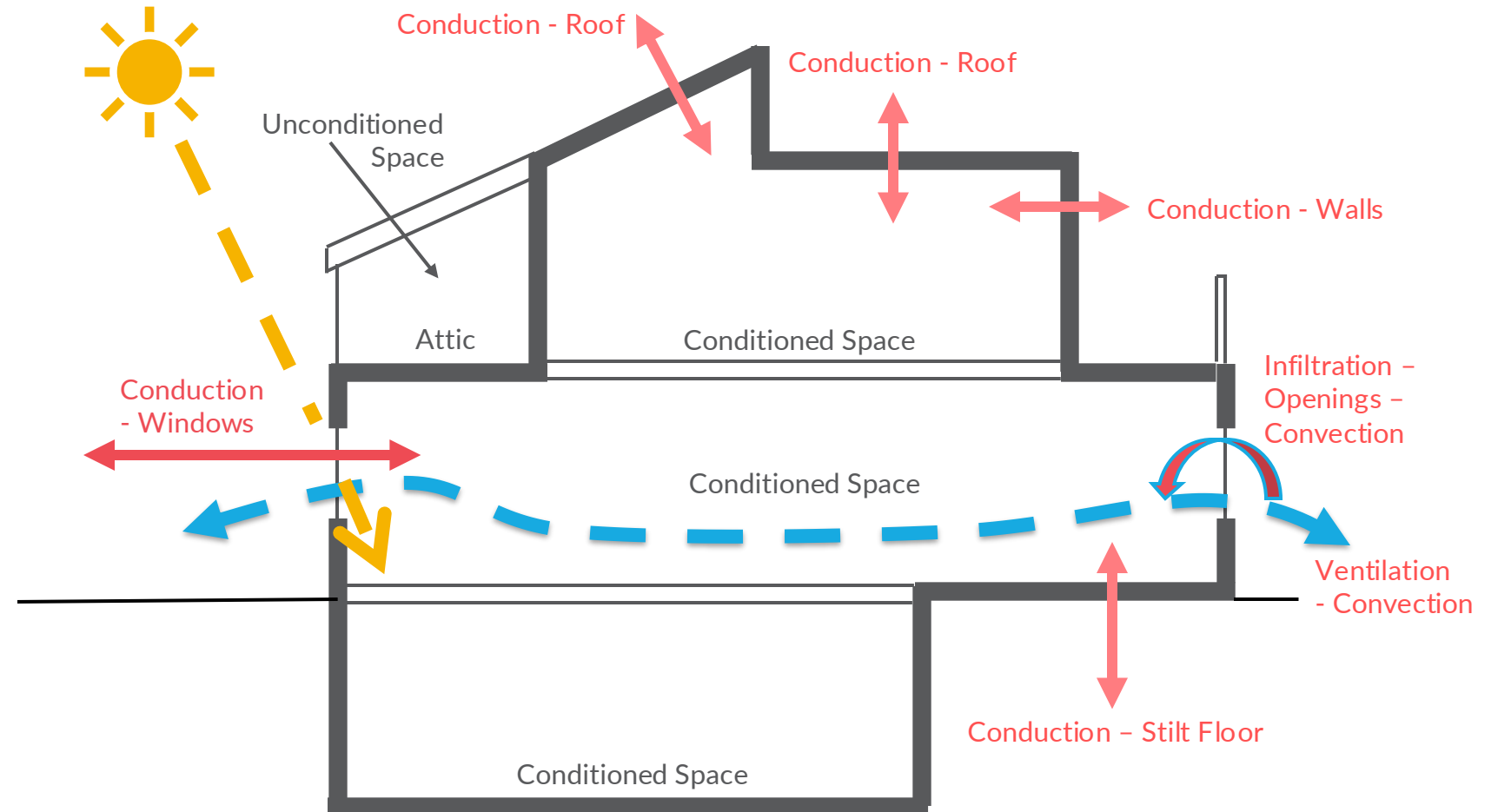

# THERMAL COMFORT

## Important parameters

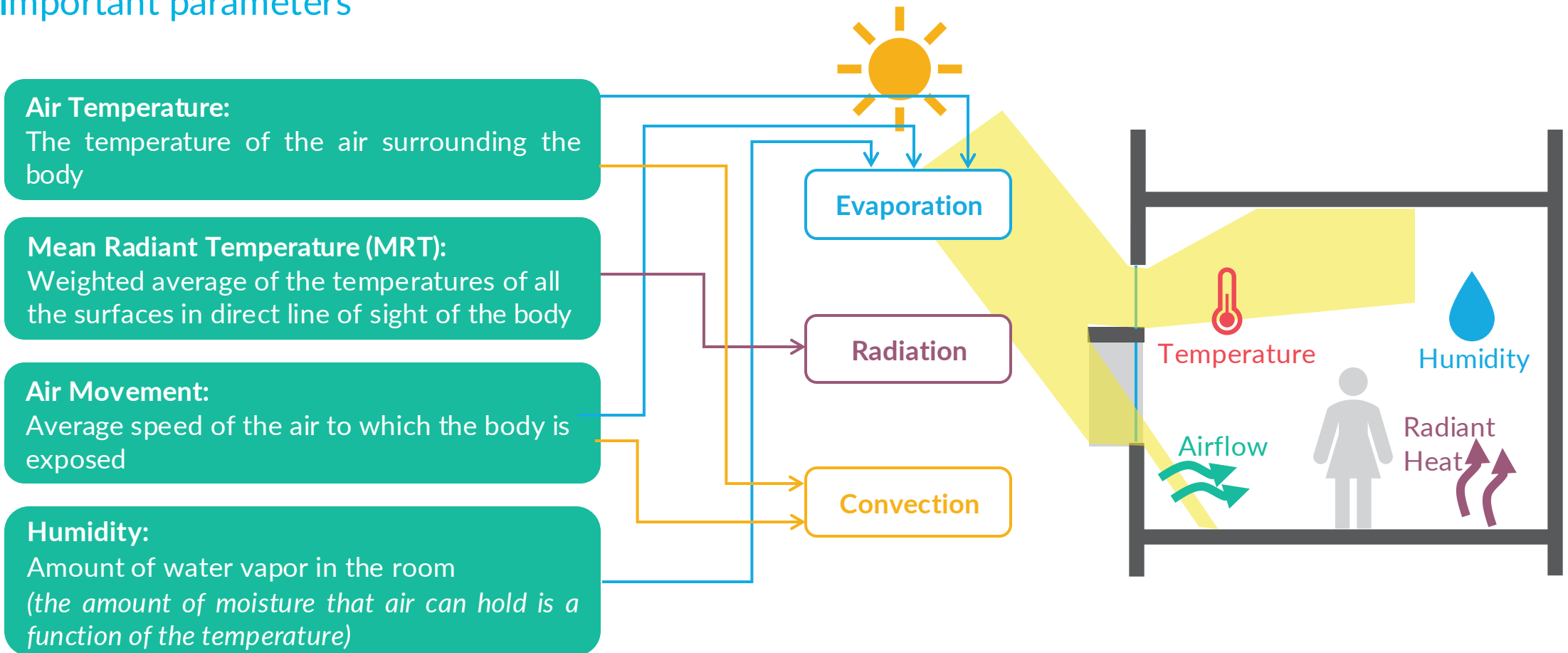

Source: BEEP Training Modules on Radiant Cooling

# Thermal Comfort

Adaptive Thermal Comfort Band



# ASHRAE STANDARDS

Building energy efficiency, adaptive comfort and ventilation

Internationally-accepted standards are:

- **American Society of Heating, Refrigerating and Air-Conditioning Engineers (ASHRAE) Standard 90.1: Energy efficiency of the system**
  - Heating, ventilation and air conditioning (HVAC)
  - Lighting
  - Equipment
  - Hot water
- **ASHRAE Standard 55: Adaptive comfort**
- **ASHRAE Standard 62.1: Ventilation system including fresh air**

# ADAPTIVE COMFORT

## Thermal preference

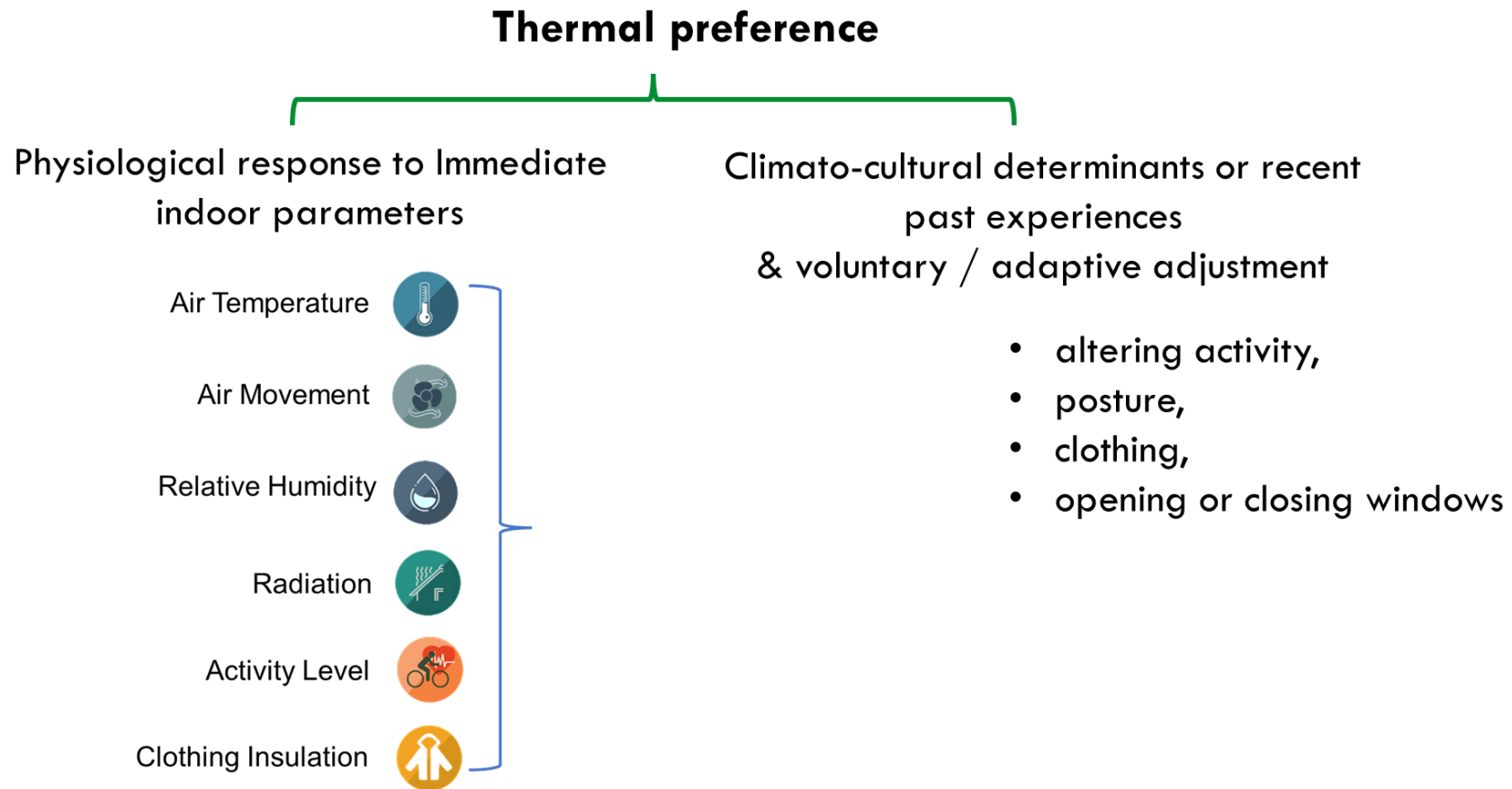

# ADAPTIVE COMFORT MODEL

ASHRAE

The acceptable indoor operative temperatures ( $t_o$ ) can be determined from the graph

OR

using the equations

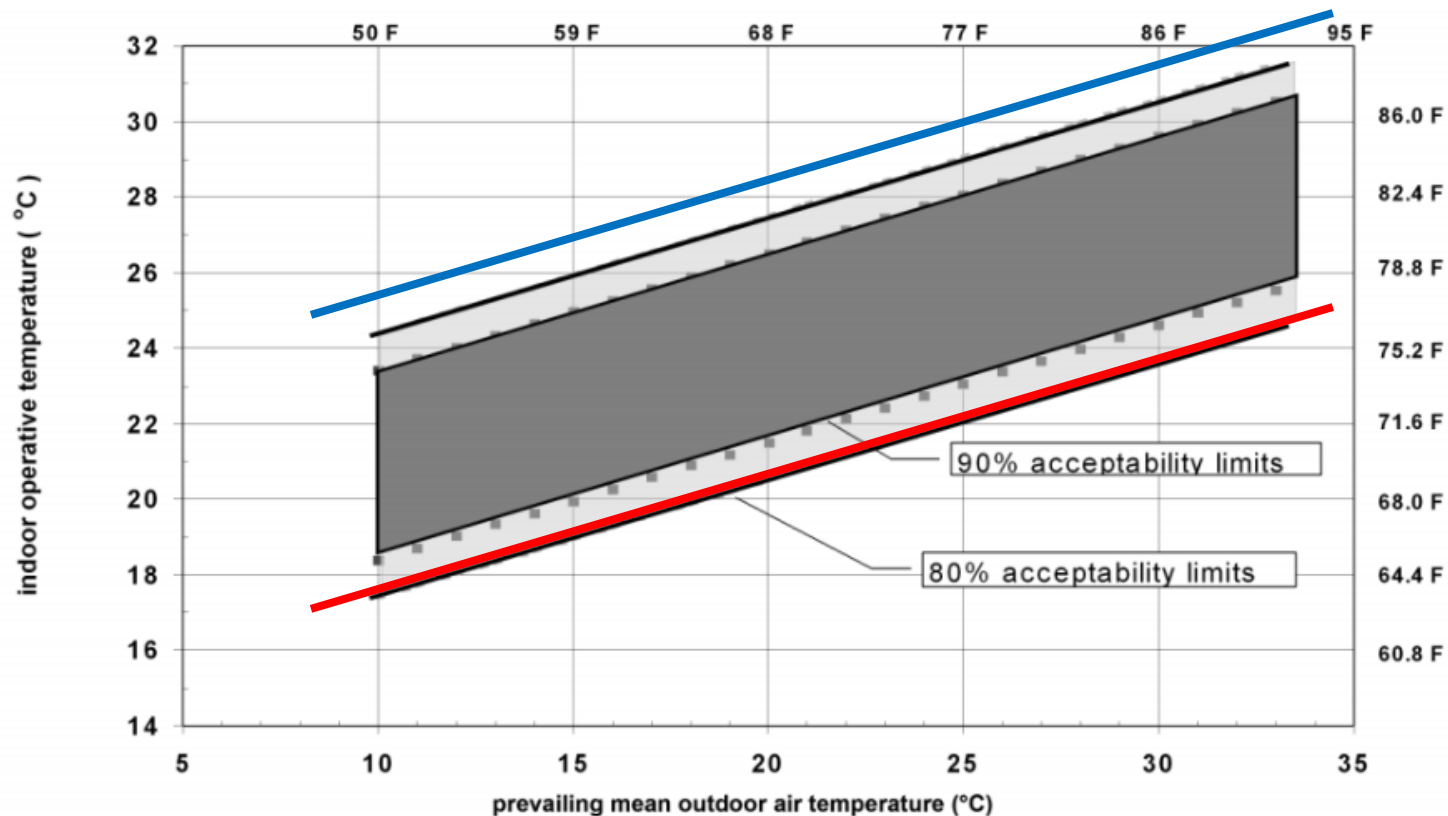

$$\text{Upper 80\% acceptability limit (}^\circ\text{C)} \\ = 0.31 t_{pma(out)} + 21.3$$

$$\text{Lower 80\% acceptability limit (}^\circ\text{C)} \\ = 0.31 t_{pma(out)} + 14.3$$

$t_{pma(out)}$  is the arithmetic average of the mean daily outdoor temperatures over no fewer than 7 and no more than 30 sequential days prior to the day in question

# AIR MOVEMENT

## Essential for thermal comfort

It is common experience that air movement, be it natural breeze, or forced draft from a fan, has a cooling effect that depends on the velocity of that air movement

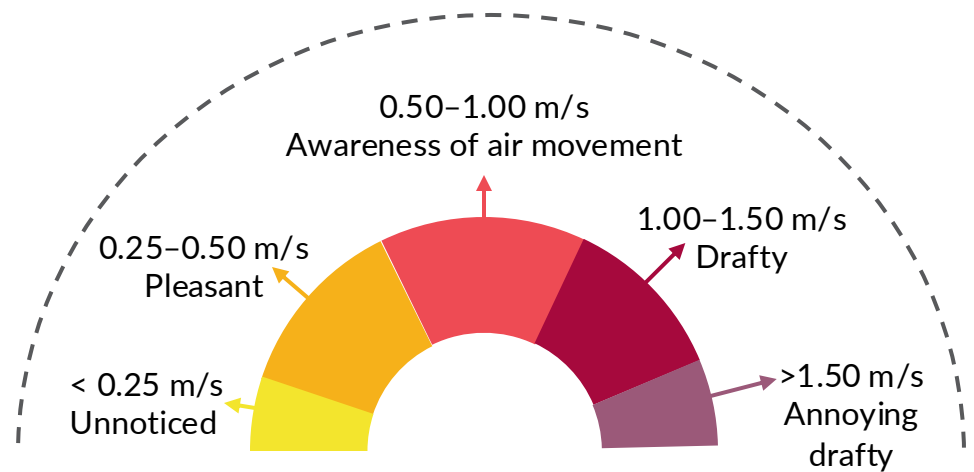

Average subjective reactions to various velocities under everyday conditions

Human responses to varied velocities depend on the temperature of the air

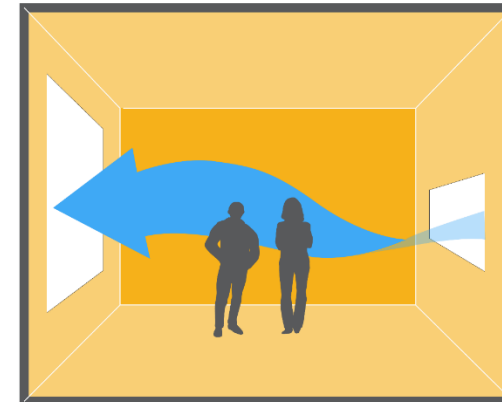

Under warm conditions, 1 m/s is pleasant and indoor air velocities up to 1.5 m/s are acceptable

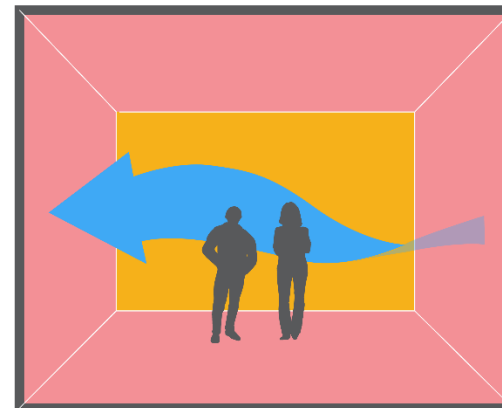

In a heated room, stagnant air (velocities < 0.1 m/s) may be judged as 'stuffy'

# ADAPTIVE THERMAL COMFORT

Works better with occupant participation and control

- Behavioral adaptation refers to any conscious or unconscious actions by a person to alter their body's thermal balance, e.g., choice of clothes, activity levels, using fans / heaters, and adjustment of diffusers or thermostats
- Behavioral adjustments offer the best opportunity for people to participate in maintaining their own thermal comfort with optimal energy consumption
- Providing ample opportunities for people to control the indoor climate is an essential strategy in the design of naturally-ventilated buildings. However, in most buildings, occupants have limited understanding and control



Case example: Integrating smart ceiling fans and communicating thermostats to provide energy efficient comfort

# ADAPTIVE COMFORT MODEL

## Limitations of ASHRAE Standard 55

- Those advocating more flexible thermal comfort standard have long argued that the primary limitation of ASHRAE Standard 55 is its one-size-fits-all approach
- In ASHRAE 55, clothing and activity are the only modifications one can make to reflect seasonal differences in occupant requirements
- Using ASHRAE Standard 55 to determine acceptable indoor temperature ranges requires assumptions about the average metabolic rate and clothing worn by people
- In contrast, an adaptive model relates acceptable indoor temperature range to the mean monthly outdoor temperature, defined as the arithmetic average of mean monthly minimum and maximum air temperature

# ADAPTIVE COMFORT MODEL

For Phnom Penh, Cambodia

Phnom Penh, Cambodia – ASHRAE Standard 55 – Comfort Band (80%)

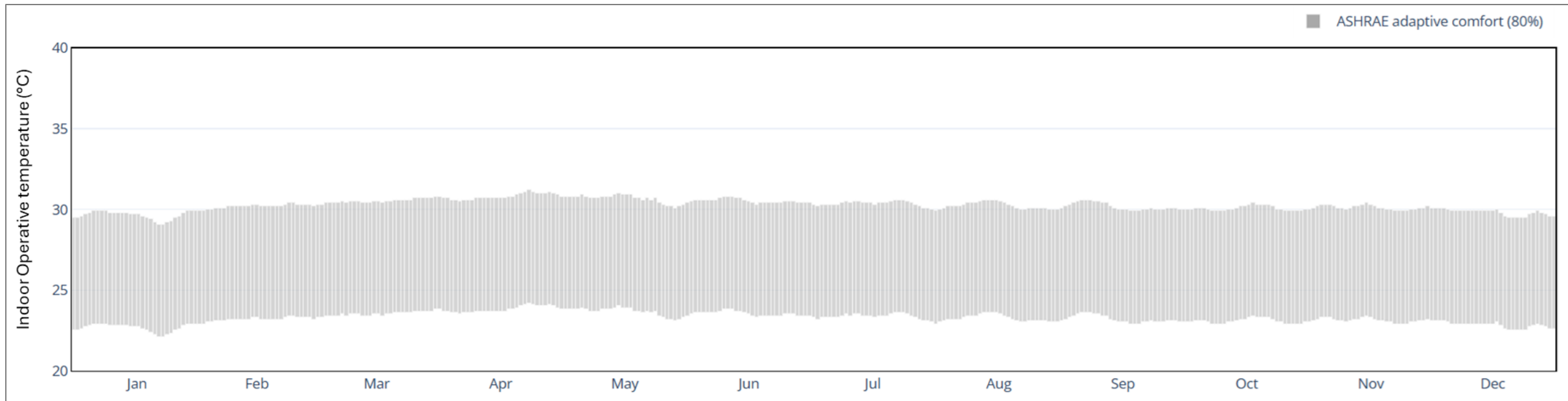

Source: Betti et al., 2023

# ADAPTIVE COMFORT MODEL

For Battambang, Cambodia

Battambang, Cambodia – ASHRAE Standard 55 – Comfort Band (80%)

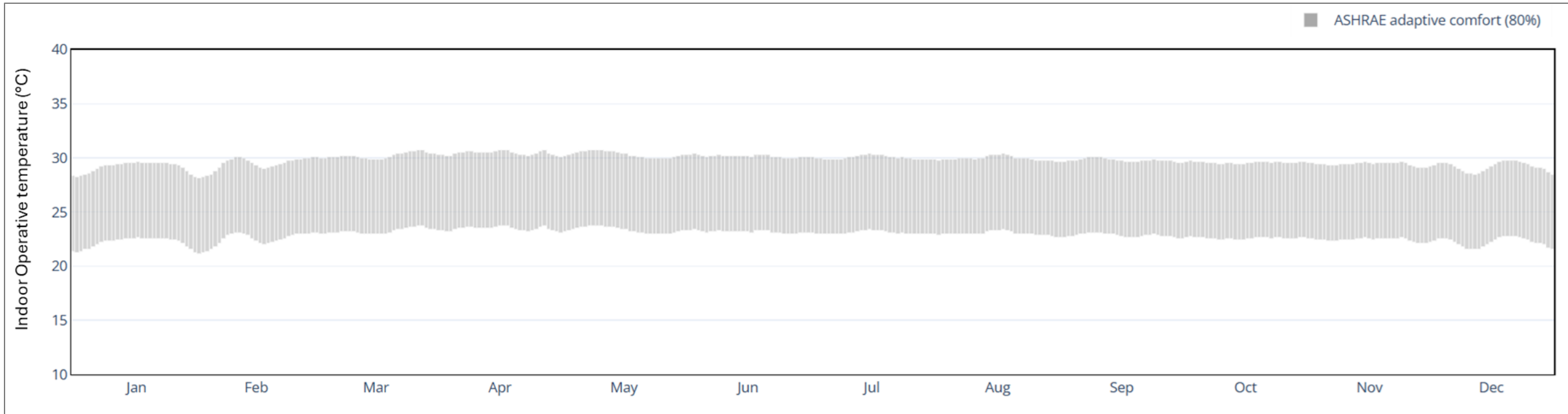

Source: Betti et al., 2023

# INDIA'S IMAC

## India's model for adaptive comfort

The India Model for Adaptive Comfort (IMAC) predicts the thermal comfort range in India for different months of the year, based on field studies in five cities. Some insights from the IMAC model are:

- A **single adaptive model** is proposed for 'naturally ventilated' and 'air conditioned' modes of operation
- Indian office occupants are **more adaptive** than predicted by ASHRAE-55 and EN15251 models
- **International comfort standards are not appropriate** for Indian office buildings
- **Occupants in 'mixed-mode' offices** are more adaptive than those in air-conditioned offices, and less adaptive than those in naturally-ventilated offices
- Use of fans and windows and appropriate clothing are significant adaptive measures in naturally-ventilated offices

Source: Manu et al., 2016

# INDIA'S IMAC

Composite climate

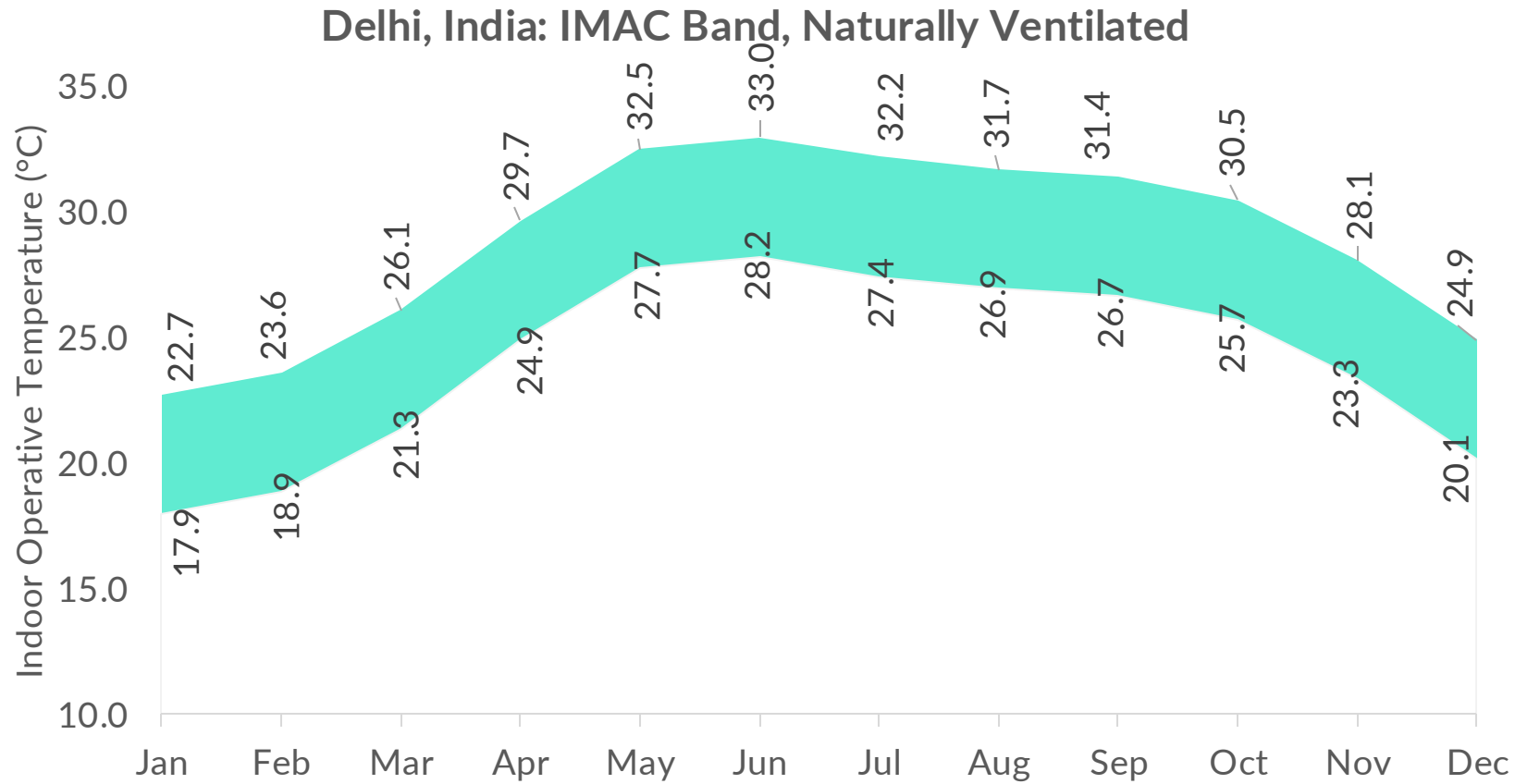

# INDIA'S IMAC

Warm and humid climate

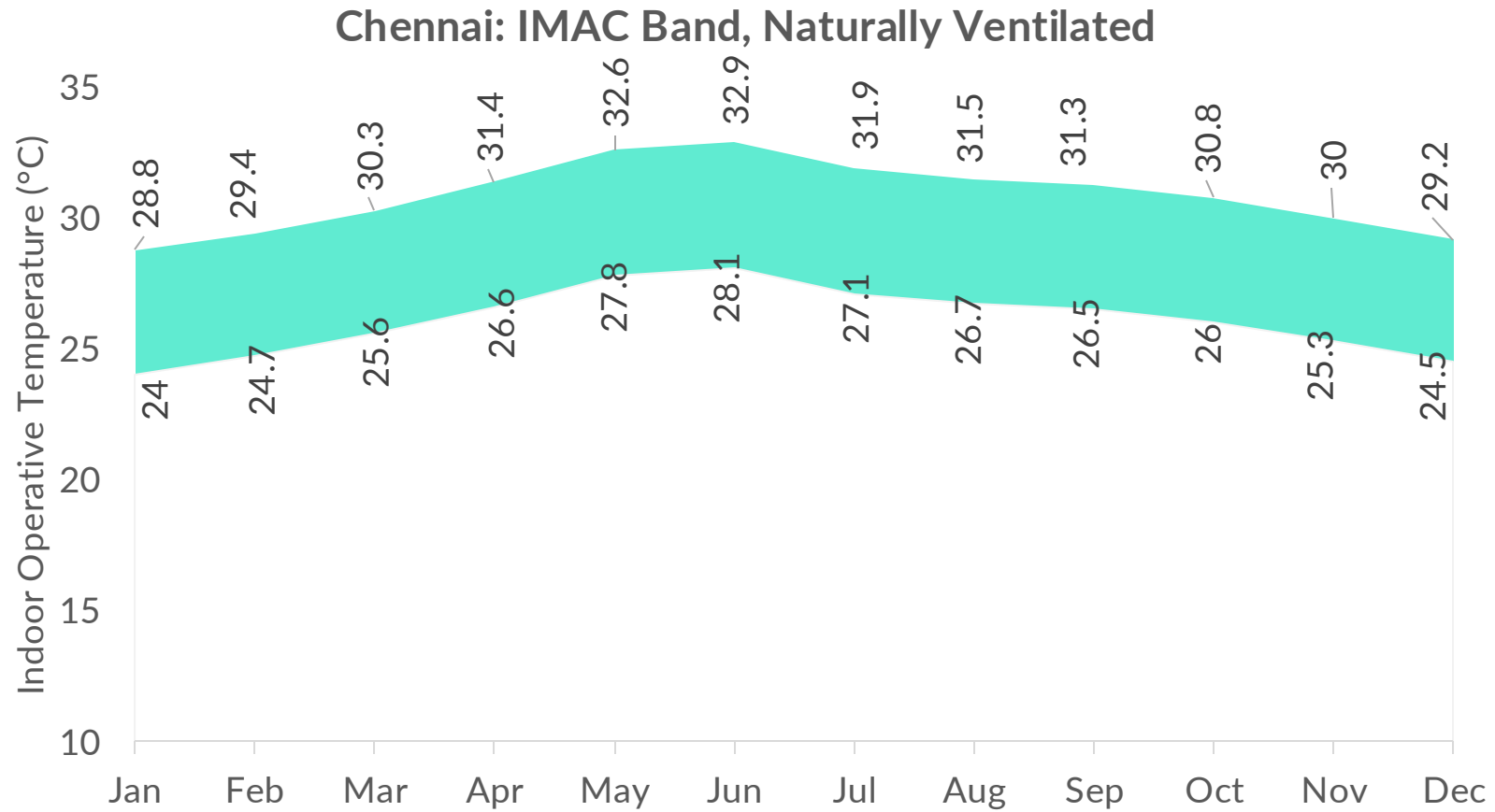

# INDIA'S IMAC

Hot and dry climate

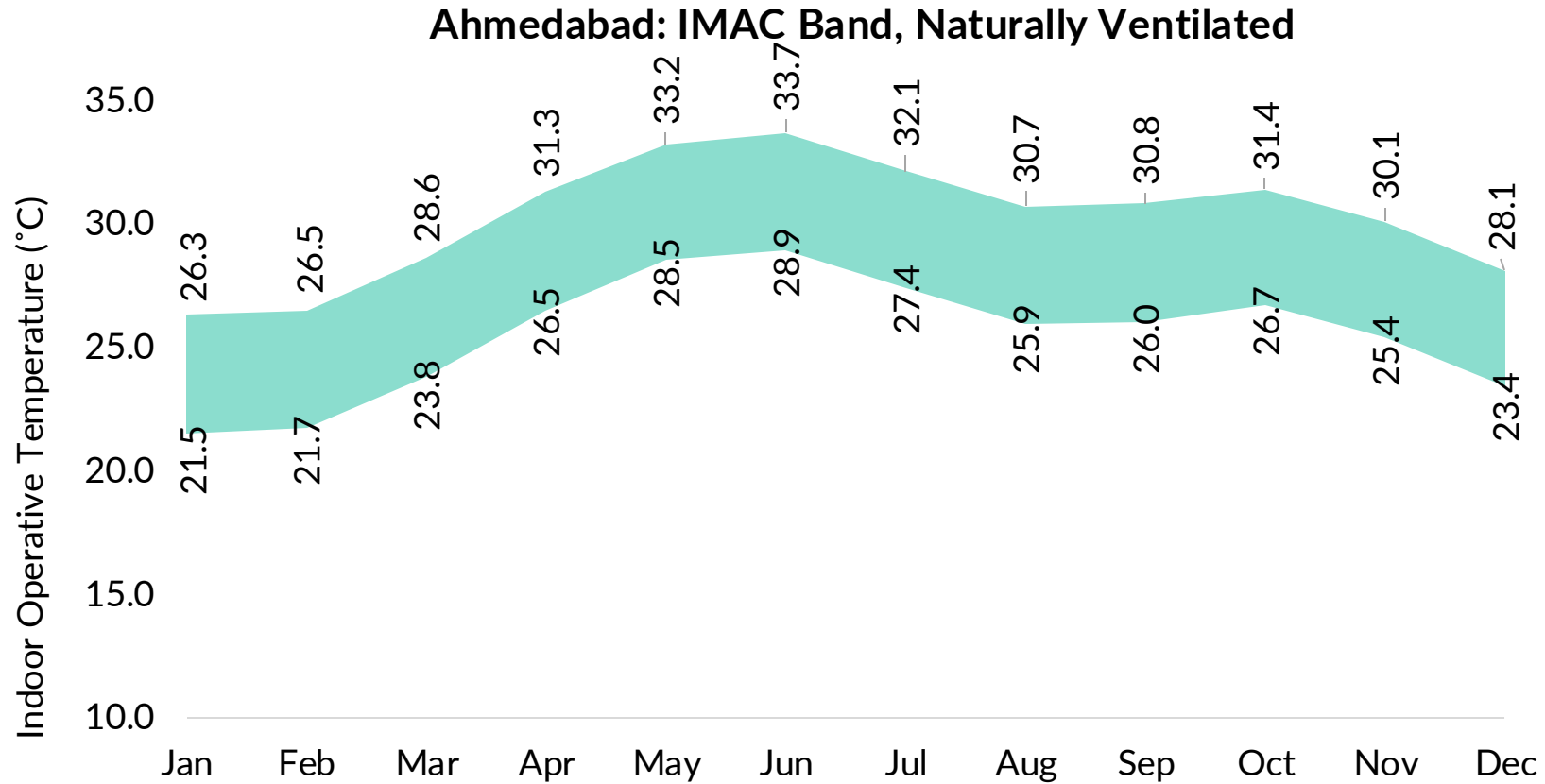

# INDIA'S IMAC

Temperate climate

Bengaluru: IMAC Band, Naturally Ventilated

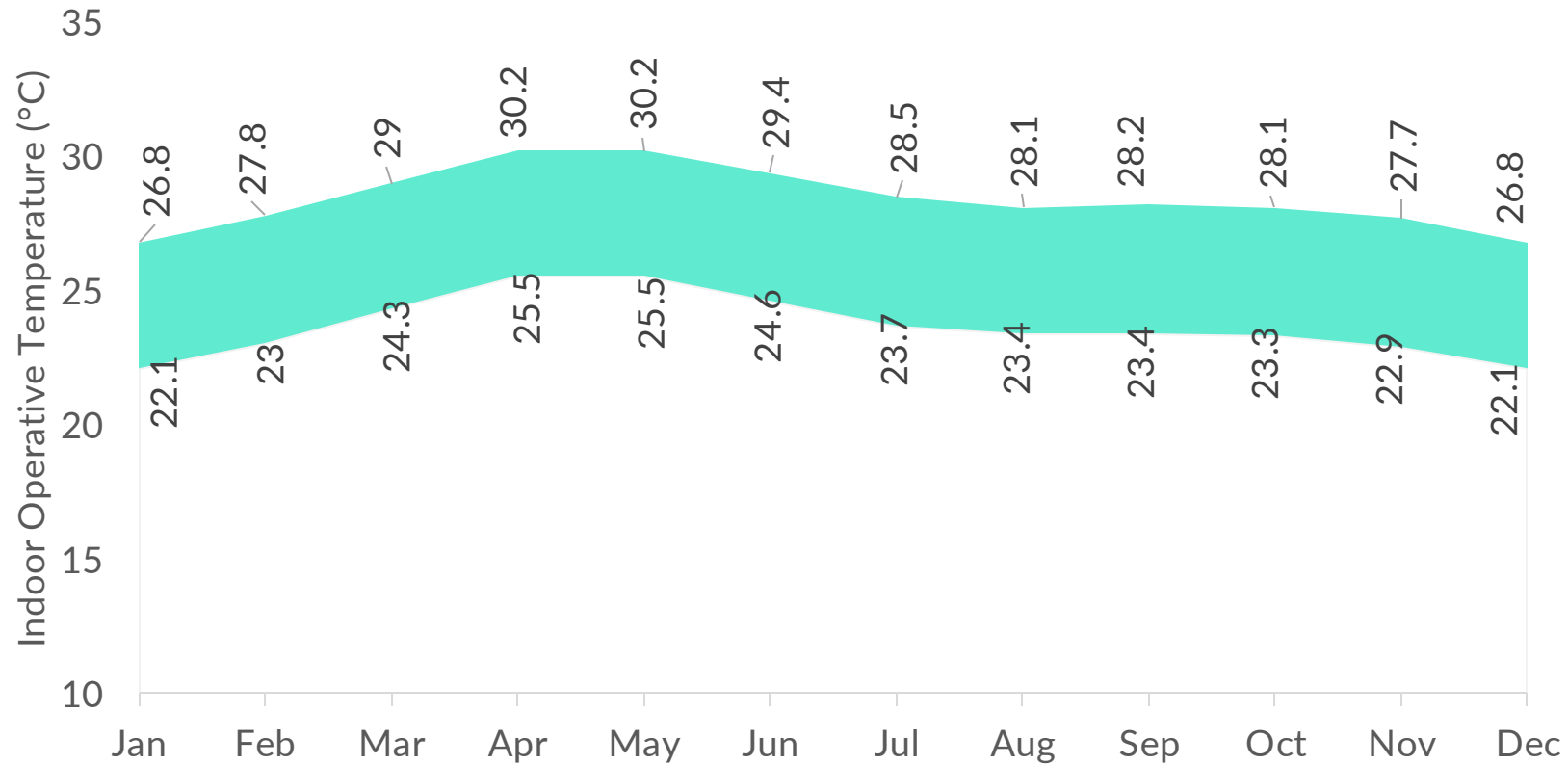

# TROPICAL SUMMER INDEX

For estimating room comfort temperatures with varying ambient temperatures

Naturally-ventilated Building

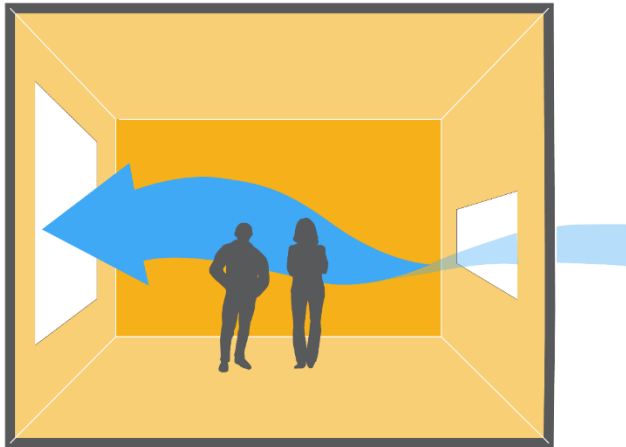

$$\text{Indoor Operative Temperature, } ^\circ\text{C} \\ = (0.54 \times \text{Outdoor Temperature}) + 12.83$$

- Indoor temperature is neutral and outdoor temperature is 30 days outdoor mean air temperature
- 90% acceptability range for India-specific adaptive models is  $\pm 2.38^\circ\text{C}$   
e.g.,  $(0.54 \times 33) + 12.83 = 30.68^\circ\text{C}$

Air-conditioned Building

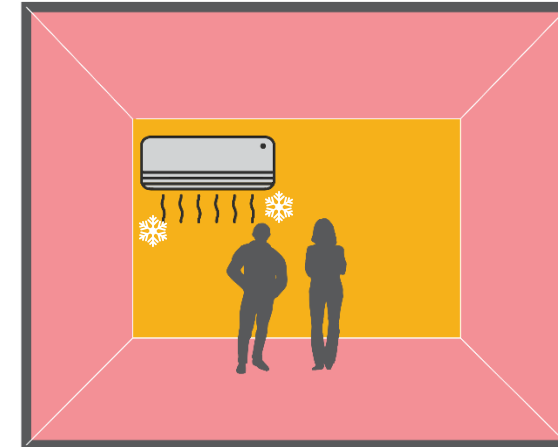

$$\text{Indoor Operative Temperature, } ^\circ\text{C} \\ = (0.078 \times \text{Outdoor Temperature}) + 23.25$$

- 90% acceptability range for India-specific adaptive models is  $\pm 1.5^\circ\text{C}$

$$\text{e.g., } (0.078 \times 33) + 23.25 = 25.8^\circ\text{C}$$

Source: Bureau of Indian Standards, Government of India, 2016b

# COMFORT PERCEPTIONS

## Human conditioning

Naturally-ventilated Building

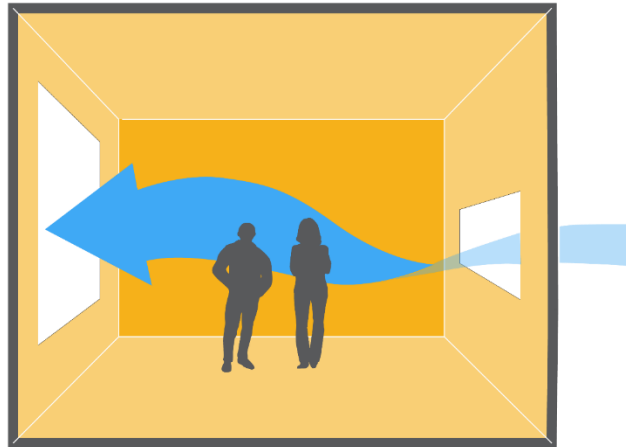

Naturally-ventilated buildings, where occupants can open windows, create indoor conditions that are inherently more variable than buildings with centralized HVAC systems

Air-conditioned Building

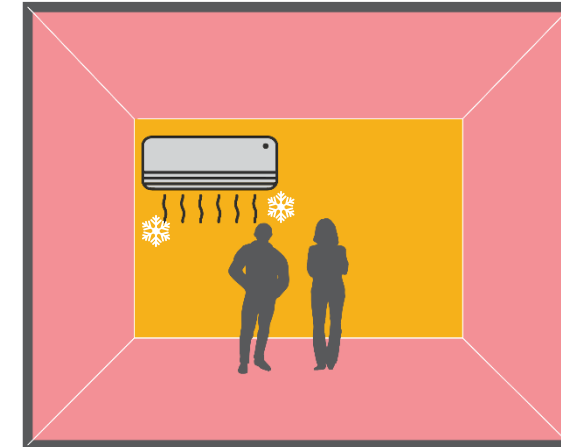

Research has demonstrated that occupants of buildings with centralized HVAC systems become finely tuned to the very narrow range of indoor temperatures presented by the prevailing HVAC practice

Considerable research is now focusing on three primary modes of adaptation

**Physiological**

**Behavioral**

**Psychological**

Source: Bureau of Indian Standards, Government of India, 2016b

# Adaptive Thermal Comfort

## Potential Solutions



Image source: <https://nzeb.in/a-paradigm-for-thermal-comfort-for-nzebs-in-tropics/>

# CLIMATE RESPONSIVE BUILDING DESIGN

Potential solutions are covered in subsequent sub-modules 2.2(b), 2.2(c), 2.3 and 2.5

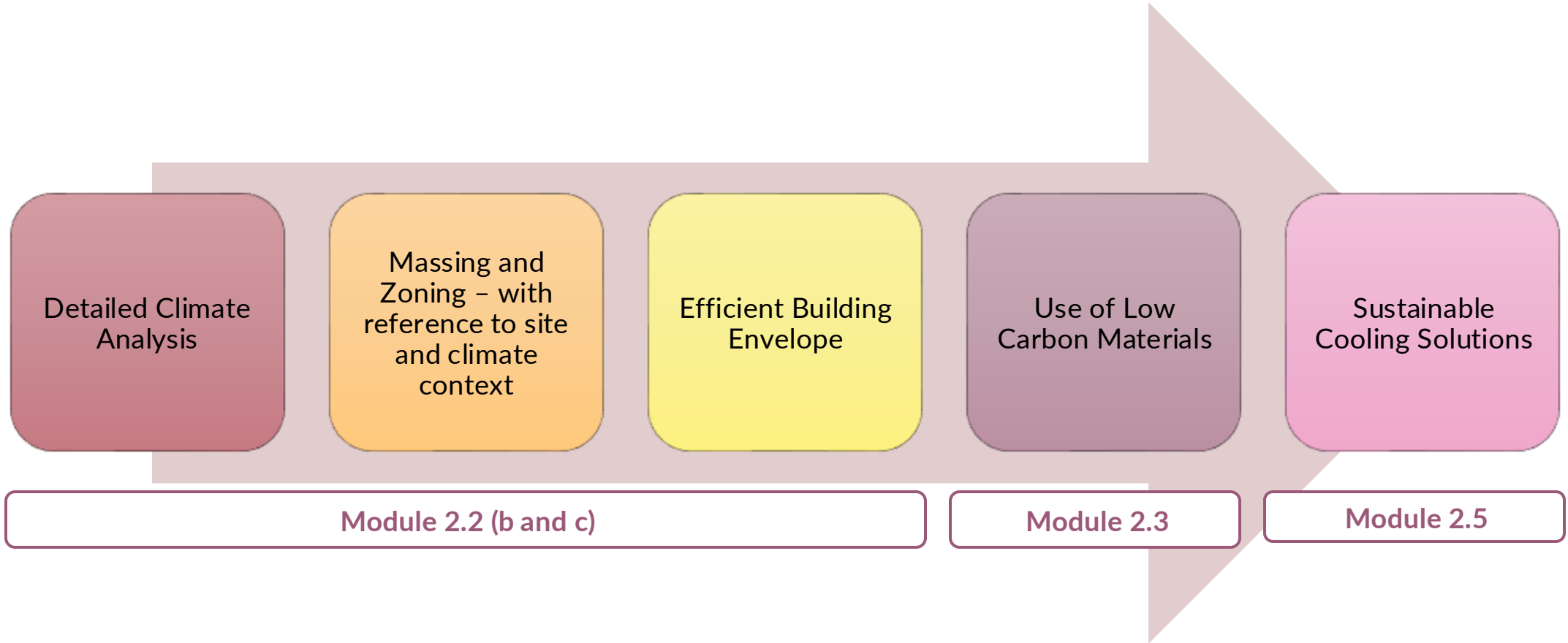

# Thank you!

For more information, visit us at <https://ALCBT.GGGI.ORG>  
or scan the QR code below



## IKI Independent Complaint Mechanism

Any person who believes they may be harmed by an IKI project or who wish to report corruption or the misuse of funds, can lodge a complaint to the IKI Independent Complaint Mechanism at [IKI-complaints@z-u-g.org](mailto:IKI-complaints@z-u-g.org). The IKI complaint mechanism has a panel of independent experts who will investigate the complaint. In the course of the investigation, we will consult with the complainant so as to avoid unnecessary risks for the complainant. More information can be found at <https://www.international-climate-initiative.com/en/about-iki/values-responsibility/independent-complaint-mechanism/>.

 [www.gggi.org](http://www.gggi.org)

 [@gggi\\_hq](https://twitter.com/gggi_hq)

 [@GGGIHQ](https://www.instagram.com/gggi_hq)

 [@GGGIHQ](https://www.facebook.com/gggi_hq)

 [@gggi\\_hq](https://www.linkedin.com/company/gggi_hq)

 [@GGGIMedia](https://www.youtube.com/channel/UCGgI-Media)



Supported by:



on the basis of a decision  
by the German Bundestag



## 2.4 Sustainable Cooling Solutions

November 2024

# WHAT WILL YOU LEARN?

## Sustainable Cooling and its Need

01

## Approach

02

## Technologies

03

## Refrigerants

04

## Services, Policies and Financial Solutions

05

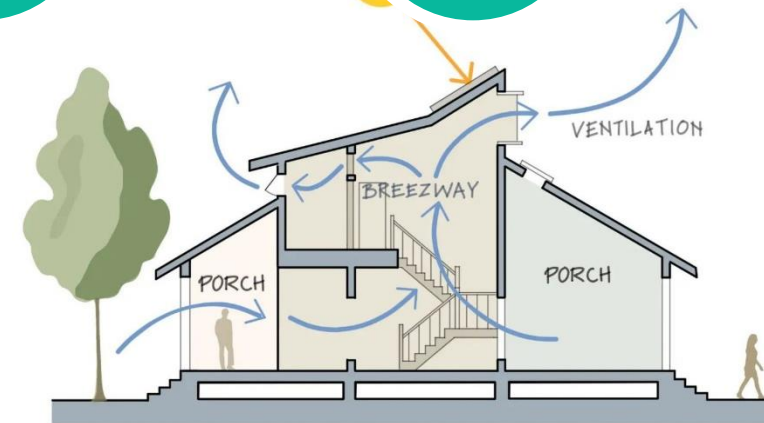
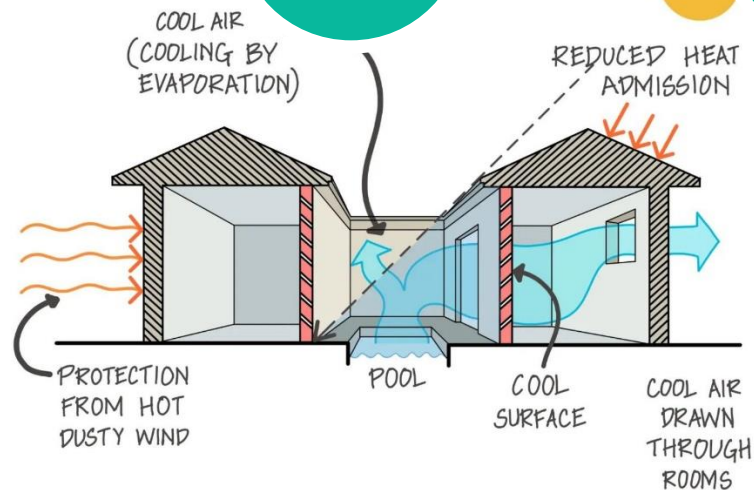

Image source: <https://www.arch2o.com/passive-cooling-systems/>

# Sustainable Cooling

## Needs and Relevance









Image source: <https://www.ecohome.net/guides/1451/stay-cool-the-old-fashioned-way/>

# FUNDAMENTAL COOLING NEEDS

## Basic applications

- **Comfort and safety:** For human thermal comfort and associated well-being; for productivity and linked incomes; and safety and health in extreme weather conditions
- **Food and nutrition:** For the agriculture sector to have access to cooling for food and nutrition security, rural incomes, and the agriculture cold chain
- **Health and care:** For safe medical clinics and the secure transport and storage of vaccines and medical products

	Thermal comfort		Removing heat and maintaining stable temperatures for industrial and commercial purposes		Maintaining stable temperatures for food and medicine transport and preservation		
Application	Mobile Air Conditioning	Space Cooling	Industrial Refrigeration	Commercial Refrigeration	Transport Refrigeration	Domestic Refrigeration	
	Cooling in passenger cars, commercial vehicles, buses, trains, planes etc.	Indirect district cooling and room air conditioning or fans for human comfort and safety in buildings	Used on farms, and in food processing (including marine) and pharmaceutical factories and product distribution centres	Used in supermarkets, restaurants and other retail premises, e.g. display cabinets and cold rooms	Movement of goods over land and sea, preserving their safety and quality, and extending shelf life	Safe storage of food and extension of its shelf life	
							
Technology	Mobile ACs	Heat pumps Unitary ACs	AC chillers	Industrial refrigeration equipment	Commercial refrigeration equipment	Transport refrigeration units (TRUs) including shipping containers	Domestic refrigerators
							

Source: Sustainable Energy for All, 2019

# SPACE COOLING

## Emissions impact

1 Gt CO<sub>2</sub>e

Global CO<sub>2</sub> emissions from electricity use for space cooling (2022)<sup>1</sup>

0.72 Gt CO<sub>2</sub>e

Global non-CO<sub>2</sub> GHG emissions associated with the leakage of refrigerants used in space cooling (2022)<sup>2</sup>

3.2%

Percentage of total global GHG emissions<sup>2</sup>

Sources:

<sup>1</sup> International Energy Agency

<sup>2</sup> Ritchie, 2024

# CONVENTIONAL AIR CONDITIONING

## Emissions impact

- Conventional air conditioning is mainly based on **vapor compression refrigeration cycle technology**. This technology exploits a basic law of physics: when a liquid converts to a gas (in a process called phase conversion), it absorbs heat; and when it condenses again (to a liquid), it releases heat
- Air conditioning equipment uses phase conversion by forcing either natural or special chemical compounds, known as refrigerants, to evaporate and condense repeatedly in a closed loop of coils
- **Most refrigerants in use today are synthetic chemical compounds, with significant global warming potential**

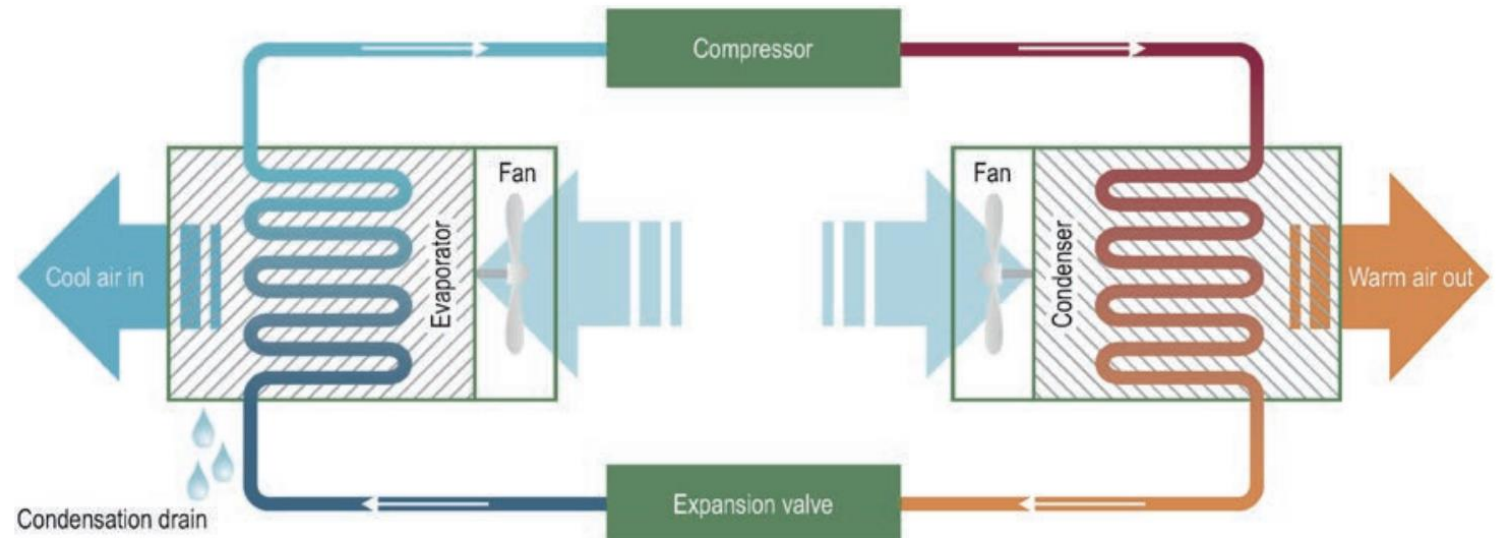

Source: International Energy Agency, 2018

# CONVENTIONAL AIR CONDITIONING

Major contributor to global warming

- **Air conditioning is energy intensive.** It is largely dependent on grid electricity, predominantly fueled by fossil fuels, indirectly driving greenhouse gas emissions
- **Uses refrigerants with overwhelmingly high global warming potential,** responsible for direct greenhouse gas emissions
- **Contributes to urban heat islands** by rejecting waste heat into the outdoors, thus warming the urban environment



Source: United Nations Environment Programme, 2021a

# SUSTAINABLE COOLING

## Implication

- **Sustainable or 'clean' cooling** means cooling that uses climate-friendly refrigerants and without other environmental damage including climate impact, in line with the objectives of the Paris Agreement on Climate Change and the Montreal Protocol
- Clean cooling must be accessible and affordable to help deliver societal, economic and health goals

### Cooling needs, solution approach and solution pillars



Source: United Nations Environment Programme and International Energy Agency, 2020

Image source: <https://www.seforall.org/chilling-prospects-2020/sustainable-cooling-solutions>

# SUSTAINABLE COOLING

## The need

- Heat waves and related droughts have devastated lives and livelihoods across the globe in recent years. Many of the world's most vulnerable people have limited or no access to modern cooling technologies like air conditioners
- Cooling is increasingly being understood as a critical infrastructure service, akin to energy, water and others. Without adequate cooling, achieving global Sustainable Development Goals (SDGs) will be increasingly challenging
- It is urgent to meet people's needs for cooling and heat adaptation while also achieving GHG mitigation and development goals, conserving natural resources and improving the local environment. This requires a rapid transition to sustainable cooling

## Cooling needs, solution approach and solution pillars



Source: United Nations Environment Programme and International Energy Agency, 2020

Image source: <https://www.seforall.org/chilling-prospects-2020/sustainable-cooling-solutions>

# Sustainable Cooling

## Approach



# URBAN HEAT ISLAND

## Heating up cities

- An urban heat island (UHI) is a **metropolitan area that is significantly warmer than its surroundings**
- Many US cities have air temperatures up to 5.6°C warmer than the surrounding natural land cover
- This temperature difference is usually larger at night than during the day, and larger in winter than in summer, and is most apparent when winds are weak
- The main causes are changes in the land surface by urban development along with waste heat generated by energy use
- With the growth in urban centers, greater areas of land tend to change, which then undergo a corresponding increase in average temperature

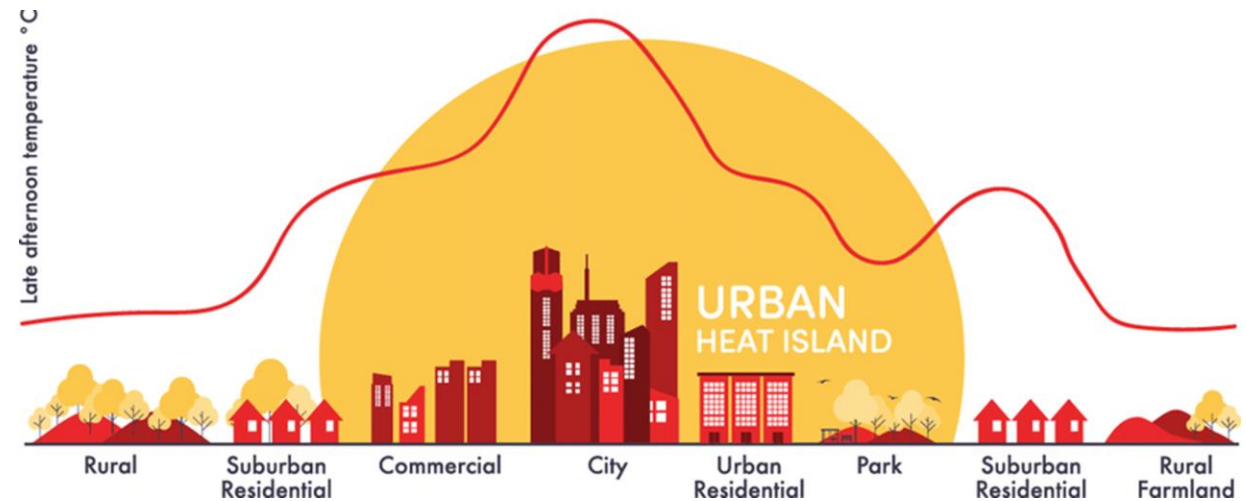

Source: University Corporation for Atmospheric Research

# SUSTAINABLE COOLING

## Holistic approach

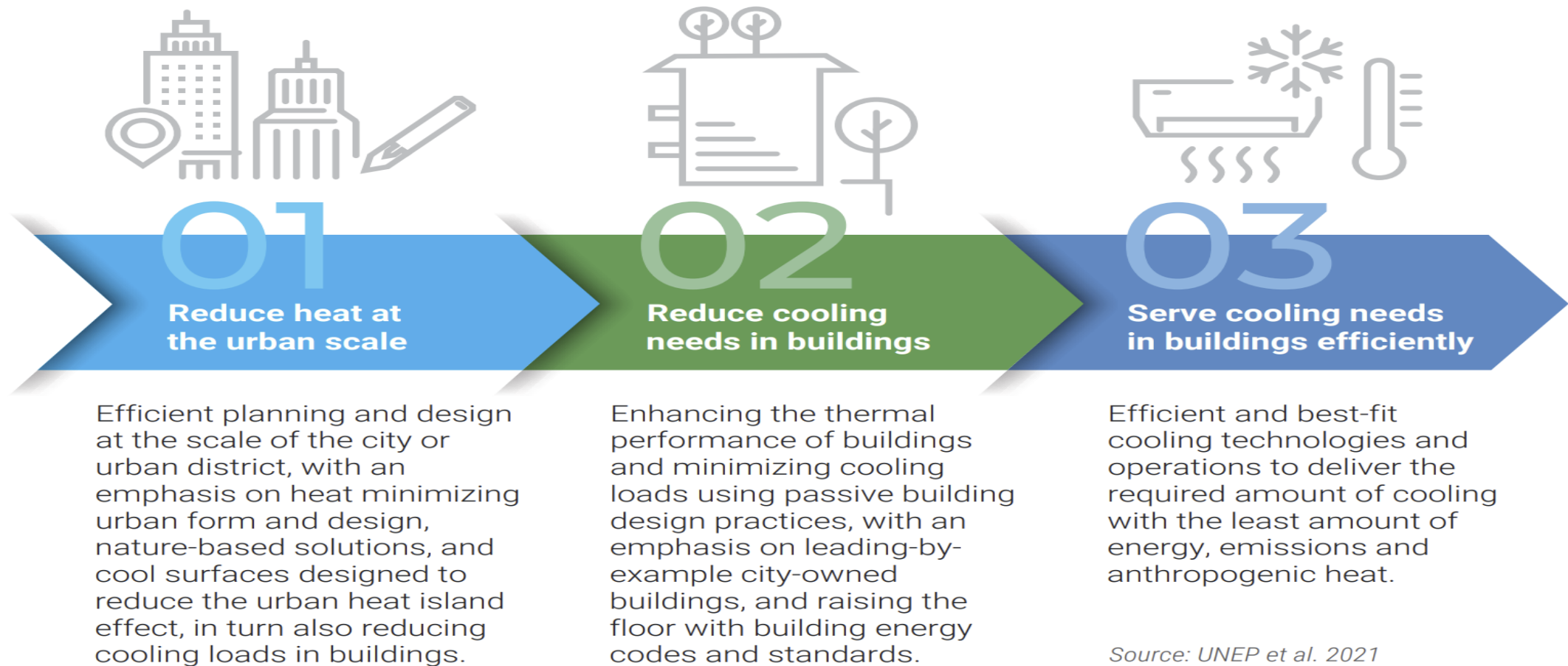

Source: United Nations Environment Programme, 2023

# SUSTAINABLE COOLING

Holistic approach for urban areas

## Urban form and planning

Land use and building design controls adjusted to maximize effectiveness and ensure that the density and form of new development is appropriate for future climate conditions. They include:

- Leveraging cooling benefits of green open spaces and water bodies
- Promoting wind flow
- Reducing waste heat

## Nature-based solutions

Integrating vegetation and water bodies in the urban fabric can reduce local and ambient temperature

## Cool surfaces

Reflective urban surfaces, such as for buildings and pavements, can make cities cooler

Source: United Nations Environment Programme, 2021a

# SUSTAINABLE COOLING

Holistic approach to reduction of cooling demand in buildings

Cooling loads of buildings can be minimized through **passive design strategies**:

- Climate-appropriate building orientation
- Appropriate materials and design features in the building envelope like insulation and shading to minimize heat gain due to thermal transmittance
- Natural ventilation where temperature, humidity and air quality allow
- Thermal mass to stabilize interior temperatures

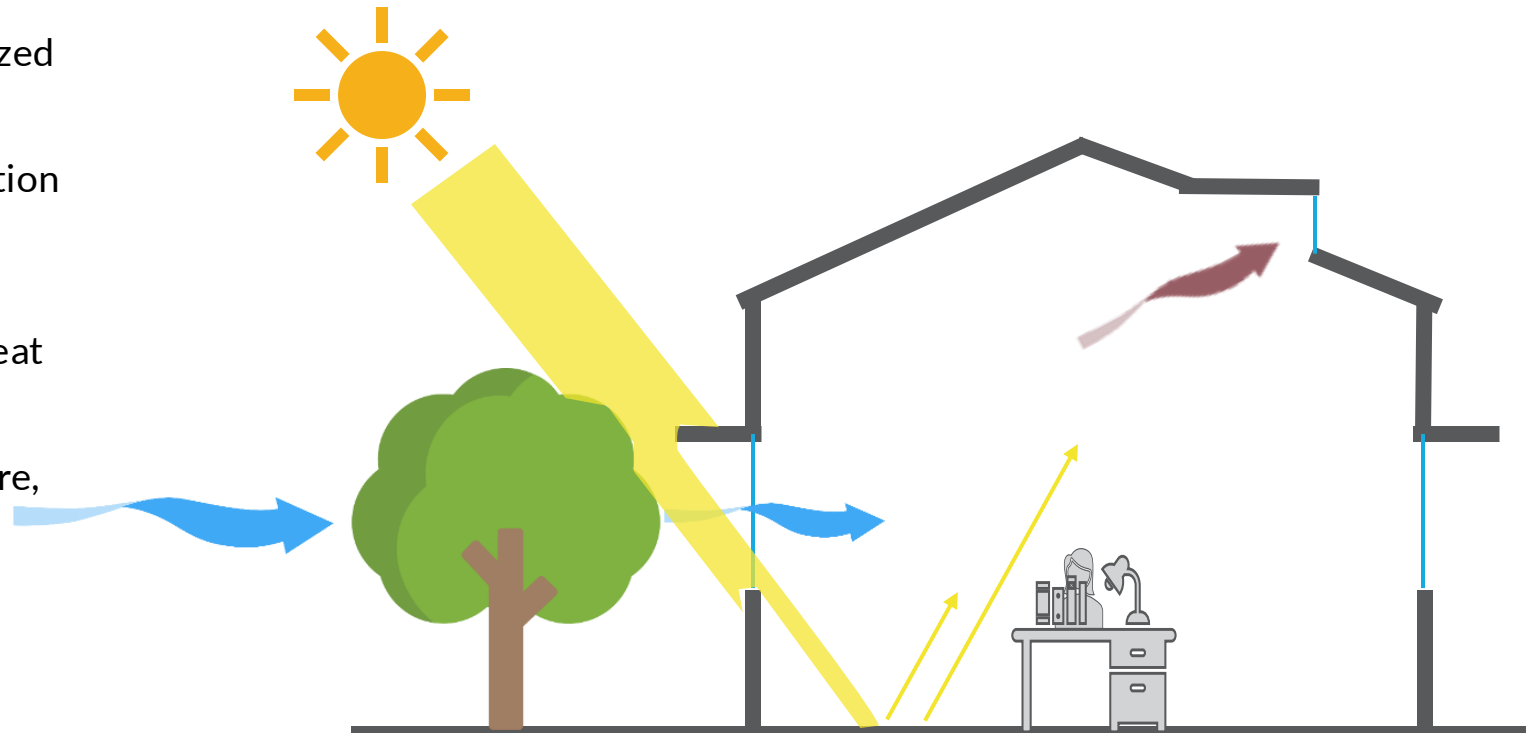

Source: United Nations Environment Programme, 2021a

# SUSTAINABLE COOLING

Serving cooling needs efficiently in buildings

## Selecting optimal cooling technology

A wide range of cooling technologies is available for buildings of different scales, climates etc. These can be made sustainable by:

- Improving minimum energy performance standards (MEPS)
- System design improvements to further improve energy efficiency
- Using low-GWP refrigerants

## Efficient operations

Optimizing cooling operations by ensuring that cooling is delivered only where and when it is needed, and system performance is monitored and maintained, can be achieved by:

- Use of controls and sensors
- Load shifting
- User adaptations and behavior changes
- Good operations and maintenance and servicing practices
- Capacity building of service sector

Source: United Nations Environment Programme, 2021a

# Sustainable Cooling

## Technologies



Image source: <https://fridgesworld.co.uk/blogs/news/sustainable-cooling-solutions-chillpro-s-commitment-to-eco-friendly-refrigeration-and-display->

# SPACE COOLING

## Generic technologies

### Refrigerant-based cooling

- Residential buildings: Room air conditioner (RAC)
- Commercial buildings: Room air conditioner (RAC), chiller system, packaged direct expansion (DX) and variable refrigerant flow (VRF) system

### Non-refrigerant-based cooling

- Fans and air coolers
- Significantly pervasive in the residential sector
- These do not provide the full utility that refrigerant-based vapor-compression cooling provides across all climatic conditions today

### Not-in-kind cooling

- Non-vapor compression cooling technologies, most of which use no or low-GWP refrigerants

Sources: Ministry of Environment, Forest and Climate Change, Government of India, 2019; Khosla et al., 2022

# REFRIGERANT-BASED COOLING

## Overview



### Room Air Conditioner

Non-ducted unitary systems, including mini or single split (fixed-speed and inverter types) and window/through-the-wall (fixed-speed type) configurations



### Chiller System

Chiller systems (central chilled-water air conditioning systems) are the preferred choice for large commercial buildings. Other than the chiller itself, which is the largest energy-consuming component, the system comprises various auxiliaries, including chilled water pumps, condenser water pumps, cooling tower fans, air handling units and fan coil units



### Variable Refrigerant Flow (VRF) System

Typically used in medium-size commercial buildings and high-income group residential units that have varying exposure and cooling loads. The outdoor units are connected to multiple types and numbers of indoor units, such as wall mounted, ceiling mounted cassette, ducted and DX AHUs



### Packaged DX

Ducted and packaged systems, including rooftop and indoor packaged units in commercial air conditioning segment (also known as unitary and light commercial systems), typically cater to small-to-medium commercial buildings to avoid the complexities associated with chiller systems

Source: Ministry of Environment, Forest and Climate Change, Government of India, 2019

# REFRIGERANT-BASED COOLING

## Efficiency improvements

### Multi-stage and Variable-speed Drives/Controls

- Modulating motor speed on compressors, the air conditioning system can more closely match the part-load cooling demand and improve seasonal efficiency by reducing losses when the system's full capacity is not required
- Variable-speed controls operate fan motors at their most efficient setting to meet the airflow needs of the system

### Advanced Compressors

- Air conditioning compressor efficiency and performance has steadily improved
- Larger systems use multiple compressors to stage capacity and improve part-load performance
- Magnetic and oil-free compressor technologies can deliver significant energy savings

### Improved Heat Exchangers

- Manufacturers have increased the size of heat exchangers (metal tube-and-fin) to improve system efficiency
- Advanced heat exchanger designs, such as microchannel heat exchangers and other small diameter designs, have further improved system efficiency, and reduced refrigerant charge, fan energy consumption and physical size

### Electronic Expansion Valves

- Thermostatic expansion valves (TXV) improve upon earlier static capillary tube and fixed orifice expansion devices by modulating refrigerant flow based on refrigerant superheat temperature at the evaporator exit
- Newer electronic expansion valves (EEV) provide increased modulation capabilities to match more closely the needs of variable-capacity air conditioning systems

Source: Ministry of Environment, Forest and Climate Change, Government of India, 2019

# REFRIGERANT-BASED COOLING

## Efficiency improvements (continued)

### High Efficiency Fans

- Many systems have incorporated more aerodynamic component designs (e.g., fan blades, condensing unit housing), high efficiency motors and variable-speed controls
- Manufacturers have applied these innovations to axial and centrifugal fans for both heat exchange and distribution of conditioned air throughout buildings

### High Efficiency Motors

- Improved motor designs have a significant impact on overall air conditioning system efficiency
- Electrically commutated motors (ECM) have higher efficiencies than permanent split capacitor (PSC) motors for air conditioning fans and operate at a wider range of conditions using electronic controls

### Advanced Controls

- Different occupancy sensing strategies can automatically alter thermostat setpoints when building occupants are away to reduce energy consumption
- Economizer controls enable air conditioning systems to use cooling energy from ventilation air or chilled-water cooling

Source: Ministry of Environment, Forest and Climate Change, Government of India, 2019

# ACCEPTABLE REFRIGERANTS

As per the Montreal Protocol

For new medium-temperature retail standalone units

- R-448A
- R-449A
- R-449B

For new residential and light commercial air conditioning and heat pumps

- R-32
- R-452B
- R-454A
- R-454B
- R-454C
- R-457A

Source: CAREL Industries

# NON-REFRIGERANT BASED COOLING

## Overview



Fan

Includes ceiling, pedestal, table and wall-mounted fans. They are widely used in the tropics, in the residential and small to mid-commercial segment. Despite a rise in the penetration of room air conditioner in households, a significant portion of the population will still not be able to afford air conditioning in the next two decades and will continue to rely on natural ventilation and fan-assisted ventilation for thermal comfort



Air Cooler and  
Evaporative  
Cooler

These require a climate that is hot and dry. Water is evaporated on cooling pads and ventilated into the building by fans. Evaporating water absorbs a significant amount of heat, cooling the air in the same way that perspiration enables humans and animals to cool themselves. It is an important cooling appliance for users, especially across households and medium-size commercial buildings in hot and dry and composite climates

Sources: Ministry of Environment, Forest and Climate Change, Government of India, 2019; International Energy Agency, 2018

# NON-REFRIGERANT BASED COOLING

## Advancements



**BLDC Fan**

Typically, ceiling fans contain single phase induction motors, consume 70–80W and deliver air at 230–250 m<sup>3</sup>/minute. Fans with brushless DC (BLDC) motors combined with better blade design have led to more efficient fans, which consume 30–35W and deliver air at 220–230 m<sup>3</sup>/minute

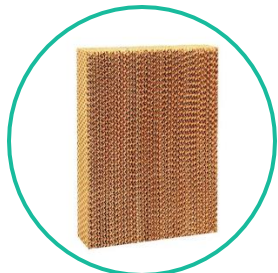

**Cooling Pad in Air Cooler**

The patterns used on cooling pads have a significant bearing on the water absorption and evaporation process. Aspen (wood wool) pads are 75% efficient and honeycomb are roughly 85% efficient. The cooling pad area is also important – steel body coolers have a larger cooling pad area compared to fiber body ones, and are more efficient

Source: Ministry of Environment, Forest and Climate Change, Government of India, 2019

# NOT-IN-KIND TECHNOLOGIES

## Overview

- Not-in-kind cooling technologies are non-vapor compression cooling technologies, most of them use no or low-GWP refrigerants
- Most of these technologies are still in low technological readiness levels
- More research is required to improve the performance of technologies of low to moderate maturity
- Supportive deployment-oriented policies are necessary to increase the installation of cooling technologies with moderate or high technical maturity, e.g., evaporative cooling, absorption cooling, etc.

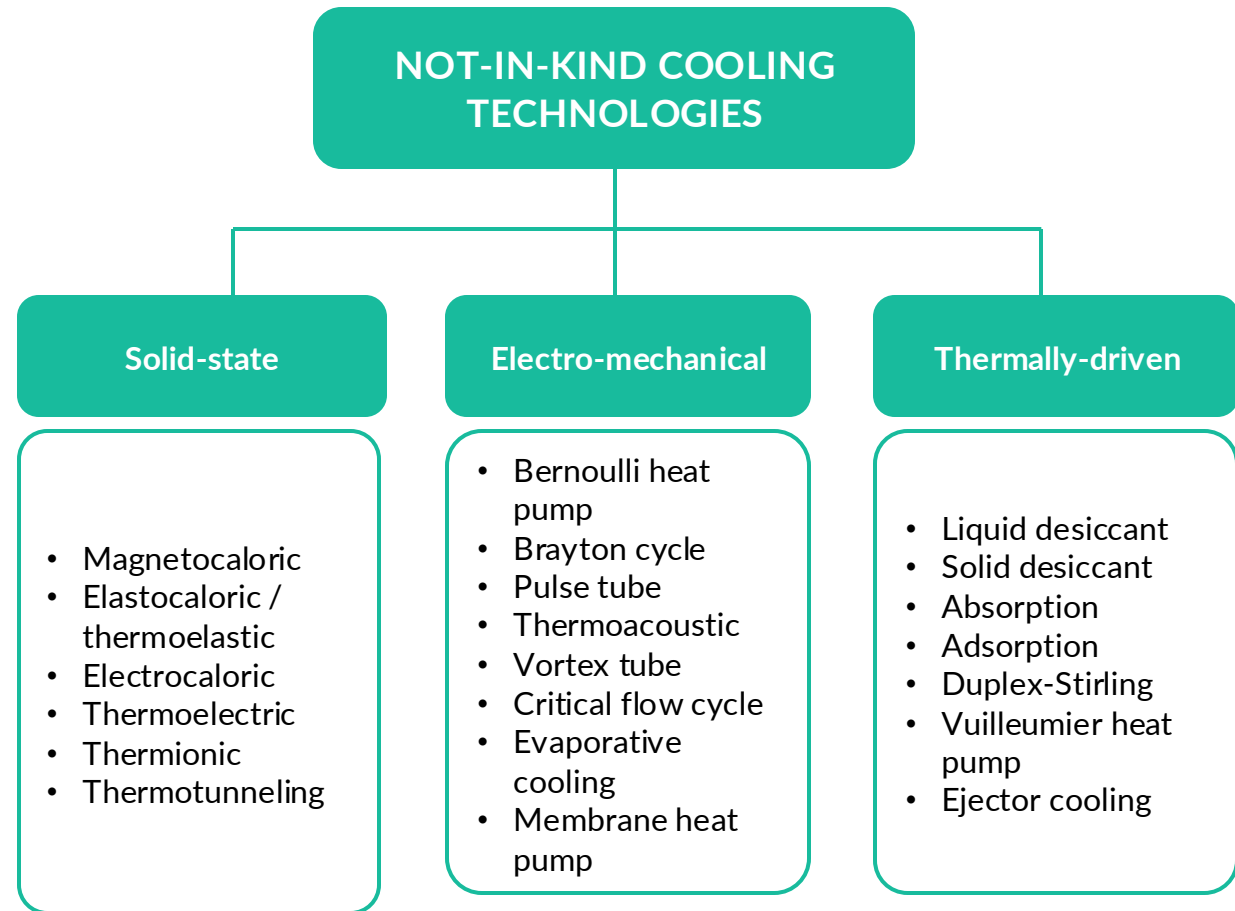

Source: Khosla et al., 2022

# NOT-IN-KIND TECHNOLOGIES

## Evaporative cooling

Evaporative cooling operates on thermal energy and water is used as a refrigerant. Water is evaporated in non-saturated air to produce a drop in dry bulb temperature and an associated rise in moisture content. It only works efficiently when the air to be cooled is relatively dry. There can be considerable water consumption

### Direct evaporative cooling

The ventilation supply air is passed directly through a water spray before entering the space to be cooled

### Indirect evaporative cooling

The ventilation supply air is passed through an evaporative heat exchanger, to be indirectly cooled. Unlike direct evaporative cooling, cooling of the supply air takes place without it absorbing extra moisture. However, the cooling efficiency is reduced

### Indirect-direct evaporative cooling

Here, direct cooling follows indirect cooling. The intention is to maximize cooling potential while minimizing the increase in moisture absorption of the supply air

Source: International Energy Agency, 2000

# NOT-IN-KIND TECHNOLOGIES

## Evaporative cooling

Direct evaporative cooling

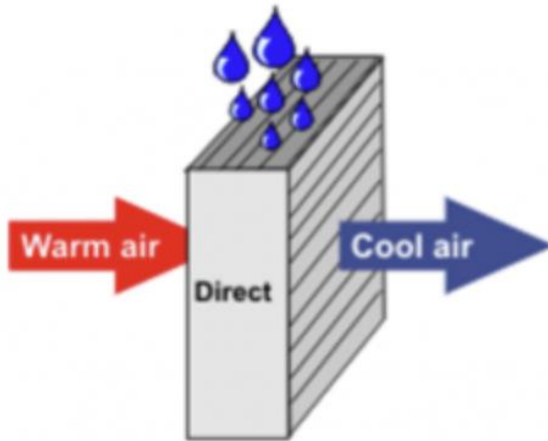

Indirect evaporative cooling

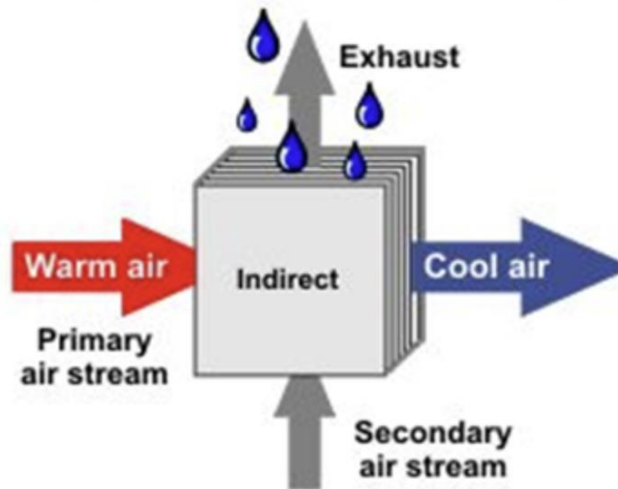

Indirect-direct evaporative cooling

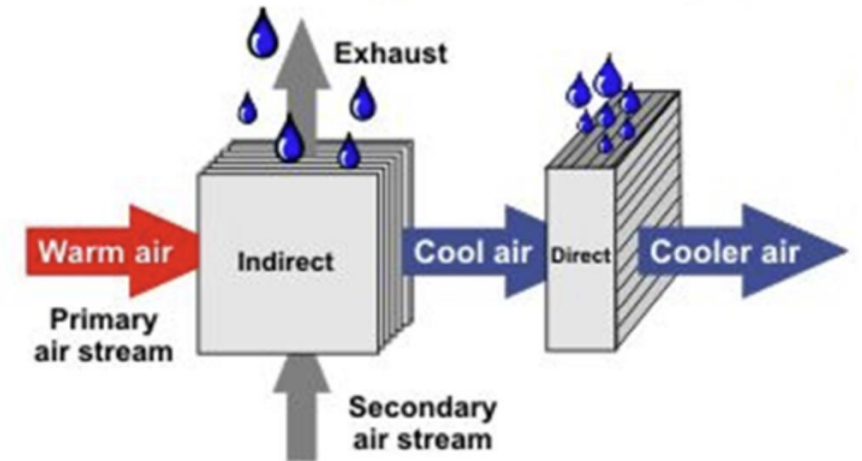

Source: Fairconditioning

# NOT-IN-KIND TECHNOLOGIES

## Evaporative cooling: Major applications

- Comfort cooling of commercial and institutional buildings
- Data center cooling
- Environmental control for processed food industry
- Provision of treated fresh air required in pharma and healthcare industry
- Animal house ventilation
- Industrial buildings, shop floors, warehouses etc.

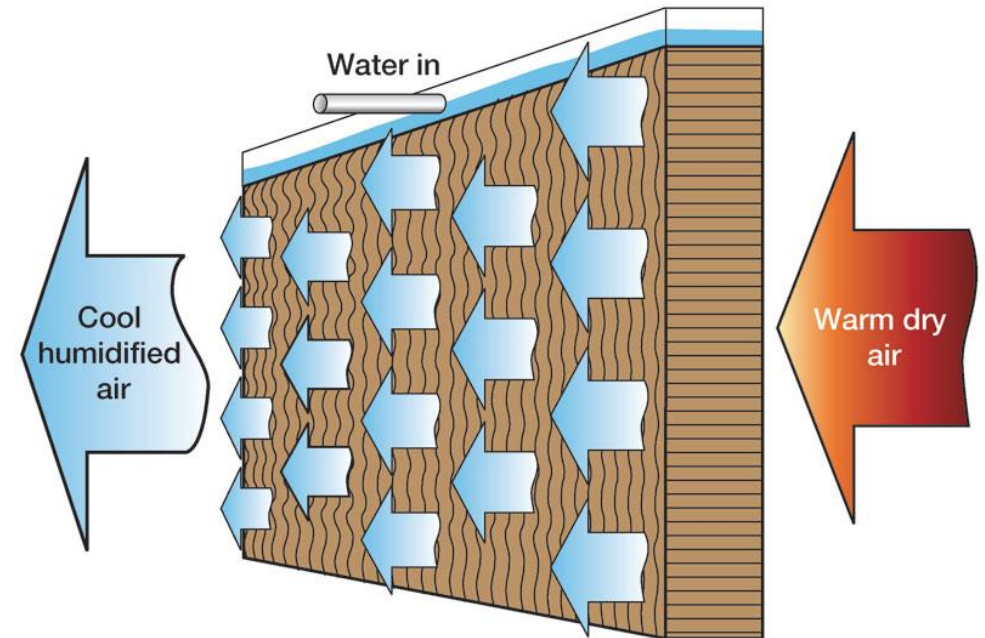

Image source: <https://www.condairgroup.com/Energy-optimization/cool-humidification-evaporative-cooling-humidifier>

# NOT-IN-KIND TECHNOLOGIES

## Case example: Evaporative cooling

### Central University of Rajasthan, India

- Indirect-direct evaporative cooling system is used
- Indoor temperatures were between 31°C and 34°C when the ambient was approximately 44°C
- Energy consumption in the hostel building was reduced to one-third of a similar building with no major energy conservation measures and using conventional air conditioning systems
- The Energy Performance Index was 60–65 kWh/m<sup>2</sup>/year (2012)



Source: United States Agency for International Development, 2014

# NOT-IN-KIND TECHNOLOGIES

Case examples: Evaporative cooling



Industrial building, Jaipur, India



School (Classrooms), Jaipur, India



Hostel, Lucknow, India

Source: Evapoler

# NOT-IN-KIND TECHNOLOGIES

## Dew-point evaporative technology

- Evaporative cooling in its most common forms can cool air up to the ambient wet bulb temperatures
- Dew-point evaporative cooling, using a novel heat exchanger and flow path arrangement, has been seen to deliver un-humidified air below wet bulb temperatures consuming less water than direct evaporative cooling

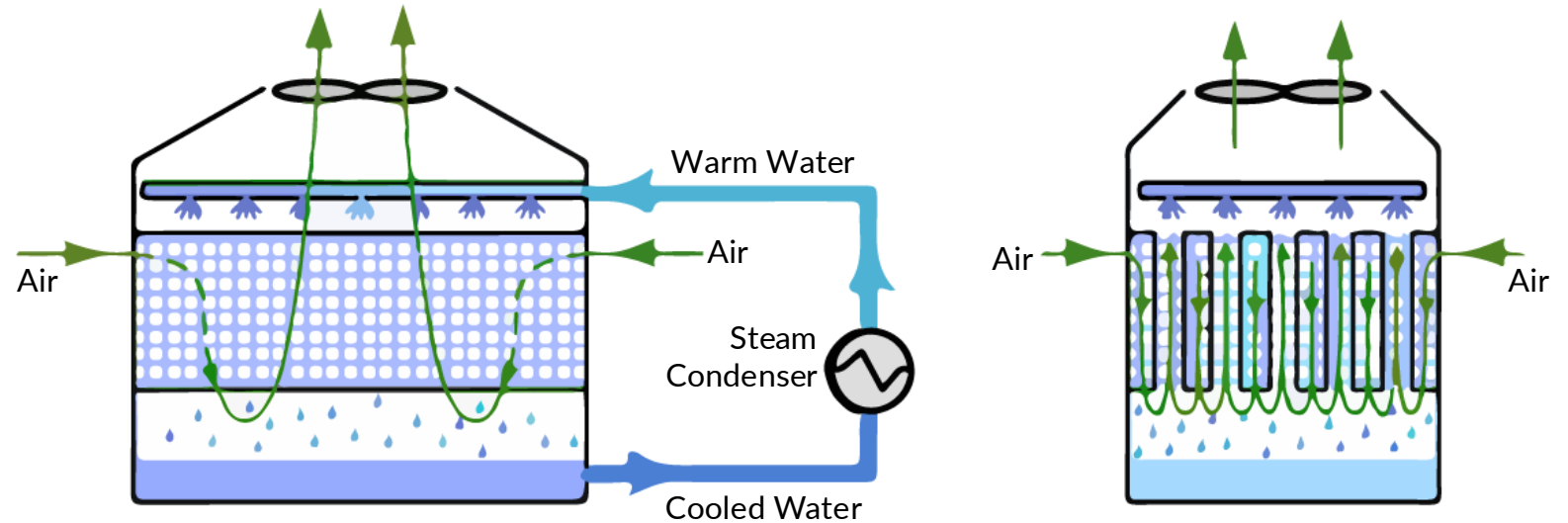

Advanced dew-point cooling tower concept

Source: Glanville, 2011

Image source:

[https://www.researchgate.net/figure/Advanced-Dew-Point-Cooling-Tower-Concept\\_fig1\\_269692837](https://www.researchgate.net/figure/Advanced-Dew-Point-Cooling-Tower-Concept_fig1_269692837)

# NOT-IN-KIND TECHNOLOGIES

## Structure cooling

- In a structure cooling system, the heat accumulated in the building structure is removed by water flowing through pipes embedded in the building structure, mostly the slabs
- Structure cooling uses water supplied at 20°C–27°C to the piping network embedded in the building slabs to remove the heat
- The objective is to prevent the build-up of heat in the building thermal mass during harsh summers in tropical climates, keeping it at temperatures lower than the body temperature of the occupants. The skin will lose heat to the cooler surroundings by radiation
- Cooling tower, storage water or geothermal sink may be used as the cold-water source



Image source:  
<https://www.attainablehome.com/what-is-radiant-floor-cooling-does-it-work/>

Sources: Yehuda, 2019; Solar Impulse Foundation

# NOT-IN-KIND TECHNOLOGIES

## Case example: Structure cooling

### Greenspace Realtors' Office, Nashik, India

- The system laid 21mm diameter plastic pipes in a grid on the slabs of all floors
- The system is designed to remove 763 W/m<sup>2</sup> of heat from the slabs
- The water absorbs the heat from the roof and flows through a radiator, where most of the heat is released
- Lukewarm water is stored in the tank and recycled through the radiator at night, when the cool night air absorbs the residual heat. The cycle starts again the next morning
- Energy for the pump and the fan is supplied by a solar PV system

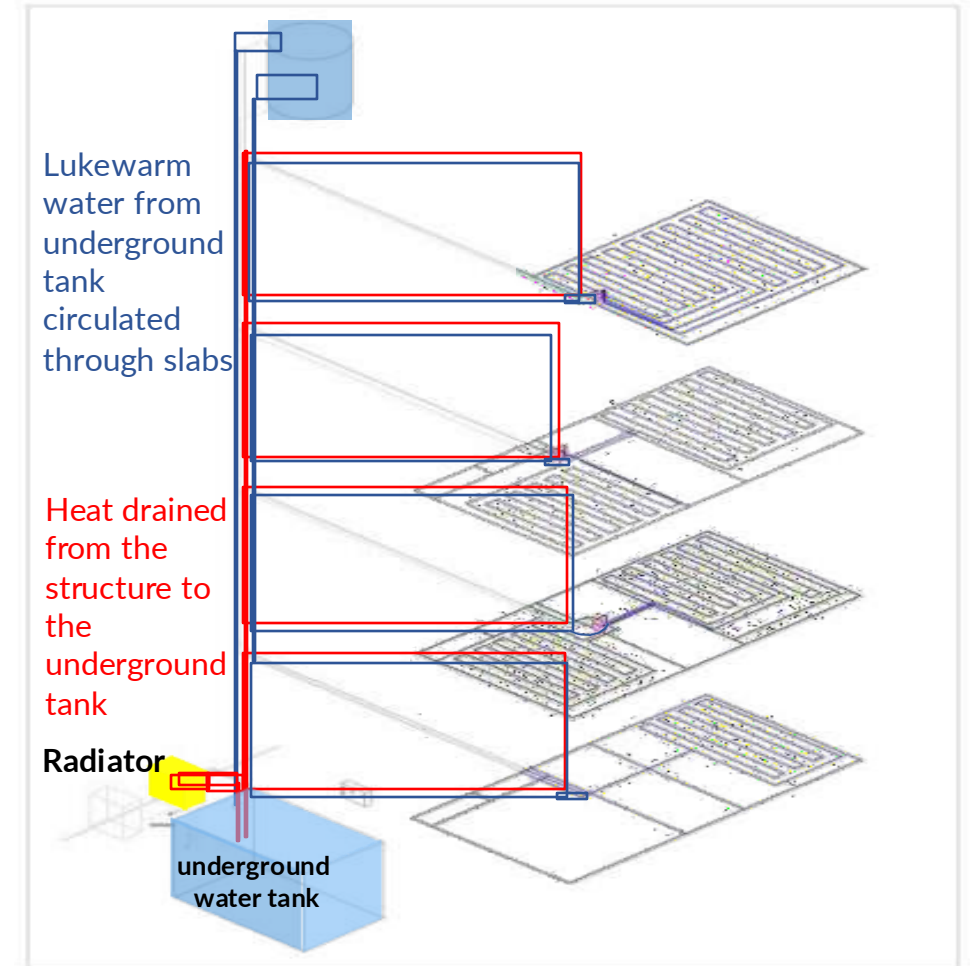

Structure cooling system installed in a office building at Nashik

Source: Yehuda, 2019

# NOT-IN-KIND TECHNOLOGIES

## Vapor absorption system

- Vapor absorption system produces chilled water for cooling using a heat source rather than electrical input as in the more familiar vapor compression cycle
- The vapor absorption cycle is similar to the vapor compression cycle in that it uses a circulating refrigerant, an evaporator, a condenser and an expansion device
- The difference is that the compressor of the vapor compression cycle is replaced by a chemical absorption process and generator, with a pump to provide the circulation and pressure change

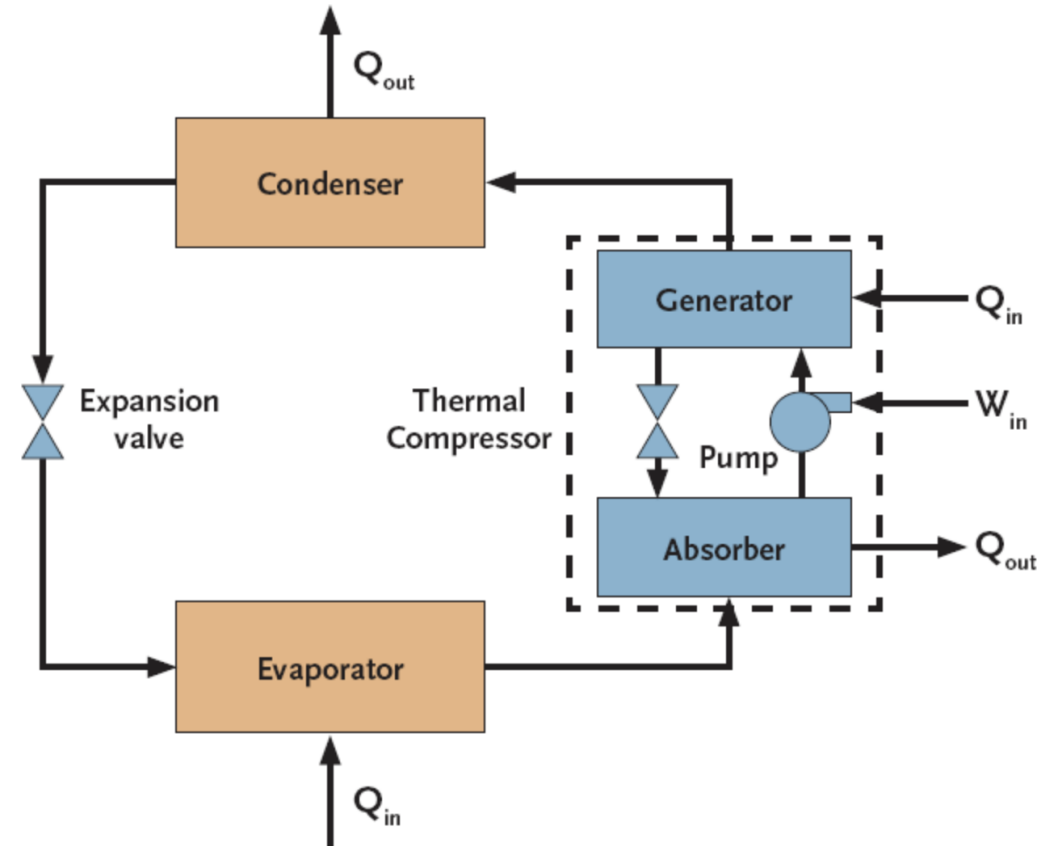

Basic absorption cycle

Sources: Welch, T. 2009; Bhatia, A.

# NOT-IN-KIND TECHNOLOGIES

## Comparison between vapor absorption system and vapor compression system

### Vapor Compression

- Uses a compressor to create the pressure rise between evaporator and condenser, which requires energy in the form of electrical energy
- Generally, uses refrigerants, like HFCs, with high environmental impact, ozone depletion or global warming potential
- Coefficient of performance (COP) of conventional compression chiller is sensitive to load variations and does not reduce significantly at part loads
- Has higher COP, but operating costs are higher
- Can be noisy and requires more maintenance

### Vapor Absorption

- Uses heat to operate the cycle. This opens up options for its application and use, including solar energy and waste heat
- Absorption cycle uses a liquid pump to create the pressure rise between evaporator and condenser
- Uses different refrigerants that have no associated environment hazard, ozone depletion or global warming potential, e.g. lithium bromide absorption system uses distilled water as the refrigerant
- COP of absorption chiller is not sensitive to load variations and does not reduce significantly at part loads
- Has lower COP, but operating costs can be substantially reduced because they are powered by low-grade waste heat
- Contains very few moving parts, has less noise and vibration, is compact for large capacities, and requires minimal maintenance

Source: Bhatia, A.

# NOT-IN-KIND TECHNOLOGIES

## Case example: Vapor absorption cooling

### Solar Energy Centre, Gurgaon, India

- Example of solar thermal cogeneration
- 100kW cooling capacity standalone system is integrated with a triple-effect vapor absorption chiller (VAC) and solar parabolic concentrators. The VAC can use steam, hot water, gas, kerosene or oil to run continuously
- The integrated system is estimated to be 20% more efficient than VACs with no solar component. COP is 1.7, which is highest among the vapor absorption technology coupled with eco-friendly energy resource



Source: United States Agency for International Development, 2014

# NOT-IN-KIND TECHNOLOGIES

Case example: Vapor absorption cooling

## GAIL Jubilee Tower, Noida, India

- Example of cogeneration facility to generate power and cooling
- **440 TR (220 TR X 2) of vapor absorption cooling**
- Heat source is hot water from waste heat of 1.6 MW (800 kW X 2 cumulative capacity) engines exhaust, with optional direct gas firing, if required



Source: Net Zero Energy Buildings

# HYBRID SYSTEMS

Integrating not-in-kind technologies with vapor compression systems and other technologies

- The not-in-kind options can be integrated with conventional vapor compression systems to derive benefits of multiple technologies
- Heat/energy recovery technologies such as energy recovery ventilators (residential) or heat pipes, run-around coils or enthalpy wheels (commercial), when included in a cooling system, can help recover energy that would otherwise be wasted

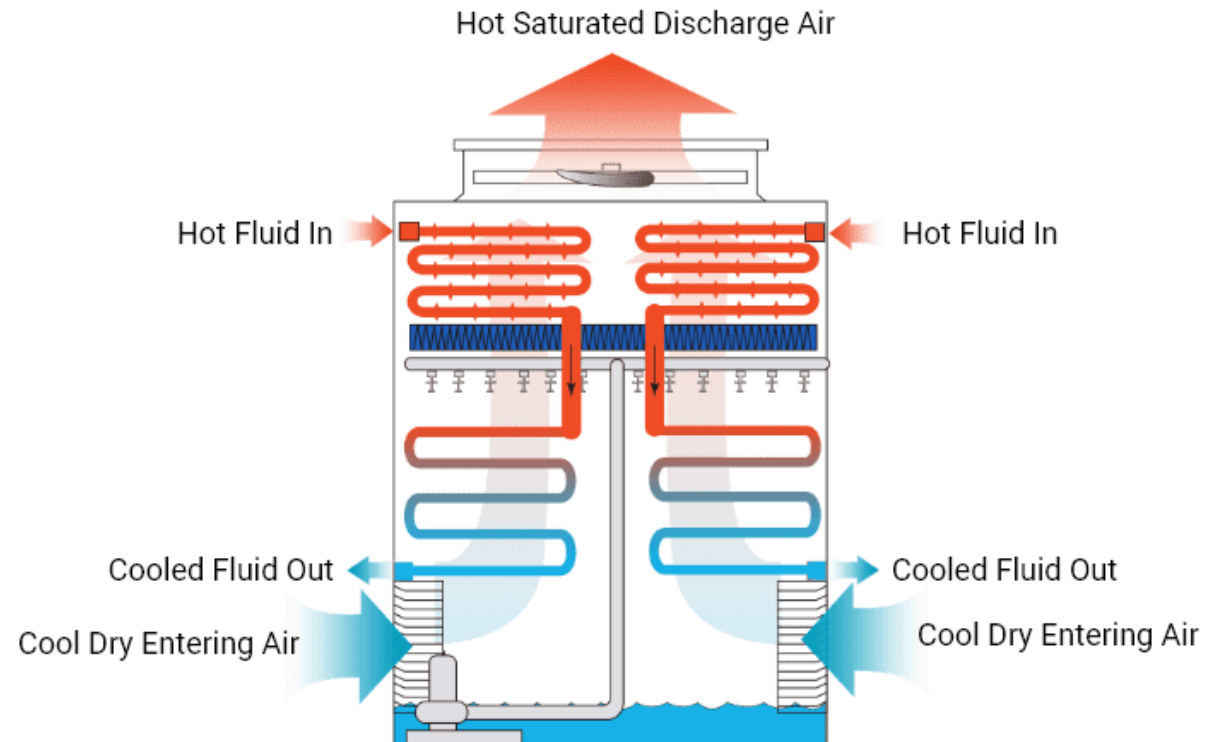

Source: Ministry of Environment, Forest and Climate Change, Government of India, 2019

Image source: <https://www.flycoolingtower.com/products/hybrid-wet-dry-cooling-tower/index.html>

# HYBRID SYSTEMS

## Radiant cooling

- Heat transfer to the space being cooled in conventional chiller-based air conditioning happens through convection. In a radiant cooling system, heat transfer happens through radiation
- Radiant cooling systems consist of coils, which carry chilled water generated either through conventional electric chiller (vapor compression) systems or low-energy chilled water generation systems like absorption chillers or desiccant chillers. Chilled water in the coils cools down the slabs or panels, which in turn act as heat sinks for sensible heat loads of internal spaces
- Condensation in humid conditions is a risk in these systems. An ancillary dedicated outdoor air system (DOAS) is required to avoid condensation

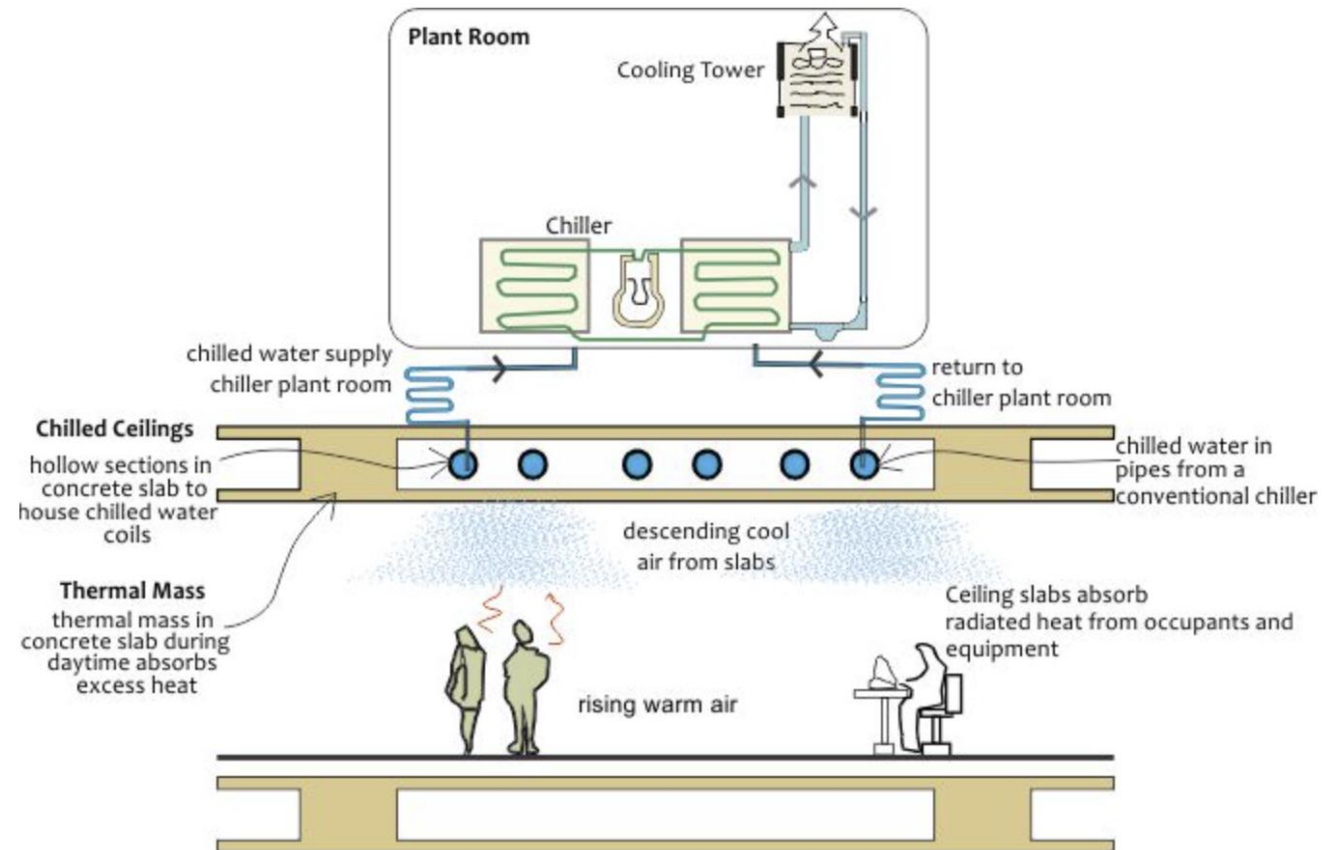

Source: United States Agency for International Development, 2014

Image source: <https://pillarplus.com/radiant-cooling-system/>

# HYBRID SYSTEMS

## Radiant cooling: Types

- **Chilled slabs:** Deliver cooling through the building structure, usually slab. Generally, cheaper than panel systems and offer the advantage of the thermal mass
- **Ceiling panels:** Deliver cooling through specialized panels. Offer faster temperature control and flexibility

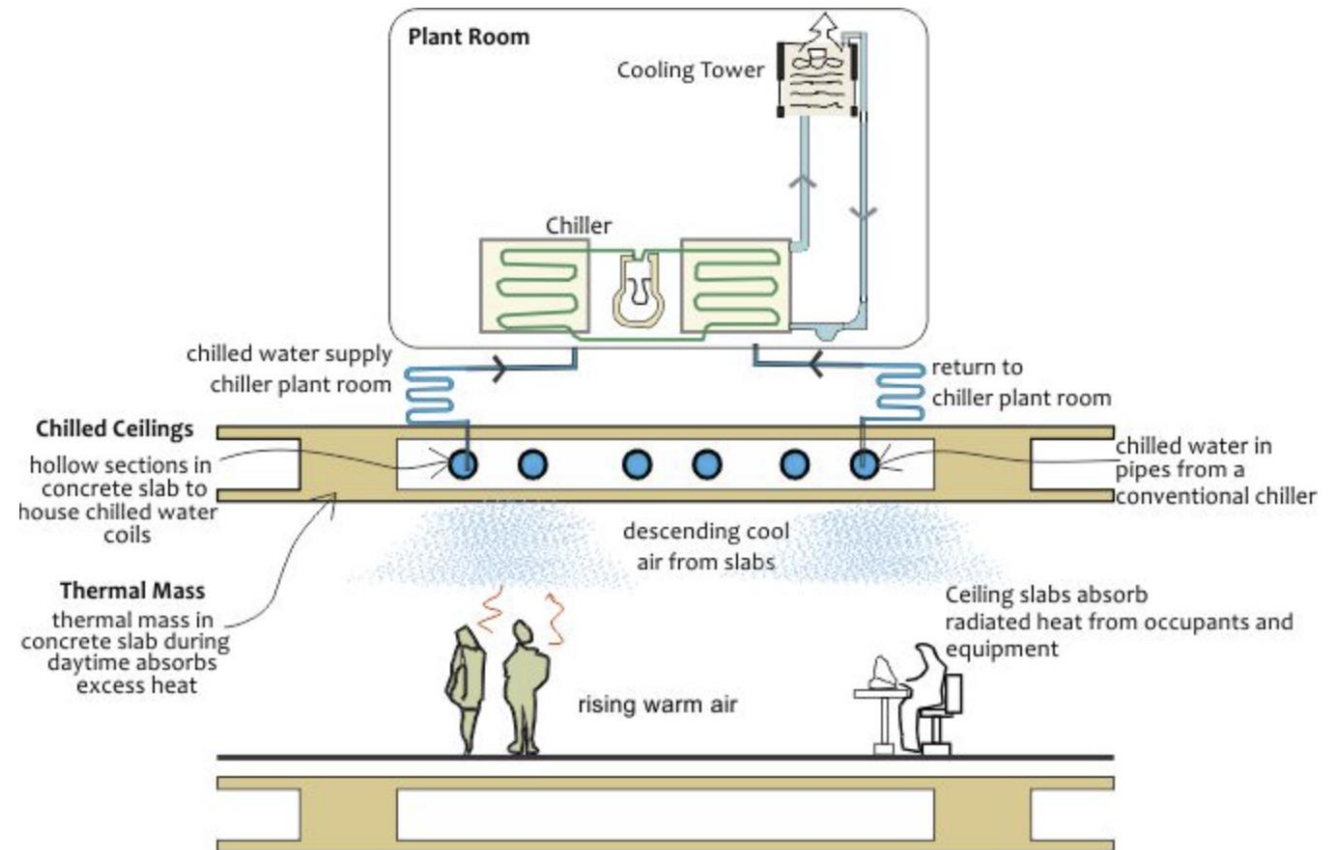

Source: United States Agency for International Development. 2014

Image source: <https://nzeb.in/knowledge-centre/hvac-2/radiant-cooling-systems/>

# HYBRID SYSTEMS

## Case example: Radiant cooling

### Infosys Software Development Building (SDB-1), Hyderabad, India

- The two symmetric halves of the buildings are cooled with different technologies. Conventional cooling system in one half, radiant cooling system in the other
- The radiant system is designed for a cooling output of 75 W/m<sup>2</sup>
- Chilled water design temperatures for supply are 14°C and for return, 17°C
- Cooling tower approach temperature is 2°C
- Low-pressure piping and ducting distribution system is installed
- A DOAS with energy recovery system is installed to provide dehumidified air to offices



Cooling energy use  
for conventional  
system (2011–2012)

38.7 kWh/m<sup>2</sup>

Cooling energy use  
for radiant system  
(2011–2012)

25.7 kWh/m<sup>2</sup>

33% improvement in  
energy efficiency with  
radiant cooling system

# HYBRID COOLING

Case example: Conventional air conditioning, fresh air dehumidification and evaporative cooling

## Centre Point School, Nagpur, India

- Cooling mode switches between conventional chillers and evaporative cooling system, depending on the ambient temperature and humidity
- During operation of the conventional chillers, the treated fresh air (TFA) unit ensures adequate moisture removal from fresh air, permitting operation of the air conditioning at higher temperature setting
- During cool and dry ambient weather, chillers can be switched off, and chilled water is substituted by 'cold' cooling water from the cooling tower, thus, almost achieving 'free cooling', with minimal cooling tower fan power



Source: Centre Point School, Nagpur, India

# HYBRID COOLING

Case example: Conventional air conditioning, fresh air dehumidification and evaporative cooling (continued)

## Centre Point School, Nagpur, India

- Indirect adiabatic two-stage evaporative cooling, in addition to free cooling by direct use of outside cold air during favorable outdoor air temperatures to provide partial space cooling requirements
- During night, the strategy is to have the cool night air pass over the exposed interior surfaces to keep the surfaces cool at night
- All classrooms have three-speed fan coil units (with water coils) with controls for room temperature and humidity
- High efficiency, variable speed BLDC fans are used for room air circulation, for enhancement of thermal comfort, while operating chillers at higher chilled water temperatures



Source: Centre Point School, Nagpur, India

# HYBRID COOLING

Case example: Vapor absorption cooling and liquid desiccant dehumidification

## Chhatrapati Shivaji Maharaj Hospital, Thane, India

- The waiting area of the Out-Patients Department (OPD) has very high occupancy and is open from the sides
- A liquid desiccant dehumidification system (LDDS), along with a cooling tower, provides ‘once-through’ 100% fresh air at 26°C, at a dew point of 15°C, for adaptive cooling of the OPD waiting area, with chilled water generated by VAM

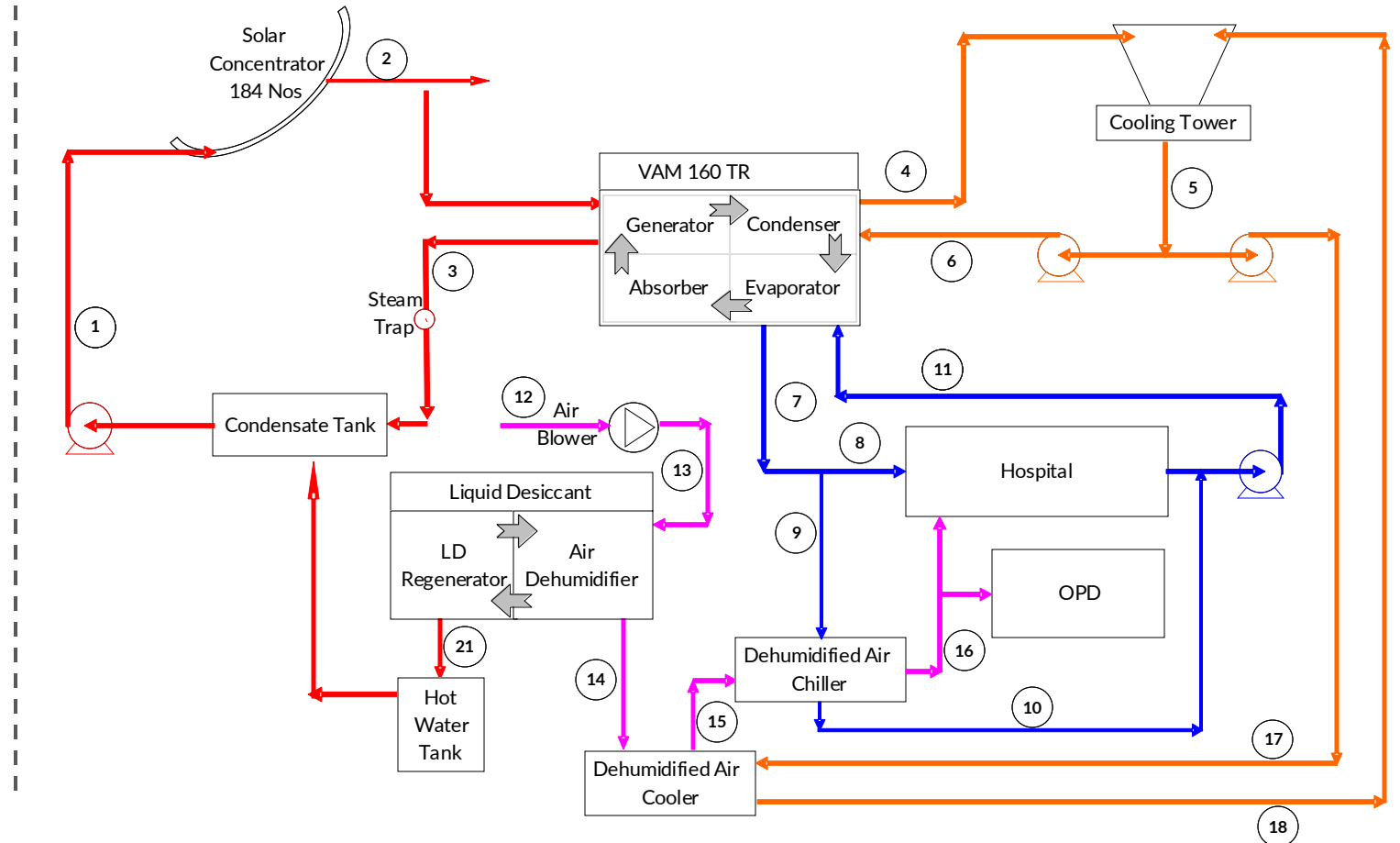

Source: Chhatrapati Shivaji Maharaj Hospital, Thane, India

# HYBRID COOLING

Case example: Vapor absorption cooling and liquid desiccant dehumidification (continued)

Chhatrapati Shivaji Maharaj Hospital, Thane, India

- Scheffler solar thermal concentrators have been installed to provide steam and hot water for regeneration of liquid desiccant and heat source for the absorption chiller
- The solar-heated absorption chiller has a cooling capacity of 160 TR, which provides cooling to other areas of the hospital
- This system has substituted electrical chillers and LDO-fired boilers



Liquid desiccant dehumidification system



Scheffler solar thermal concentrators

Source: Chhatrapati Shivaji Maharaj Hospital, Thane, India

# NOT-IN-KIND TECHNOLOGIES

Case example: Tri-generation with vapor absorption cooling system

## Pushpanjali Crosslay Hospital, Ghaziabad, India

- Tri-generation systems are combined heat and power (CHP) systems integrated with a thermally-driven refrigeration system to provide cooling, as well as generate electrical power and heating
- The tri-generation system provides 1,000 TR cooling for air conditioning
- The system components to provide heating and cooling include a gas genset (1.7 MW), 600 TR capacity vapor absorption machines (VAM) with heat recovery, and electrical chillers of 400 TR capacity



Source: Net Zero Energy Buildings

# ALTERNATIVE COOLING STRATEGIES

## Thermal energy storage and tri-generation

### Thermal energy storage

Thermal energy storage is a method of demand-side load management and must be integrated with cooling technologies. It can significantly reduce energy costs by allowing cooling equipment to be predominantly operated during off-peak hours (favorable electricity tariff periods). Ice banks, cryogenic liquids, phase change materials (PCMs) may be used as the storage medium

### Tri-generation

Tri-generation can be used where there is a simultaneous demand for heat and power and uninterrupted availability of fuel. Advantages include: (i) onsite generation of electricity, heat and power; (ii) maximum total fuel efficiency; (iii) reduced fuel and energy costs; (iv) lower electrical demand during peak time; (v) elimination of HCFC/CFC refrigerants; and (vi) emissions reduction

**Most vapor absorption cooling applications include tri-generation (heat, cooling and power) or co-generation (heat and power) systems**

Source: Ministry of Environment, Forest and Climate Change, Government of India, 2019

# ALTERNATIVE COOLING STRATEGIES

## District cooling

- District cooling systems provide cooling to an entire community from a network of centralized cooling devices. They supply chilled water produced in a central plant to buildings and industrial sites through a network of insulated pipes

### Advantages

- Buildings do not require their own air conditioning systems, saving space and reducing the need to have surplus cooling capacity for peak loads
- Lower costs due to economies of scale, especially if it makes use of a low-cost source of energy, such as industrial waste, excess heat or geothermal energy

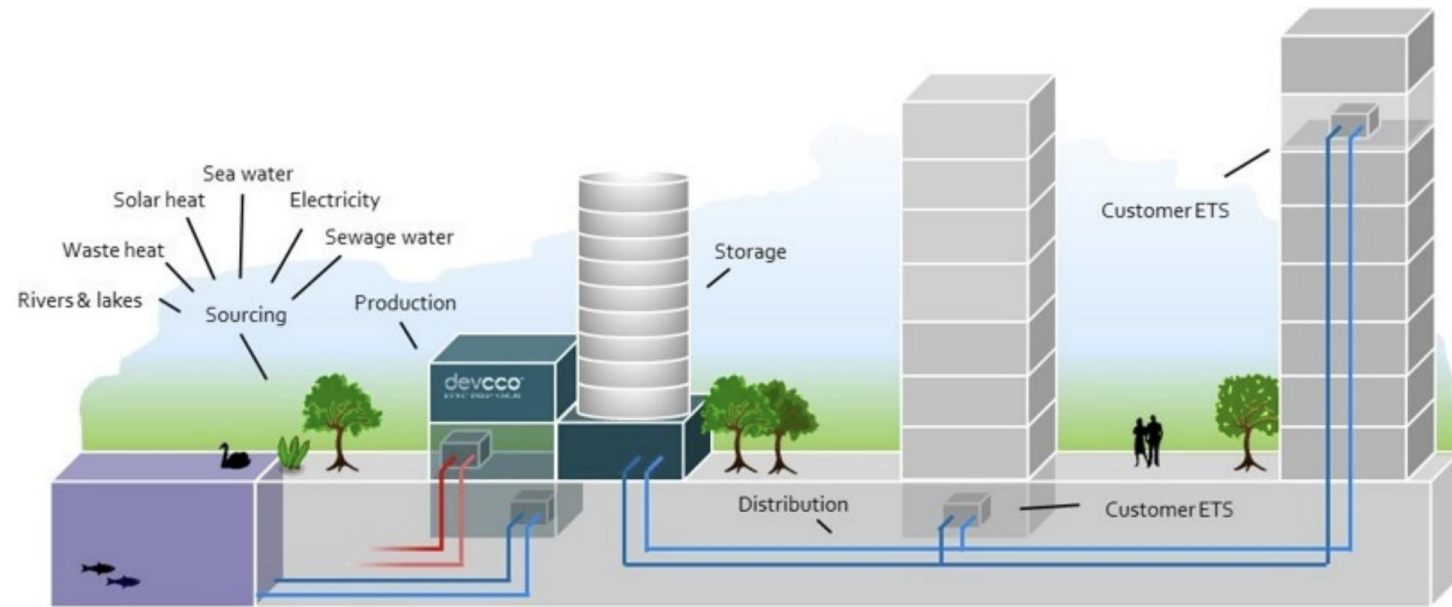

General scheme of a district cooling system

Sources: International Energy Agency, 2018; Calderoni et al., 2019

# ALTERNATIVE COOLING STRATEGIES

## District cooling

- The chilled water is typically produced using the same technology i.e., vapor compression system but generally at a much larger scale
- In some locations, the water may be chilled in part or in full using heat exchange with natural sources, such as groundwater, rivers and the sea, if environmental conditions and costs permit. Waste heat from industries, geothermal or even solar thermal sources, can also be used with absorption chillers
- District cooling systems often incorporate storage in the form of cold water, slurry or ice, to reserve cooling energy during low load periods to:
  - Reduce the need for extra capacity during peak loads
  - Minimize the partial load operation and maximize operation near full load to improve energy efficiency
  - Allow for flexibility to produce more cooling than required when electricity prices are low

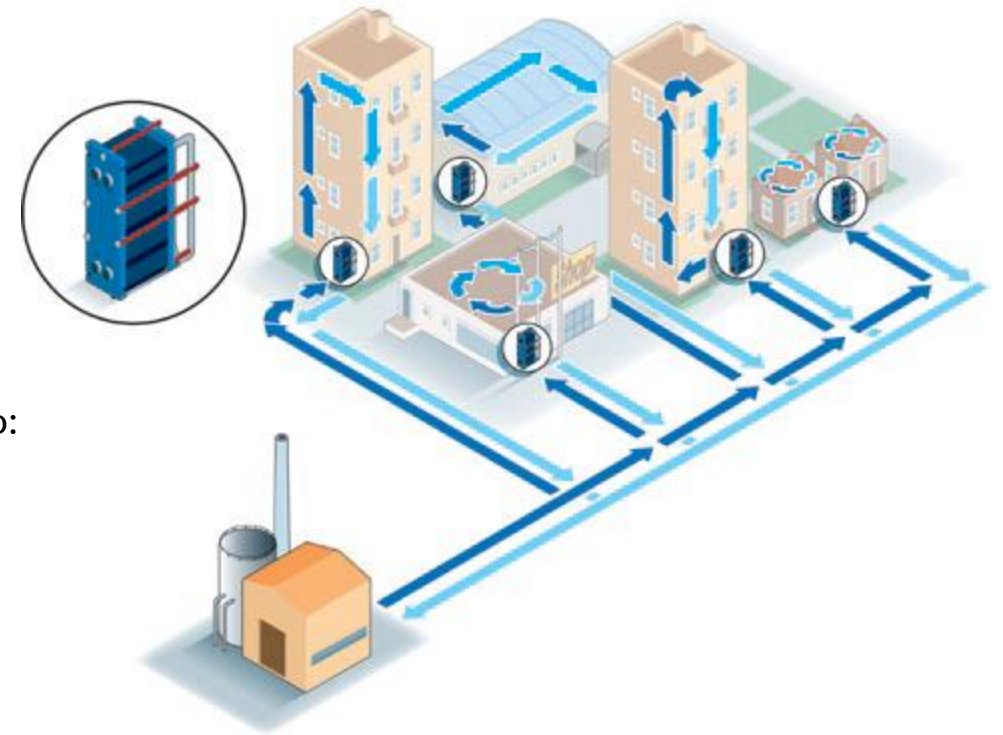

Image source: <https://www.alfalaval.my/industries/hvac/district-cooling/what-is-district-cooling-system/>

# ALTERNATIVE COOLING STRATEGIES

## Case example: District cooling

### GIFT City, Gandhinagar, India

- Consists of office buildings, residential apartments, schools, a hospital, hotels, retail stores and recreational facilities
- When fully built, it will reduce the requirement for installed cooling capacity from 270,000 TR to 180,000 TR. It is expected to reduce the cooling power demand of the city, as compared to business as usual, by 105 MW of electricity
- The system will use low GWP refrigerant for cooling generation and include stratified thermal energy storage tanks that are used to meet the cooling loads during peak demand periods, reducing total power demand of the system



Sources: United Nations Environment Programme, 2021a; GIFT City

# ALTERNATIVE COOLING STRATEGIES

## Case example: District cooling

### Paris, France

- It is the largest district cooling network in Europe, serving offices, banks, stores, hotels, museums and other buildings
- Leverages the Seine River as an available heat sink in 3 of its 10 production sites. When the water temperature is below 8°C, water from the Seine is distributed directly through these sites as free cooling
- During the night, when the demand for cooling is lower, it takes advantage of off-peak electricity and stores thermal energy as either chilled water or ice, which is then used during the hours of peak demand during the day. This storage has the potential to decrease peak power for cooling by 15%–50%
- Nearly 60% of the chilled water distribution system is routed through the city's sewage network

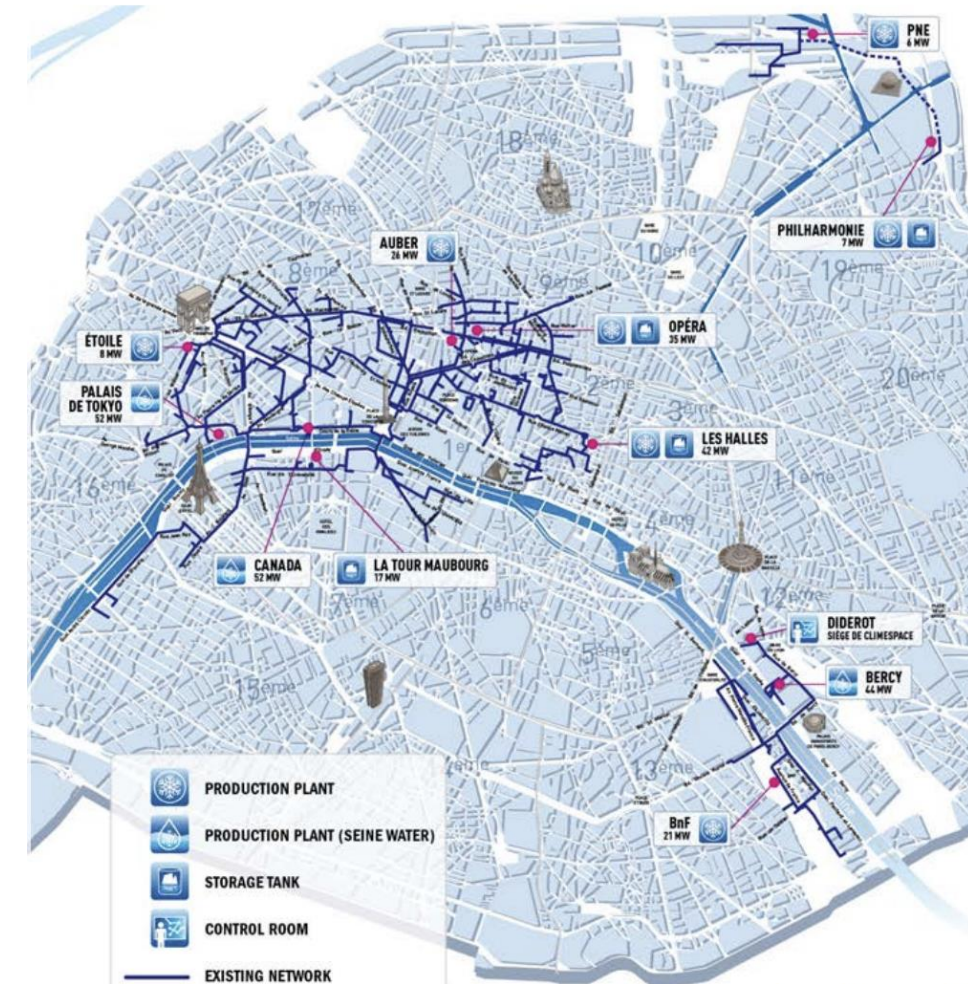

District cooling network in Paris

Sources: United Nations Environment Programme, 2017 and 2021a

# Sustainable Cooling

Refrigerants



Image source: <https://bootes.in/radiant-cooling/>

# REFRIGERANTS

The story so far .....

Early refrigeration technology

Refrigerants were flammable or toxic, confining their use mainly to industrial systems

Refrigerants for space cooling

Safer refrigerants, based on chlorofluorocarbons (CFCs) and hydrochlorofluorocarbons (HCFCs), were developed

Montreal Protocol 1987

This protocol mandated the phase out of CFCs and HCFCs due to their high ozone depletion potential (ODP). They were mainly replaced by hydrofluorocarbon (HFC)-based refrigerants with short-lived gases that have no ODP

Kigali Amendment to Montreal Protocol 2016

The GWP of HFCs is still high, ranging between 1,340  $GWP_{100}$  for R134a and 3,940  $GWP_{100}$  for R404a. The Kigali Amendment to the Montreal Protocol was initiated to phase down these high-GWP HFCs

Source: Khosla et al., 2022

# REFRIGERANTS

## Alternatives

Low-ODP and low-GWP refrigerants will need to balance the trade-offs between energy efficiency, safety, cost, availability, and environmental considerations of new refrigerants. Examples of alternative refrigerants are:

### Hydrofluoroolefins (HFOs)

- HFOs have  $GWP_{100}$  values of less than 1
- But they typically still need to be mixed, e.g., with HFCs, to obtain a non-flammable blend or for direct substitution in existing equipment, which results in higher GWP

### Natural refrigerants

- Use of natural refrigerants, such as ammonia and hydrocarbons, are commonplace in industrial systems where large equipment sizes are common, and flammability and toxicity can be more readily managed
- Their use in residential space cooling is debatable due to smaller sizes, life cycle emissions and need for increased safety measures

Source: Khosla et al., 2022

# ALTERNATIVE REFRIGERANTS

## Current space cooling applications

### Vapor absorption systems

- Refrigerants used are ammonia (0 GWP<sub>100</sub>) and water
- Used for comfort cooling in commercial and industrial buildings and process cooling

### HC 290 air conditioners

- Hydrocarbon-based cooling system
- Refrigerant used is HC 290 (5 GWP<sub>100</sub>), which is flammable
- Available for residential and commercial air conditioning

### Solar-assisted cooling

- Solar-assisted vapor absorption cooling
- Refrigerants used are ammonia (0 GWP<sub>100</sub>) and water
- Applicable for cluster air conditioning

Source: iForest, 2021

# ALTERNATIVE REFRIGERANTS

## Challenges in adoption

### Lack of awareness

Decision-making on residential air conditioner purchase are not based on the refrigerant gas. In the absence of substantive awareness efforts on natural refrigerants, HFC-based air conditioners continue to be the mainstream choice

### High cost

Natural refrigerant systems are found to have a high initial cost, due to small manufacturing capacity for these technologies and scarcity of expertise both in terms of technical experts and servicing technicians

### Difficulty with retrofitting

Large number of existing equipment like chillers, VRF and packaged DX may not be suitable for retrofitting with natural refrigerant-based systems

### Safety and lack of standards

Concerns around safety of natural and low-GWP refrigerants remain. Standards for system design and refrigerants become imperative for safety

Source: iForest, 2021

# Sustainable Cooling

Services, Policies and Financial Solutions



# SUSTAINABLE COOLING

## Services solutions

### Preparational services

- Activities that support the preparation (e.g., theory and practical skills) to create or deploy more sustainable cooling solutions
- Includes fundamental education, skills development and project services

### Operational services

- Activities to deliver and use more sustainable cooling
- Includes direct operation of cooling services, the management that supports cooling services, and the maintenance that ensures the cooling services and technologies are operating sustainably

Source: Sustainable Energy for All, 2020

# SUSTAINABLE COOLING

## Policy solutions

### Regulatory policies

Legally binding or 'stick' measures:

- Building energy codes
- Planning and zoning codes
- Minimum energy performance standards (MEPS)
- Disclosures through labels and certificates
- Audits and evaluations
- Utility obligations
- Public procurement requirements
- Import and export controls

### Information policies

Awareness generation measures:

- Disclosures through public databases
- Certification of education, product or service
- Labels for branding, endorsement and comparison
- Voluntary standards
- Awareness through information and behavior campaigns

### Incentive policies

Motivational or 'carrot' measures:

- Non-financial incentives such as expedited approval and expanded scope allowance
- Policies to deliver financial solutions

Source: Sustainable Energy for All, 2020

# SUSTAINABLE COOLING

## Financial support

### Finance solutions

- Loans
- Risk sharing
- Energy performance contracts or service agreements
- Bulk purchases
- Leasing
- On-bill or on-tax repayment
- Equity
- Bonds
- Sustainable or energy investment funds
- Crowdsourcing

### Fiscal solutions

- Energy pricing and subsidies
- Energy or carbon tax on unsustainable systems
- Tax credits on more sustainable solutions
- Import and export duties (reduced for sustainable solutions)

### Funding solutions

- Grants: Direct financial contribution
- Rebates: Direct financial contribution as a result of purchasing a product or service
- Subsidy: Direct financial contribution to reduce cost of product or service

Source: Sustainable Energy for All, 2020

# Thank you!

For more information, visit us at <https://ALCBT.GGGI.ORG>  
or scan the QR code below



## IKI Independent Complaint Mechanism

Any person who believes they may be harmed by an IKI project or who wish to report corruption or the misuse of funds, can lodge a complaint to the IKI Independent Complaint Mechanism at [IKI-complaints@z-u-g.org](mailto:IKI-complaints@z-u-g.org). The IKI complaint mechanism has a panel of independent experts who will investigate the complaint. In the course of the investigation, we will consult with the complainant so as to avoid unnecessary risks for the complainant. More information can be found at <https://www.international-climate-initiative.com/en/about-iki/values-responsibility/independent-complaint-mechanism/>.

 [www.gggi.org](http://www.gggi.org)

 [@gggi\\_hq](https://twitter.com/gggi_hq)

 [@GGGIHQ](https://www.instagram.com/GGGIHQ)

 [@GGGIHQ](https://www.facebook.com/GGGIHQ)

 [@gggi\\_hq](https://www.linkedin.com/company/gggi-hq)

 [@GGGIMedia](https://www.youtube.com/GGGIMedia)



Supported by:



on the basis of a decision  
by the German Bundestag



# 2.5 Operational Energy – Opportunities for Optimization

November 2024



Supported by:



on the basis of a decision by the German Bundestag

# WHAT WILL YOU LEARN?

Approach for  
Operational  
Energy Reduction

01

Operational  
Energy Reduction  
in HVAC

02

Operational  
Energy Reduction  
in Lighting

03

Operational  
Energy Reduction  
in Other Services

04

Integration of  
Renewable Energy

05



# OPERATIONAL ENERGY REDUCTION

First step: Minimize energy requirement by adopting passive measures

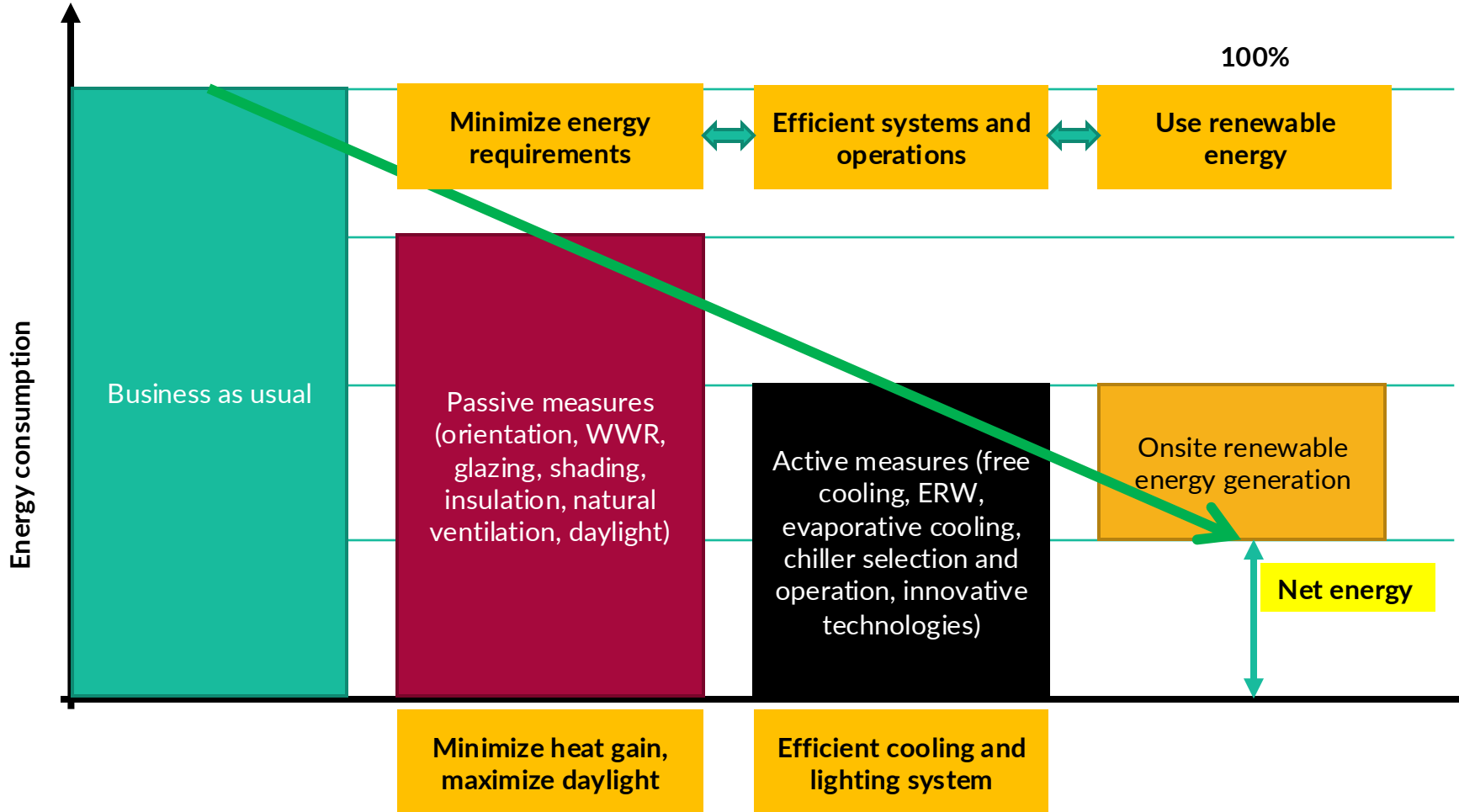

- First, reduce energy requirement of the building using passive measures
- Integrated design process is imperative to achieve operational energy goals

# Operational Energy Reduction in HVAC

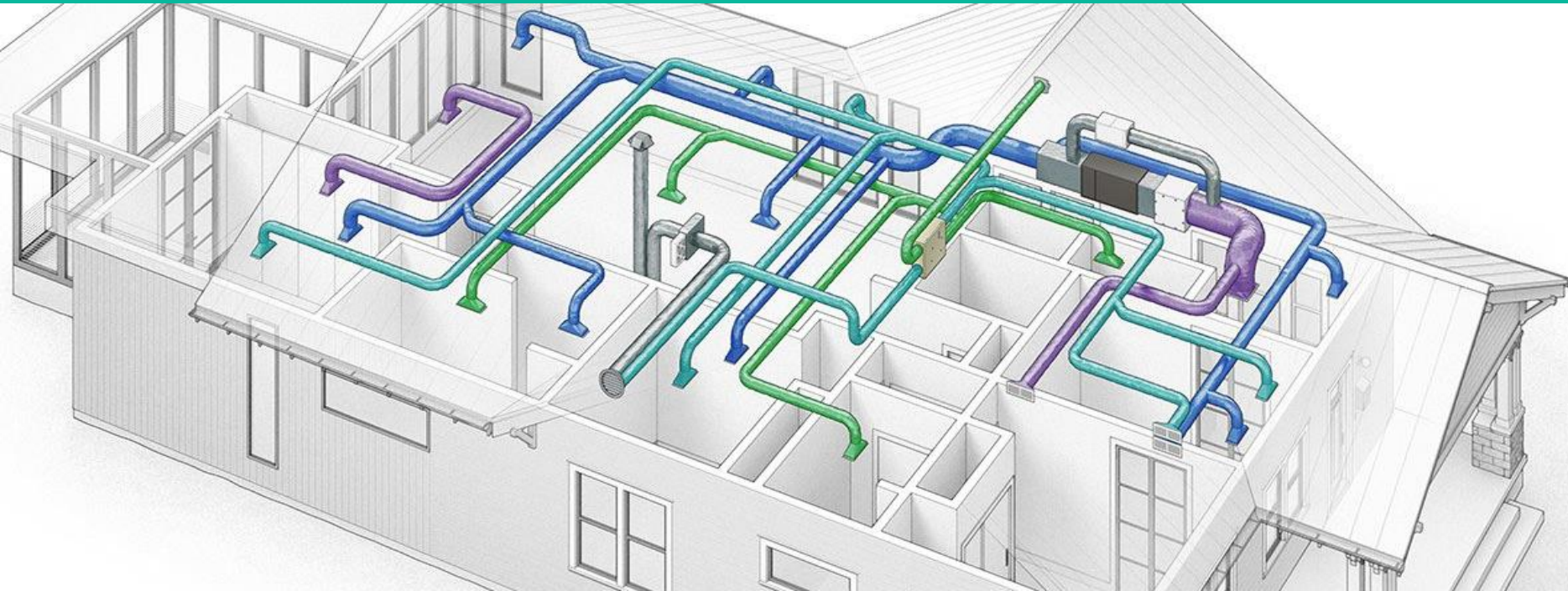

# SIZING THE HVAC SYSTEM

## Factors for optimization

Depends on several factors:

- Ambient conditions (temperature, humidity, solar radiation, wind)
- Internal conditions (stringent setpoints, adaptive comfort)
- Building usage and internal loads (occupants, lighting loads, equipment loads)
- Building envelope (wall, window, roof) and its properties (passive measures that helps in load or required size reduction)

**Do not consider only the worst possible scenario**

**Use calculation sheets and software tools to size the system optimally**



Target kW/TR of cooling?

# HVAC: LIFE CYCLE COSTING

Energy cost is the obvious focus area

Consider operational life of 15 years for equipment and systems

- The initial capex is about 10%
- Cost of operation and maintenance is 3%–5%
- Operating cost (energy consumed) is 85%–87%

Select systems and equipment with long-term perspective and not just initial cost

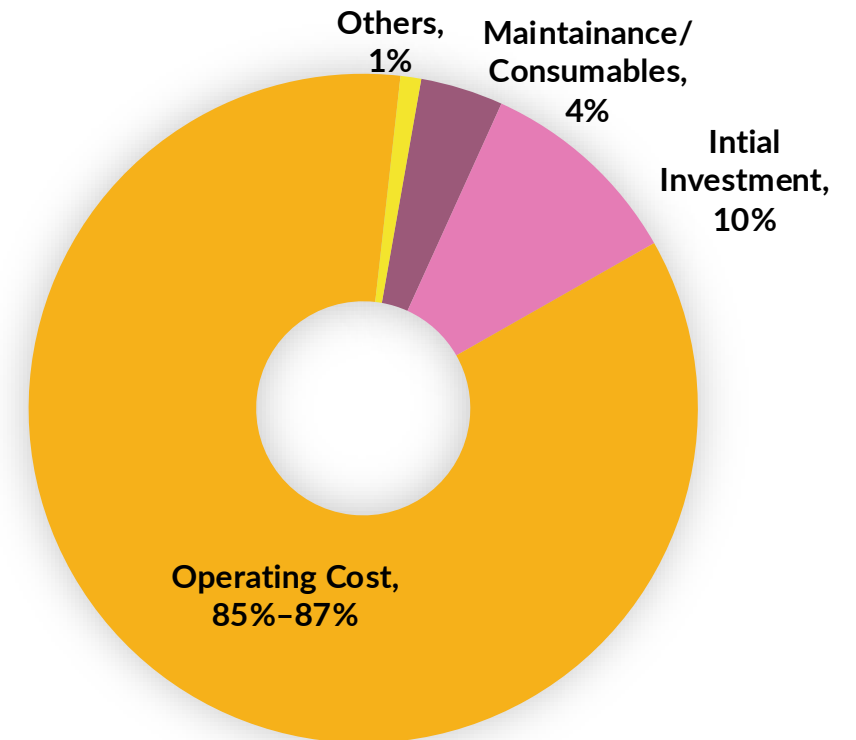

# SELECT EFFICIENT SYSTEMS

## Part-load performance is important

- Most equipment have a full-load minimum efficiency metric that is based on standard conditions at rated full-load
- When selecting system, it is important to check the part-load performance, which gives system efficiency at varying loads and operating conditions
- Some figures of merit for chillers are:
  - Integrated part-load value (IPLV)
  - Integrated energy efficiency ratio (IEER)
  - Seasonal energy efficiency ratio (SEER)
- Loads may vary significantly with climatic conditions and building utilization

**Select a system that gives better part-load performance in the most frequently operating load band**

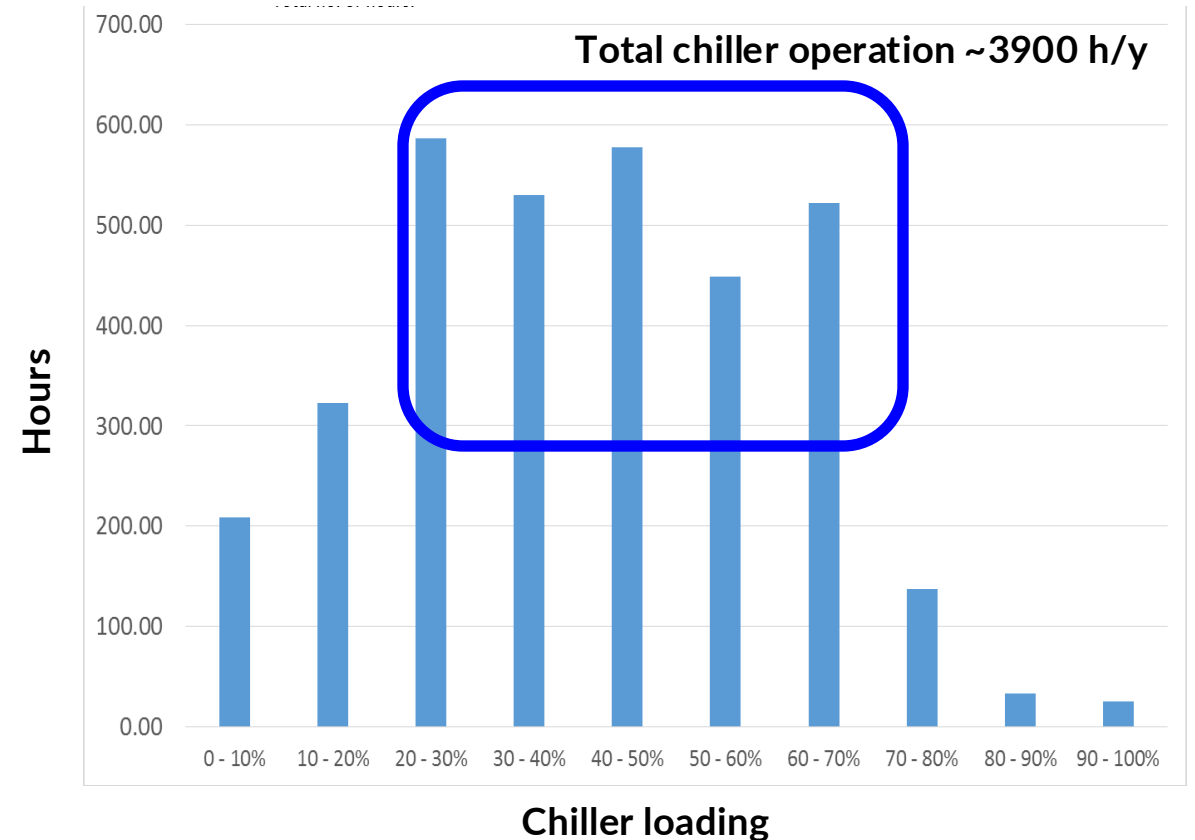

**Example: Load variations on a chiller**

# SYSTEM EFFICIENCY

## Guidance on minimum efficiency levels

- The system efficiency levels are prescribed at both international and national levels, and are updated at regular intervals
- Internationally, the minimum equipment efficiency values defined in **ASHRAE Standard 90.1** are well recognized and widely used. Meeting the prescriptions of the latest edition can ensure that selected systems will require lower operational energy
- At national levels, the local codes or standards will **supersede**; for example, in **India**, the **Energy Conservation Building Code (ECBC)** is applicable to both commercial and residential buildings. The minimum equipment efficiency values are prescribed with reference to local conditions, available systems and future prescriptions on minimum performance levels

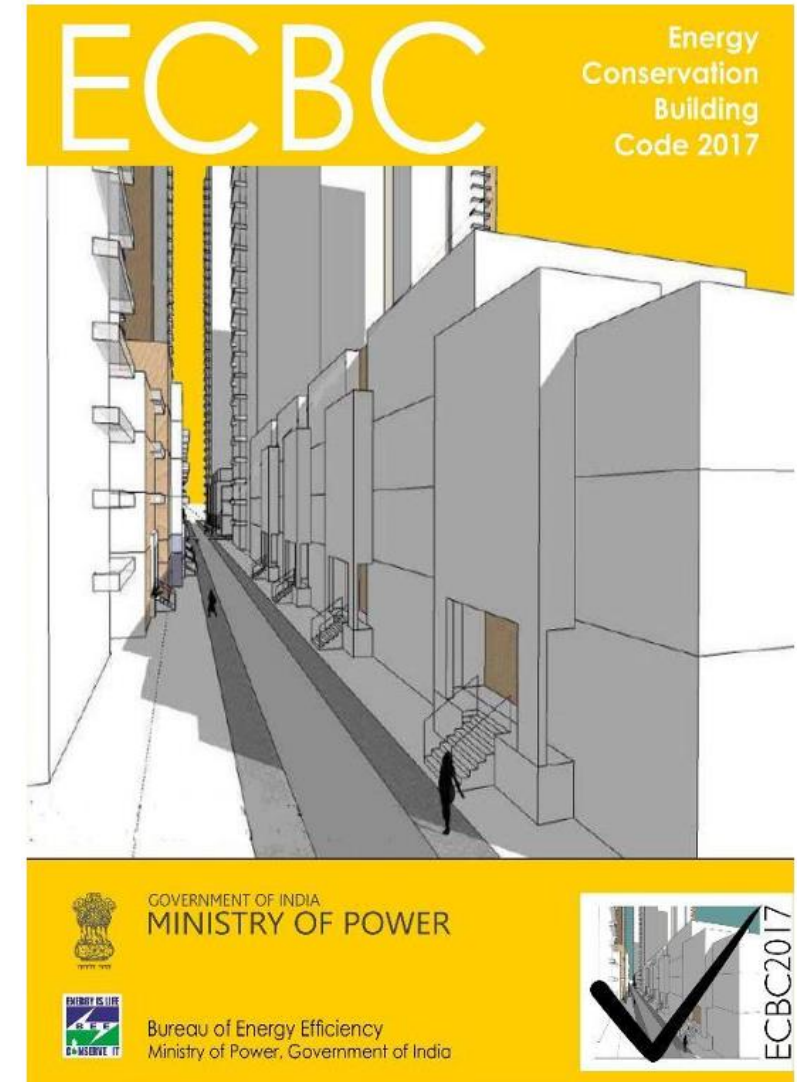

Image source: Bureau of Energy Efficiency, Government of India, 2017

# UNITARY AIR CONDITIONERS

ECBC 2017 (India) prescriptions for COP of unitary air conditioners

Requirements for unitary, split, packaged air conditioners

Cooling Capacity		ECBC Buildings		ECBC+ Buildings		Super ECBC Buildings	
kW <sub>r</sub>	TR	Water-cooled	Air-cooled	Water-cooled	Air-cooled	Water-cooled	Air-cooled
≤ 10.5	≤ 3	NA	BEE 3 Star	NA	BEE 4 Star	NA	BEE 4 Star
> 10.5	> 3	3.3 EER	2.8 EER	3.9 EER	3.4 EER	3.9 EER	3.4 EER

- The criteria given under ‘ECBC Buildings’ are mandatory in India as per ECBC 2017
- The criteria for ‘ECBC+ Buildings’ and ‘Super ECBC Buildings’ are optional; however, they give specifications for more efficient systems

Source: Bureau of Energy Efficiency, Government of India, 2017

# AIR COOLED VRF AIR CONDITIONERS

ECBC 2017 (India) prescriptions for COP of VRF air conditioners

Mandatory requirements for air-cooled variable refrigerant flow (VRF) air conditioners under ECBC Buildings

Type	Size category (kW <sub>r</sub> )	For Heating or cooling or both	
		EER (W/W)	IEER (W/W)
VRF Air	< 40	3.28	4.36
Conditioners, Air cooled	>= 40 and < 70	3.26	4.34
	>= 70	3.02	4.07

Source: Bureau of Energy Efficiency, Government of India, 2017

# CHILLER EFFICIENCIES

## ECBC 2017 (India) prescriptions for COP of chillers

### Mandatory requirements for chillers

Chiller	ECBC Buildings	ECBC+ Buildings	Super ECBC Buildings
All	BEE 1 star	BEE 3 star	BEE 5 star

### Star rating levels for water-cooled chillers

(valid from January 1, 2024 to December 31, 2025)

kW of Cooling	ISEER				
	1 Star	2 Star	3 Star	4 Star	5 Star
<260	4.80	5.20	5.60	6.10	6.60
>=260 and <530	5.00	5.60	6.20	6.80	7.40
>=530 and <1,050	5.50	6.10	6.70	7.40	8.20
>=1,050 and <1,580	5.80	6.50	7.20	7.90	8.70
>=1,580	6.00	6.70	7.40	8.20	9.00

### Star rating levels for air-cooled chillers

(valid from January 1, 2024 to December 31, 2025)

kW of Cooling	ISEER				
	1 Star	2 Star	3 Star	4 Star	5 Star
<260	3.00	3.30	3.60	4.00	4.40
>=260	3.10	3.50	3.90	4.30	4.70

Source: Bureau of Energy Efficiency, Government of India, 2017

# COOLING TOWER

## ECBC 2017 (India) prescriptions for cooling towers

### Prescribed cooling tower pumping power for ECBC, ECBC+ and Super ECBC Buildings

<i>Equipment type</i>	<i>Rating Condition</i>	<i>Efficiency</i>
Open circuit cooling tower Fans	35°C entering water	0.017 kW/kW <sub>r</sub>
	29°C leaving water	
	24°C WB outdoor air	
		0.31 kW/L/s

ECBC+ and Super ECBC Buildings have additional requirements for VFD installed in cooling tower fans

# PUMPS IN HVAC SYSTEMS

ECBC 2017 (India) prescriptions for power of pumps

Prescribed installed pumping power

Equipment	ECBC Buildings	ECBC+ Buildings	Super ECBC Buildings
Chilled Water Pumps (Primary and Secondary)	18.2 W/kW <sub>r</sub> with VFD on secondary pump	16.9 W/kW <sub>r</sub> with VFD on secondary pump	14.9 W/kW <sub>r</sub> with VFD on secondary pump
Condenser Water Pumps	17.7 W/kW <sub>r</sub>	16.5 W/kW <sub>r</sub>	14.6 W/kW <sub>r</sub>
Pump Efficiency	Min. 70%	Min. 75%	Min. 85%

Source: Bureau of Energy Efficiency, Government of India, 2017

# UTILITY PLANT ROOM

## ECBC 2017 (India) prescriptions for central chilled water plant

In ECBC 2017, the efficiency of the entire plant room has been specified for all categories of the buildings

System Type	Peak Building Cooling Load (kW)	
	< 3,516 kW	≥ 3,516 kW
Central Chilled Water Plant (Water Cooled)	0.21 (kW/kW <sub>r</sub> ) 0.74 (kW/TR)	0.20 (kW/kW <sub>r</sub> ) 0.70 (kW/TR)
Minimum system efficiency based on total installed equipment power per unit cooling capacity		

Reference System Efficiency	ECBC	ECBC+	Super ECBC
HVAC Plant Room, kW/kW <sub>r</sub>	0.26	0.23	0.20

Source: Bureau of Energy Efficiency, Government of India, 2017

# AHU FAN EFFICIENCIES

## ECBC 2017 (India) prescriptions on minimum AHU fan efficiencies

### Prescribed minimum mechanical efficiency and motor efficiency for fans in ECBC Buildings

<i>System type</i>	<i>Fan Type</i>	<i>Mechanical Efficiency</i>	<i>Motor Efficiency (As per IS 12615)</i>
Air-handling unit	Supply, return and exhaust	60%	IE 2

### Prescribed minimum mechanical efficiency and motor efficiency for fans in ECBC+ Buildings

<i>System type</i>	<i>Fan Type</i>	<i>Mechanical Efficiency</i>	<i>Motor Efficiency (As per IS 12615)</i>
Air-handling unit	Supply, return and exhaust	65%	IE 3

### Prescribed minimum mechanical efficiency and motor efficiency for fans in Super ECBC (ECBC+) Buildings

<i>System Type</i>	<i>Fan Type</i>	<i>Mechanical Efficiency</i>	<i>Motor Efficiency (As per IS 12615)</i>
Air-handling unit	Supply, return and exhaust	70%	IE 4

Source: Bureau of Energy Efficiency, Government of India, 2017

# TYPICAL COOLING SYSTEM (CENTRALIZED)

Two key segments

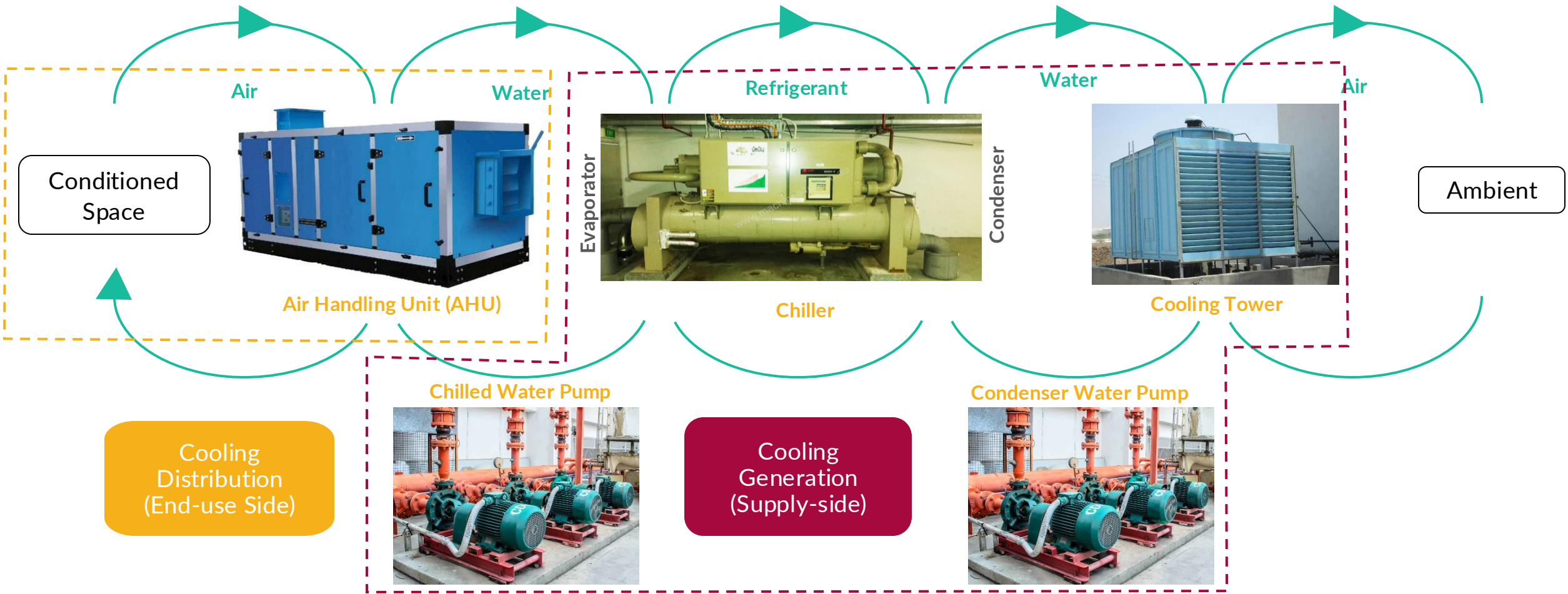

# OPTIMIZING CENTRALIZED SYSTEM

## Key strategies

### Cooling Generation

- Increase the chilled water generation temperature
- Decrease the condenser water temperature
- Use VFD for chillers
- Pump selection

### Cooling Distribution

- Minimize the air distribution path
- Enthalpy recovery
- Free cooling
- Use VFDs

Use building management systems (BMS) and building automation systems (BAS) to optimize operations

# CHILLED WATER TEMPERATURE

Design option for operation at higher chilled water temperature

Design for higher chilled water temperature:  
Radiant cooling system

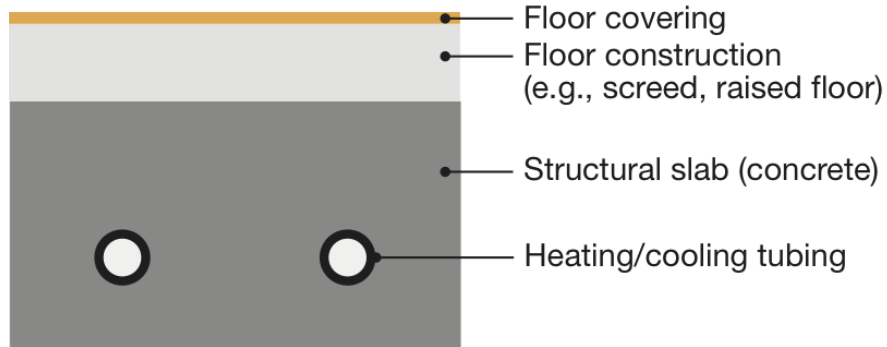
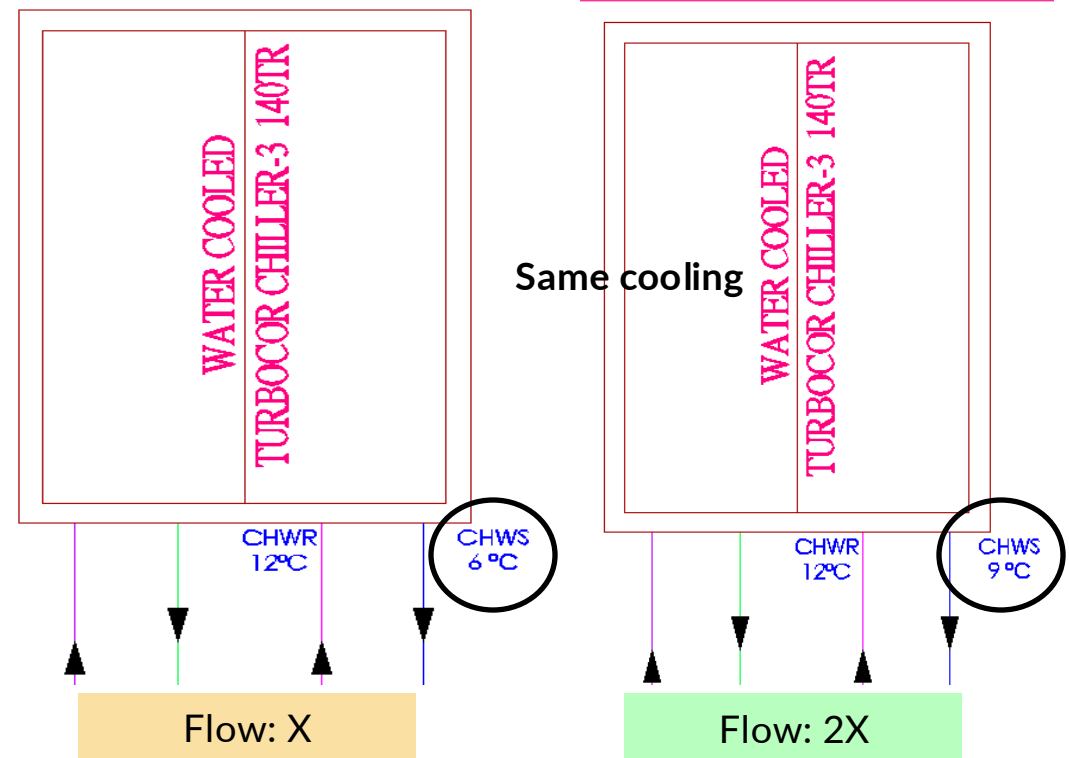

Image source: Infosys. India

Operate at higher chilled water temperature



Limiting factor: Temperature required for dehumidification

# CHILLED WATER TEMPERATURE

Impact of operation at higher chilled water temperature

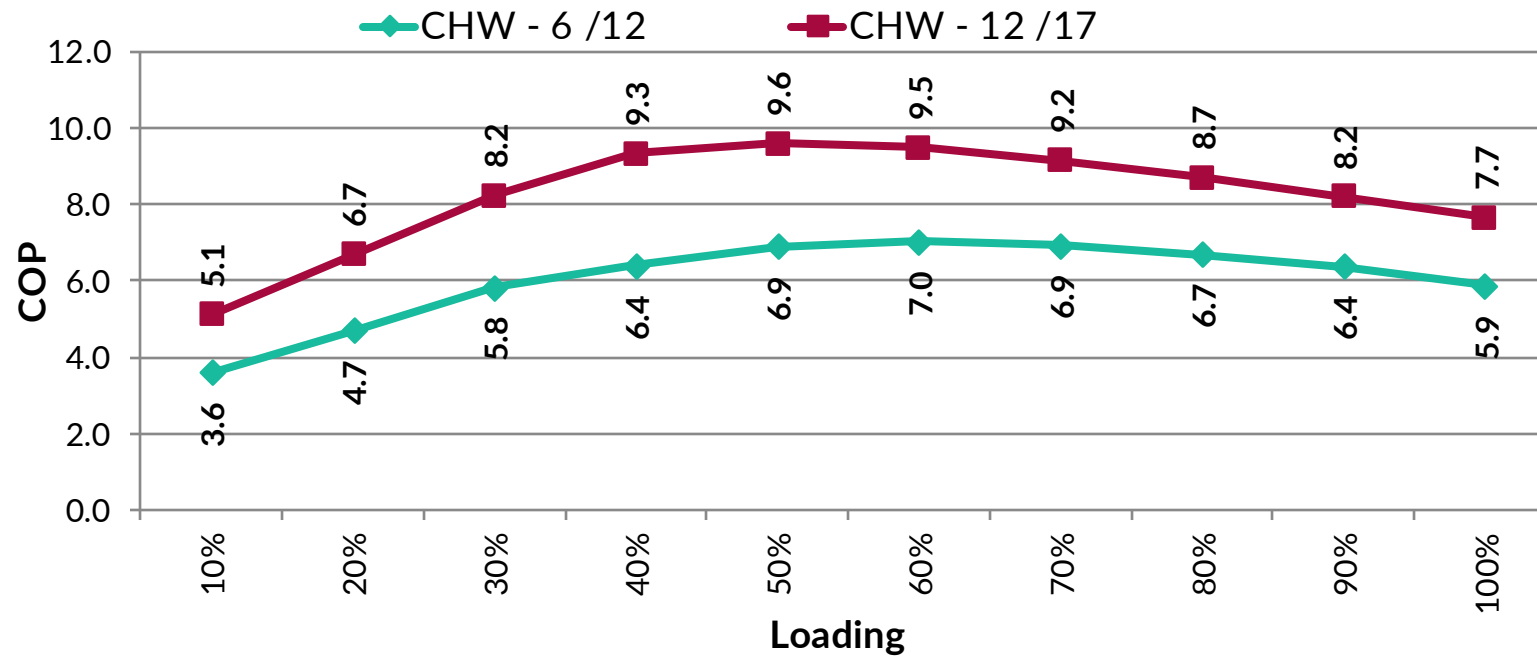

**Note:** At constant condenser cooling water inlet / outlet temperatures of 28°C / 34°C

Less power input for compressor; leading to increase in COP

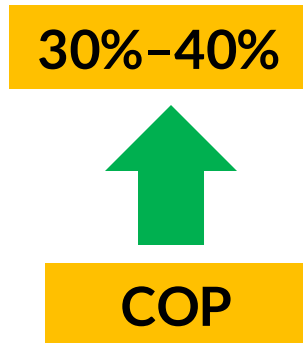

# COOLING WATER TEMPERATURE

## Options for lower condensing temperature

- Use water cooling or evaporative cooling of condensers instead of air-cooled condensers. This is desirable for reducing chiller power consumption
- Use cooling tower with low approach temperature (1°C–2°C) to improve heat transfer effectiveness in the condenser. This lowers the condensing temperature, thus, reduces the power input for the compressor and increases COP
- The limiting factor is water availability. Due to water scarcity, many urban local bodies in India do not permit the use of freshwater for HVAC cooling applications

Parameters	Unit	Water-cooled Chiller	Air-cooled Chiller	Evaporative Chiller
Refrigerant		R-134 a	R-134 a	R-134 a
Capacity	TR	100	100	100
Water Flow across Condenser	m <sup>3</sup> /hr	60.5	NA	30.3
Condenser Pump Power	kW	5.51	NA	1.52
Condenser / CT Fan Power	kW	NA	15.12	NA
Compressor Power Consumption	kW	77.56	110.22	66.44
<b>Specific Power Consumption</b>	<b>kW/TR</b>	<b>0.78</b>	<b>1.10</b>	<b>0.66</b>
Evaporator Refrigerant Temp.	°C	2.0	2.0	2.0
Evaporator Refrigerant Pressure	bar	3.1	3.1	3.1
Condenser Refrigerant Pressure	bar	8.5	11.3	7.6
Condenser Refrigerant Temp.	°C	33.5	44.0	29.5
Make Up Water Requirement	m <sup>3</sup> /hr	0.58	NA	0.52

# DECREASING CONDENSER WATER TEMPERATURE

What's the impact?

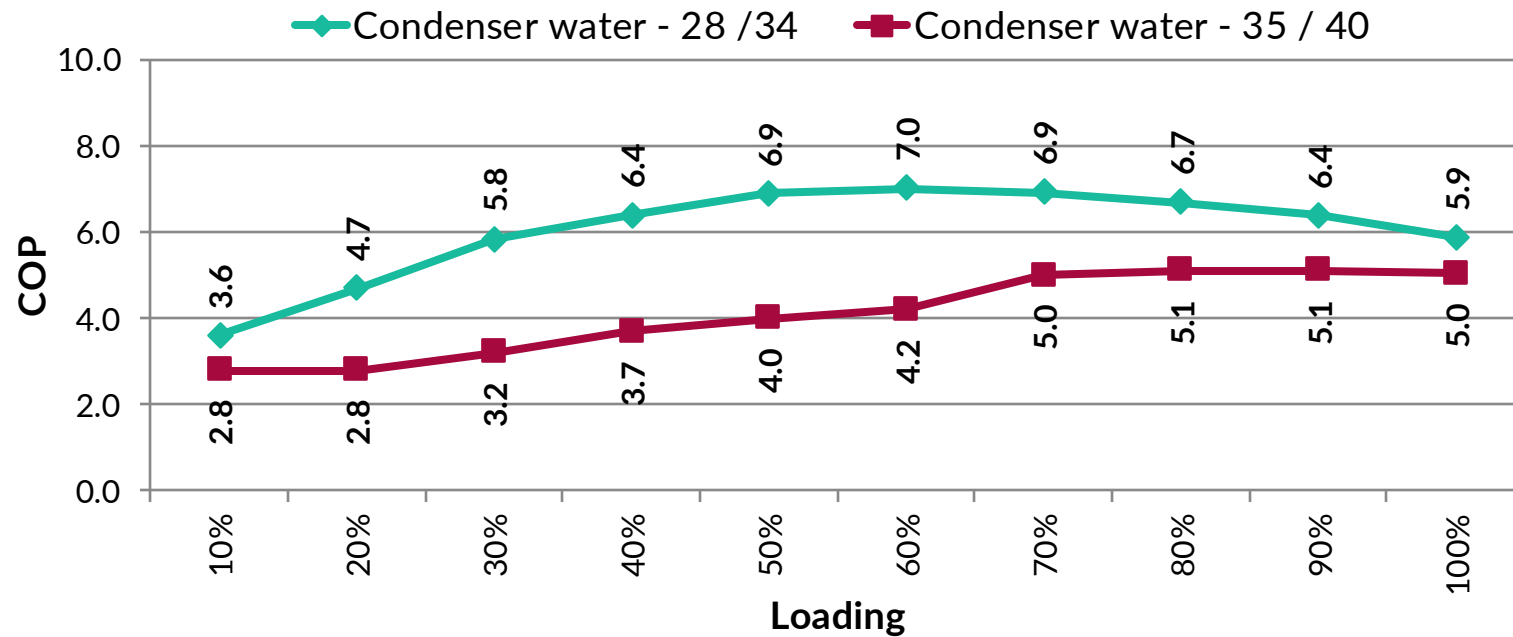

Less power input for compressor;  
leading to increase in COP

20%-50%



COP

**Note:** At constant chilled water inlet / outlet temperatures of 12°C / 6°C

# VFD FOR CHILLERS

## Energy efficient capacity control at partial loads

- Variable frequency drive (VFD) varies the electrical frequency to electric motor speed, eliminating the need for relatively inefficient methods of capacity control like cylinder unloading for reciprocating compressors, sliding valve control for screw compressors and inlet guide vane control for centrifugal compressors
- Elimination of energy losses from these inefficient capacity control devices, coupled with significant improvements in heat transfer effectiveness in evaporator and condenser, the chiller COP increases dramatically
- As the chillers operate on part-load most of the time, the energy consumption reduces significantly

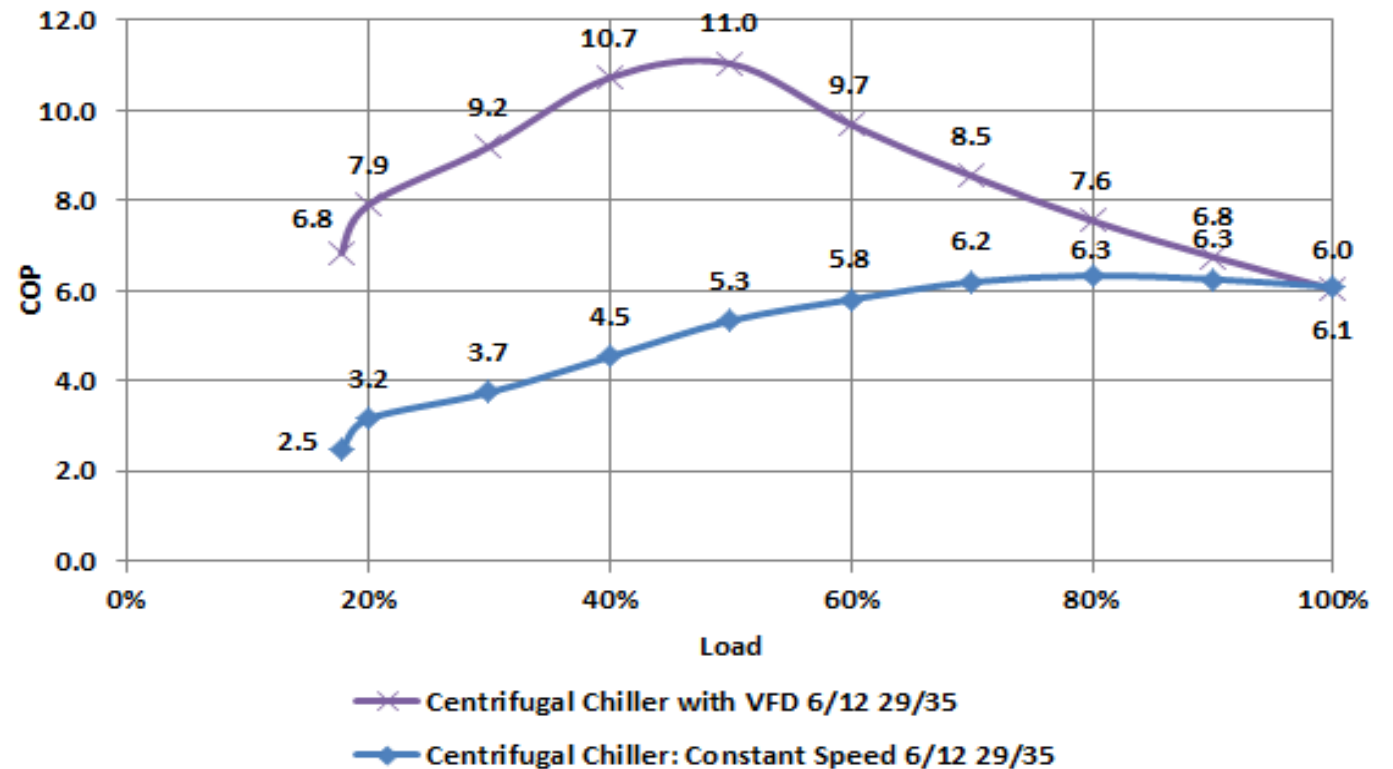

Source: Ministry of Power, Government of India, 2022a

# PUMPS SELECTION

Selection of appropriately sized, efficient pumps

- In the HVAC system, flow through condenser and evaporator is important, and minimum flow must be maintained for smooth functioning of chillers
- The pressure drop across condenser and evaporator, associated friction drop on piping, and static lift determine the operating energy consumed by the pumps. These parameters should be calculated accurately before selection of pumps
- The head and flow for the pumps must be selected with minimum margins and maximum available pump efficiency to ensure efficient operation
- In case the selected head is more than the operating head, then the pump would tend to deliver more flow than the design value and would consume more power and operate at lower efficiency

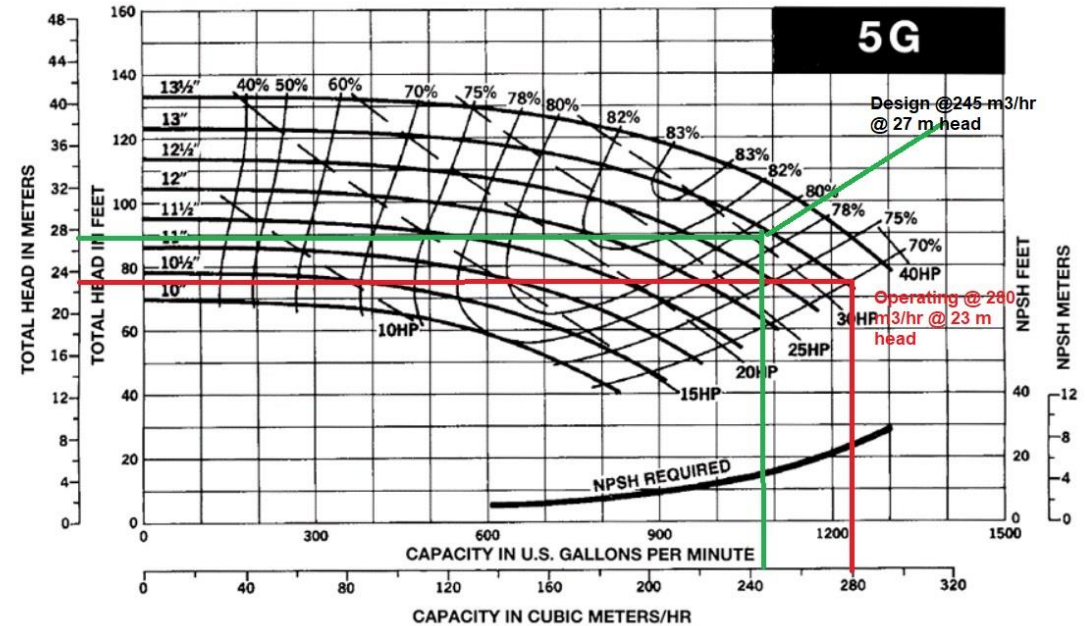

# RADIANT COOLING

Leveraging the heat carrying capacity of water

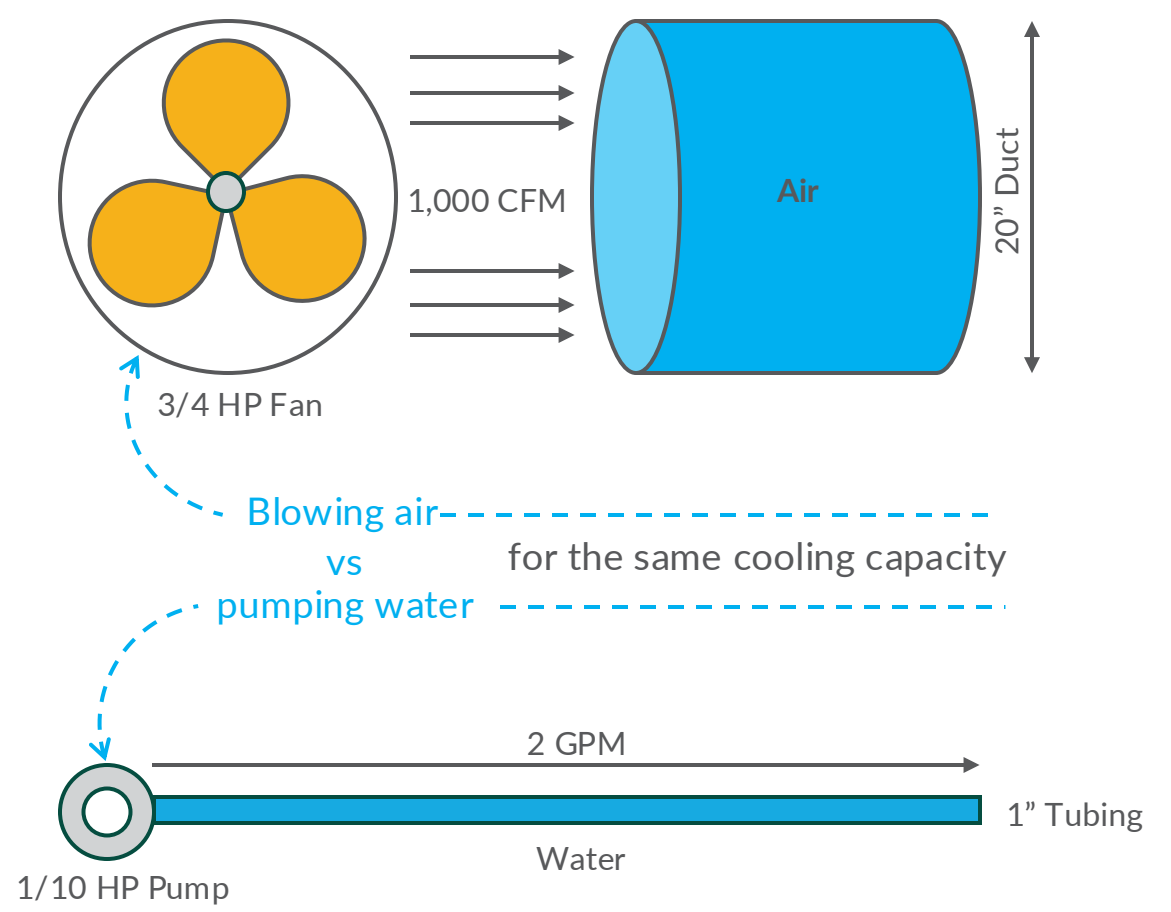
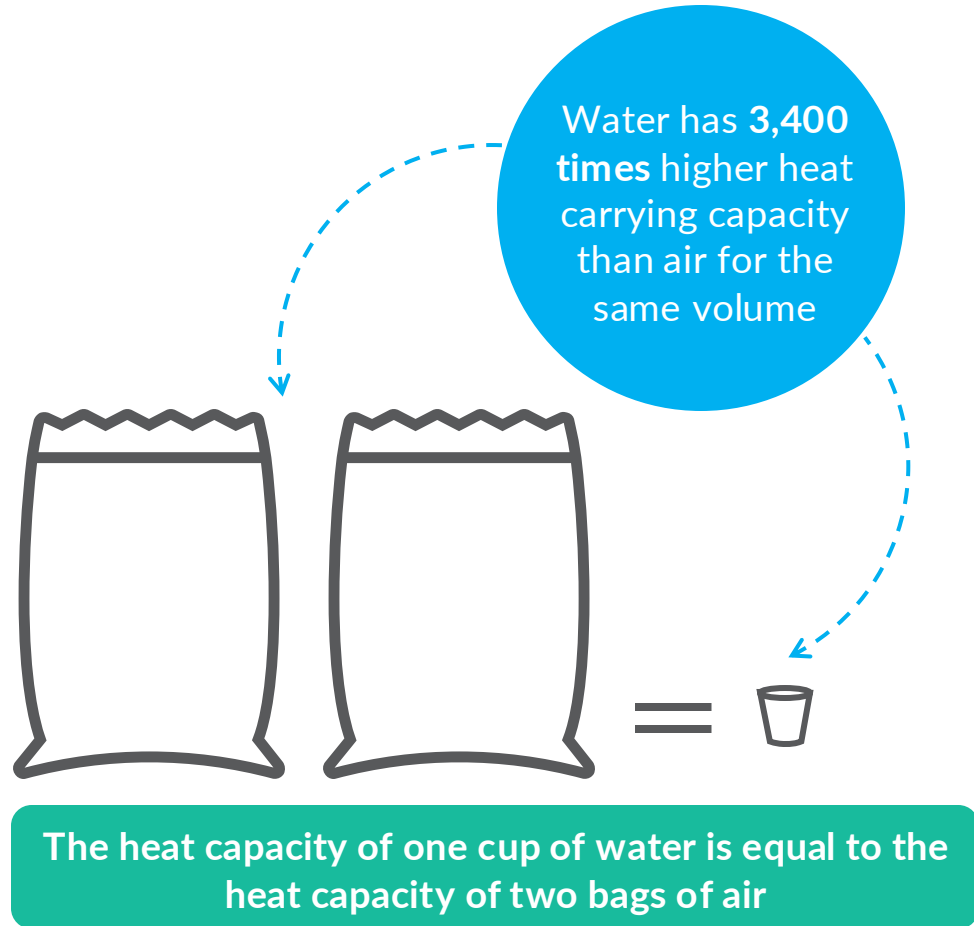

# MINIMIZE COOL AIR DUCTING

Chilled water is comparatively a better heat transfer medium than air

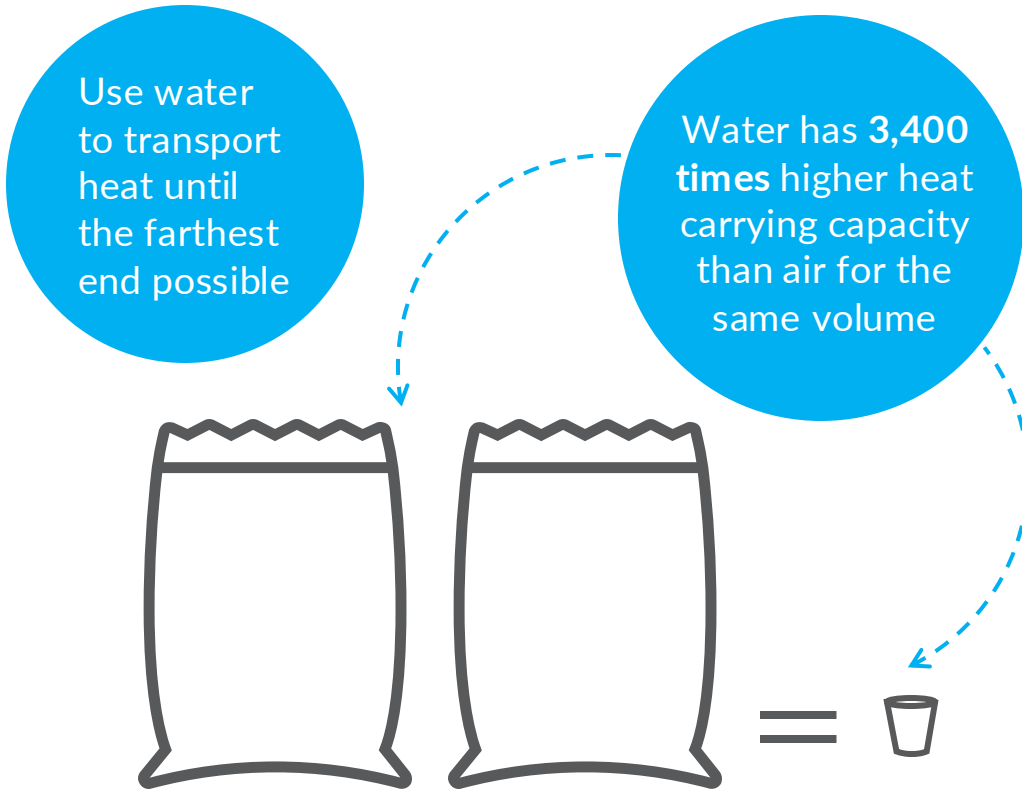

The heat capacity of one cup of water is equal to the heat capacity of two bags of air

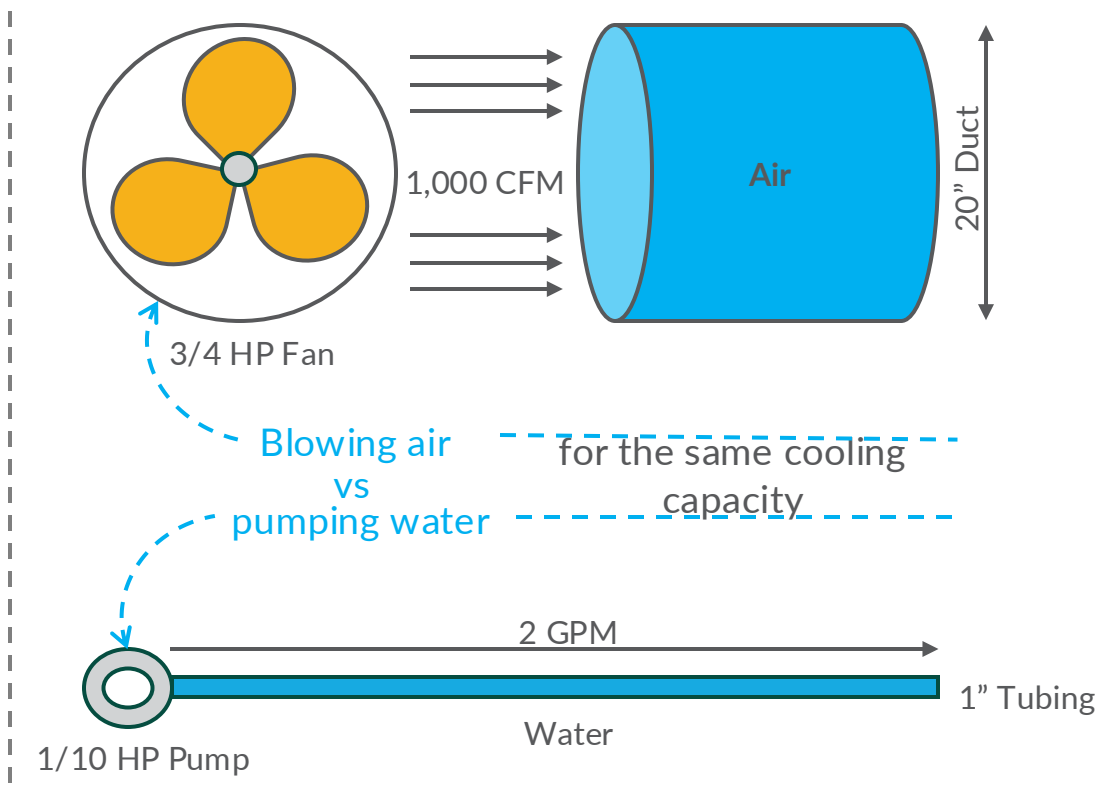

Pumping energy is 7.5 times lower

# USE ENTHALPY RECOVERY AT AHU

Cooling generated must be recovered to reduce losses

Enthalpy recovery wheel (ERW) recovers both sensible and latent heat



Typical AHU



Enthalpy Recovery Wheel

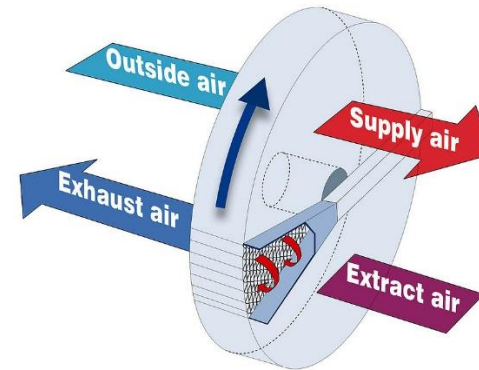

43°C DB

38°C DB

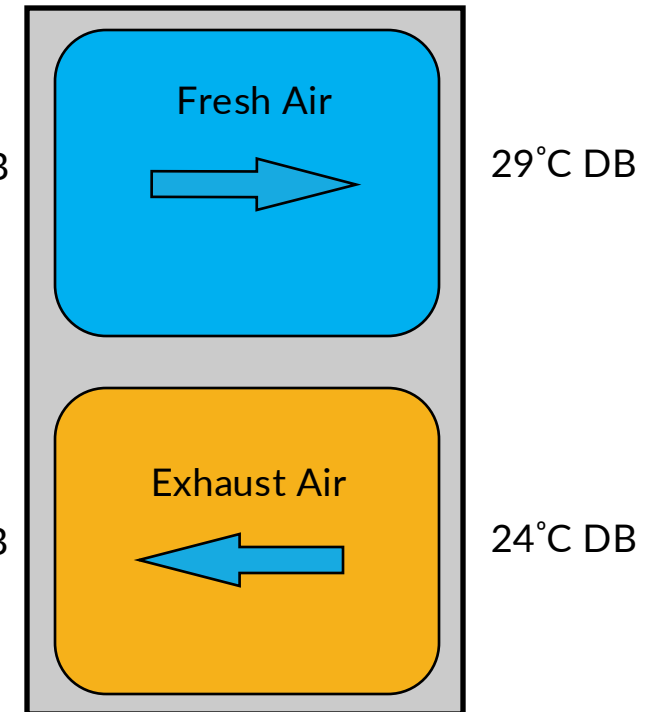

Example of heat recovery wheel: Effectiveness (74%)

The operational energy required for cooling / dehumidifying the fresh air is reduced by using ERW, which is indicated by its effectiveness

# FREE COOLING

## Provision in air handling unit (AHU)

- Free cooling uses ambient air whenever the temperature and humidity is suitable to cool the building
- Two separate openings are needed in the AHU: one for minimum fresh air and a larger opening for 100% fresh air (free cooling). There should be provision in the AHU to bypass the cooling coil when free cooling is availed
- For optimal utilization, the AHU switching between chiller-based cooling and free cooling should be automated with the use of enthalpy sensors

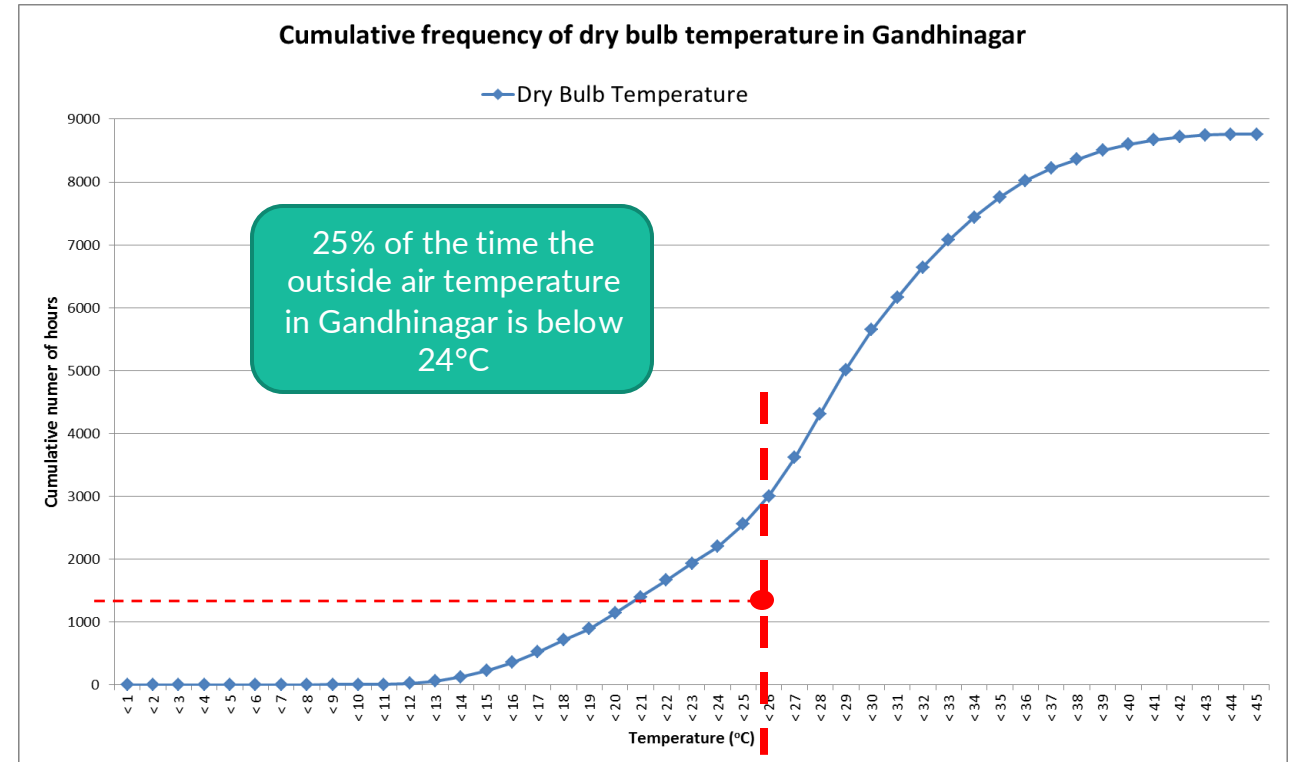

Example: Free cooling potential for Gandhinagar, India

# VFD FOR FANS AND PUMPS

## Optimize part-load operations

- As the cooling load varies, the water and air flow requirements also vary
- Conventional methods like damper throttling and inlet guide vanes are not efficient methods due to significant throttling losses
- Using VFDs for fans and pumps to meet the varying flow requirement at part loads, can save 50%–60% of energy

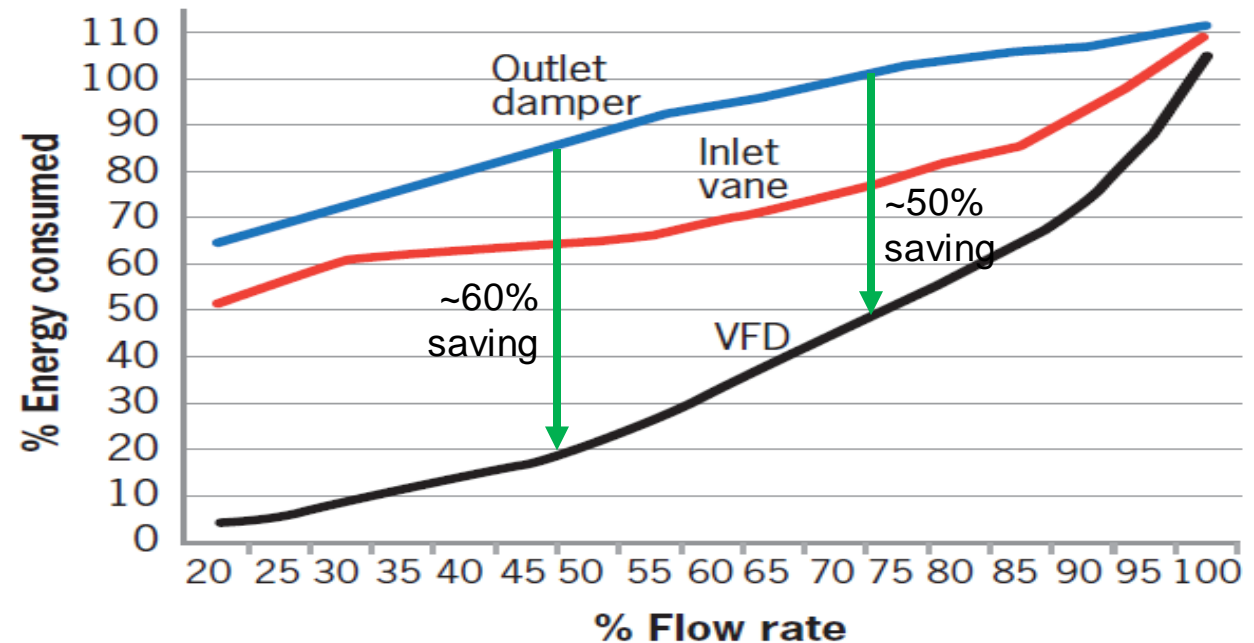

Energy savings with VFDs at lower flows in comparison to damper and IGV controls

Source: Ministry of Power, Government of India, 2022a

# BMS CONTROL

For optimizing operational energy

- A building management system (BMS) is a useful tool for optimizing operational energy
- BMS algorithms can simultaneously consider the external factors (climate), and internal factors (operations, occupancy, micro-climate, indoor air quality, thermal and visual comfort), and optimize energy and water consumption
- Now, with artificial intelligence (AI) and machine learning (ML) algorithms, the BMS can automatically reset itself to the best combination
- BMS is useful as historical data and trends can easily be accessed for troubleshooting

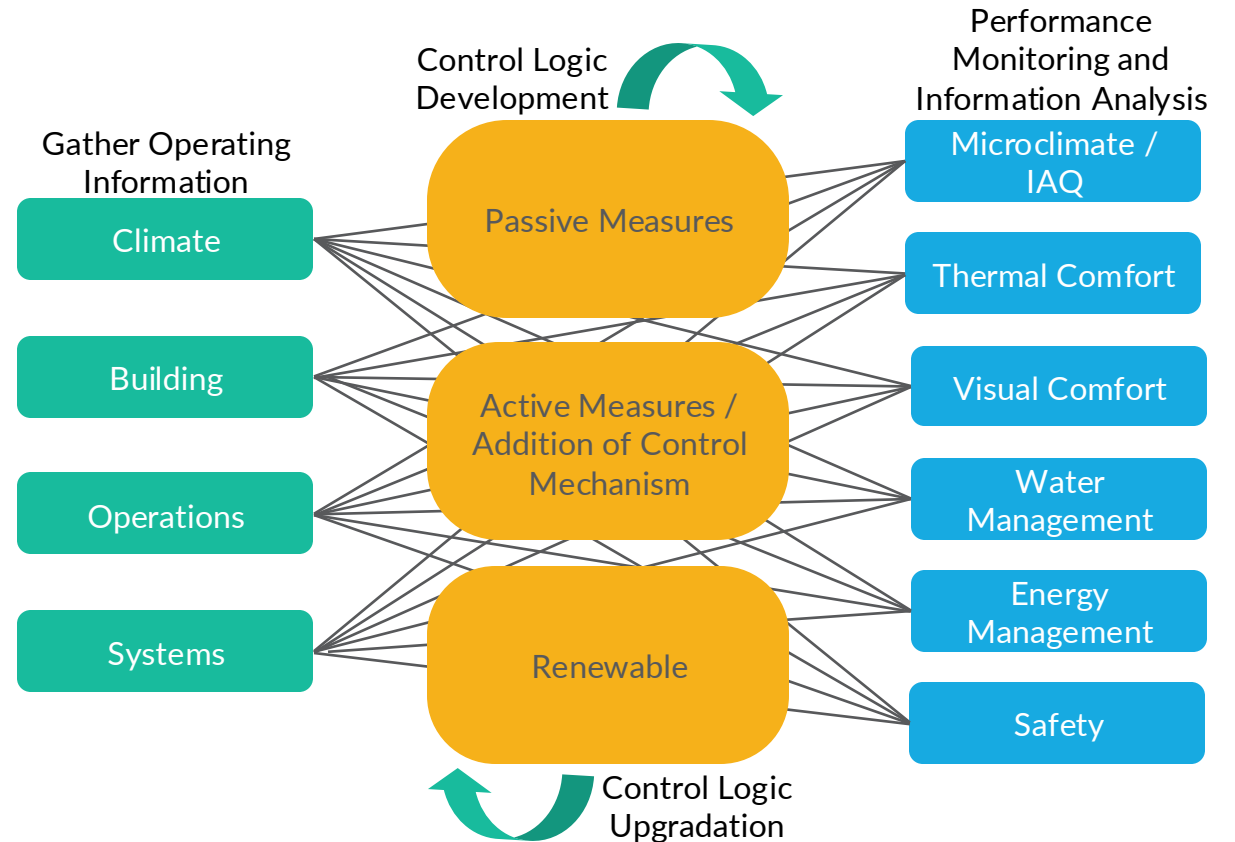

# Optimizing Other Services

Use of Star-rated Equipment and Appliances

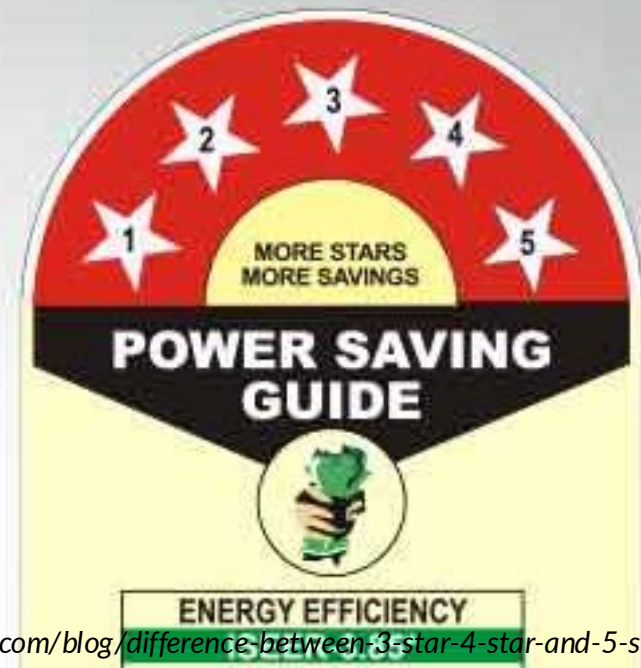
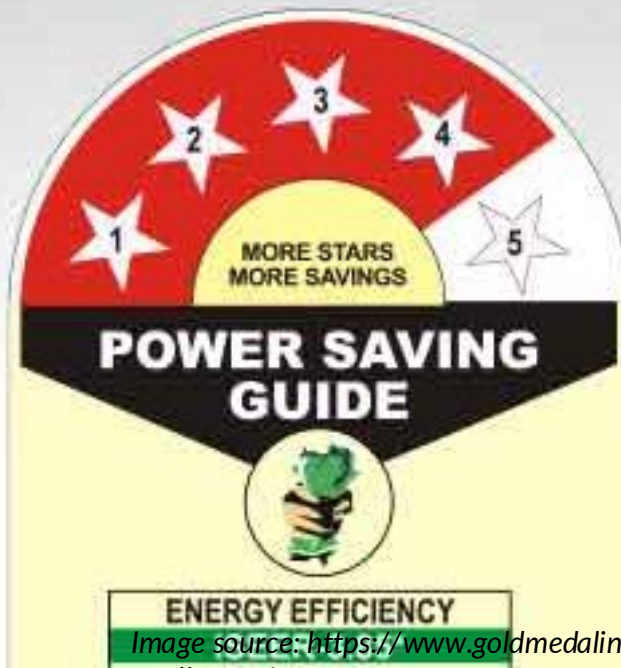
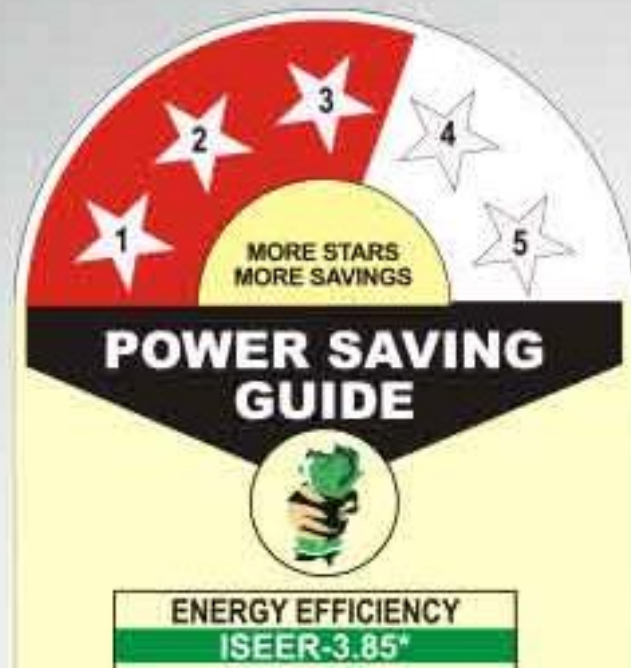

# STAR-RATED APPLIANCES

Residential apartment: Savings with energy efficient BLDC ceiling fans

Room Specifications	35W BLDC Fan		70W Capacitor Start Fan	
	Quantity	Operating Hours	Quantity	Operating Hours
Hall	1	12	1	12
BD 01	1	8	1	8
BD 02	1	8	1	8
Kitchen	0	0	0	0
Toilet 01	0	0	0	0
Toilet 02	0	0	0	0
Corridor	0	0	0	0
<b>Installed Power</b>	<b>105W</b>		<b>210W</b>	
<b>Energy Consumed</b>	<b>980Wh</b>		<b>1960Wh</b>	



Source: Bureau of Energy Efficiency, Government of India

# STAR-RATED APPLIANCES

Water pumps and heaters: Energy saving potential

Head (m)	Discharge (liters per second)	Rating (kW)	Power Consumption of Unrated Pump Motor (kW)	Power Consumption of 5-star Pump Motor (kW)	Annual Energy Savings (kWh/year)
73	6.67	7.5	11	9	1,600
122	6.6	13	17.5	14.5	2,400



Capacity of Water Heater (liter)	Standing Losses in Unrated Conventional Water Heater (kW)	Standing Losses in 5-star Rated Water Heater (kW)	Energy Savings (kWh/year)
25	0.823	0.562	65
35	0.940	0.642	75



Source: Bureau of Energy Efficiency, Government of India

# STAR-RATED APPLIANCES

## Refrigerators

Type	Storage Volume (liter)	Annual Energy Consumption of an Unrated Refrigerator (kWh/year)	Annual Energy Consumption of a 5-star Rated Refrigerator (kWh/year)	Annual Energy Savings (kWh/year)
Frost Free	190	379	155	224
	250	400	164	236
	300	418	171	247
Direct Cool	190	339	138	201
	260	346	148	198
	310	379	154	225



Source: Bureau of Energy Efficiency, Government of India

# OTHER SERVICES AND SYSTEMS

## Elevators

- **Compliance:** Guideline VDI 4707: Class 1–5 for energy efficiency of lifts
- **Type of motor:** Use of IE3 motor and above
- Use of variable voltage variable frequency drives and regenerative drives
- **Lumen efficacy of lamps used in elevators:** Over 95 lumen/W



Source: Bureau of Energy Efficiency, Government of India, 2024

# Integration of Renewable Energy



Image source: <https://earth.org/the-present-and-future-of-renewable-energy-a-2023->

# RENEWABLE ENERGY INTEGRATION

Renewable energy sources

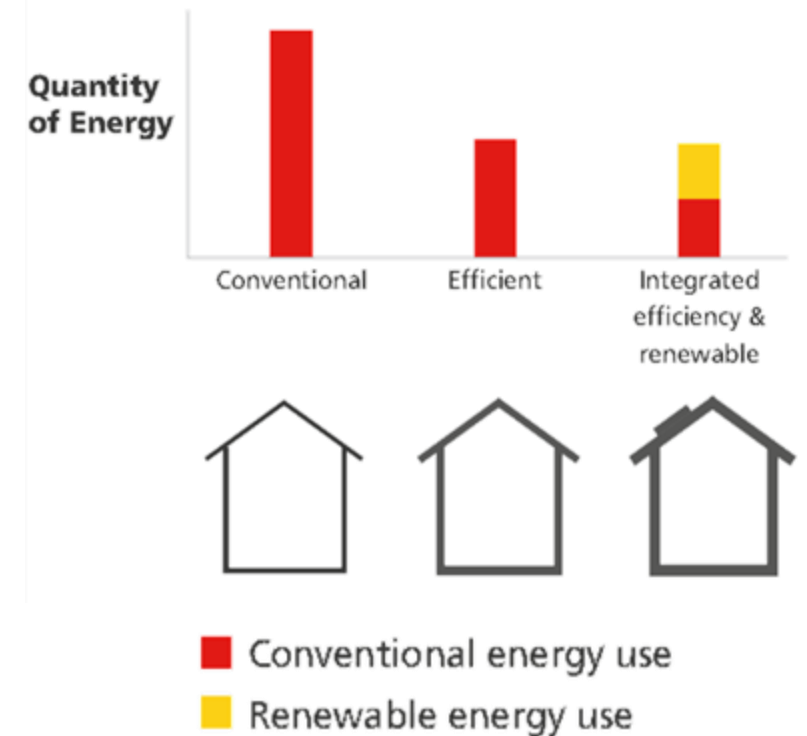
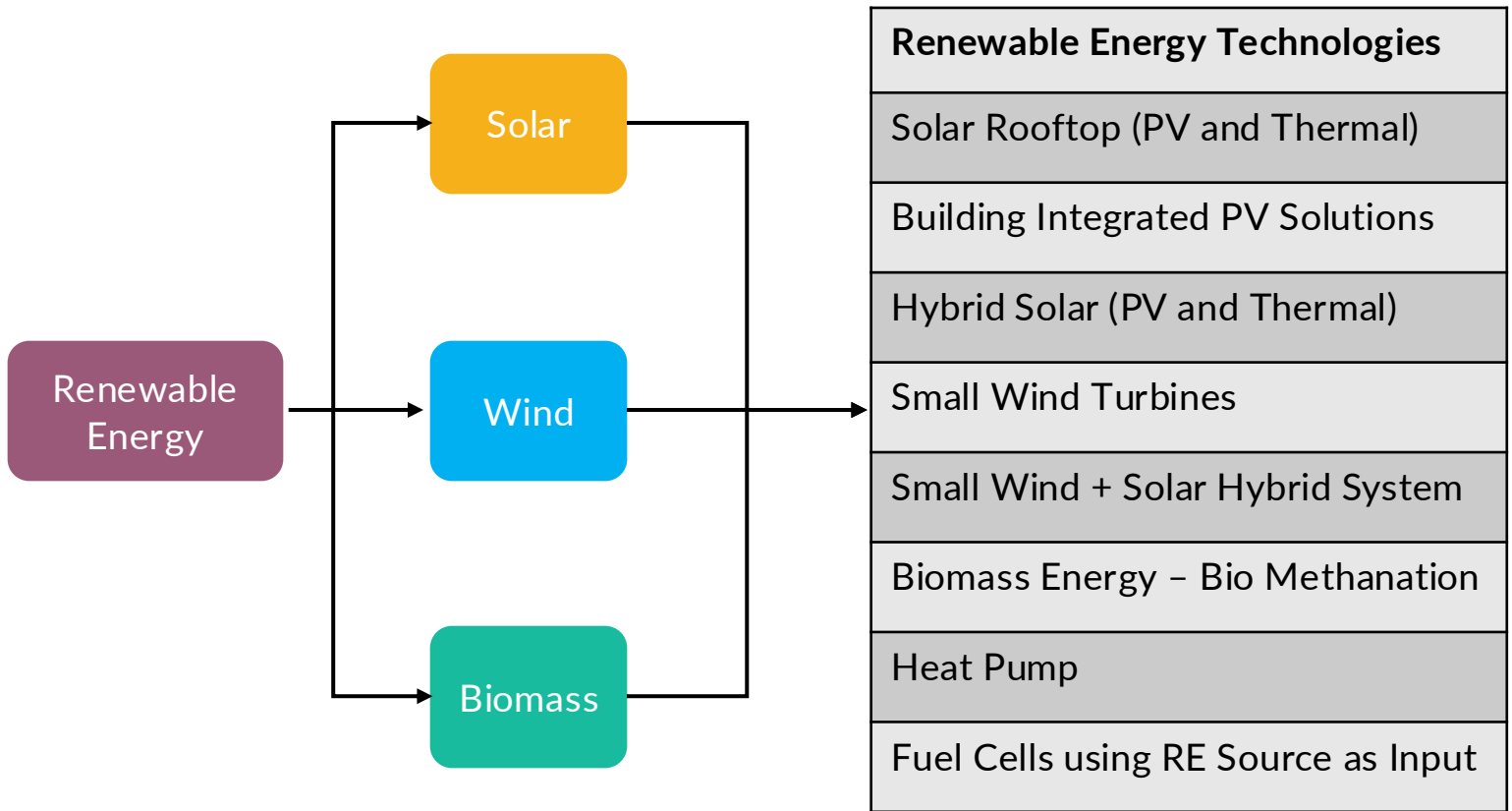

Source: Swiss Agency for Development and Cooperation and International Institute for Energy Conservation, 2022

# RENEWABLE ENERGY INTEGRATION

## Photovoltaic (PV) system: Solar electrical power

PV systems fall into two main categories: Grid-connected and off-grid

### Grid-tied systems:

- The system is connected to the local electricity distribution grid; energy generated is sent to the utility grid
- A credit for the energy generated is provided
- Grid acts as an energy storage unit

### Off-grid systems:

- The system is independent of the local electricity distribution grid
- Energy generated is either consumed in real-time or stored in batteries

Grid-tied System

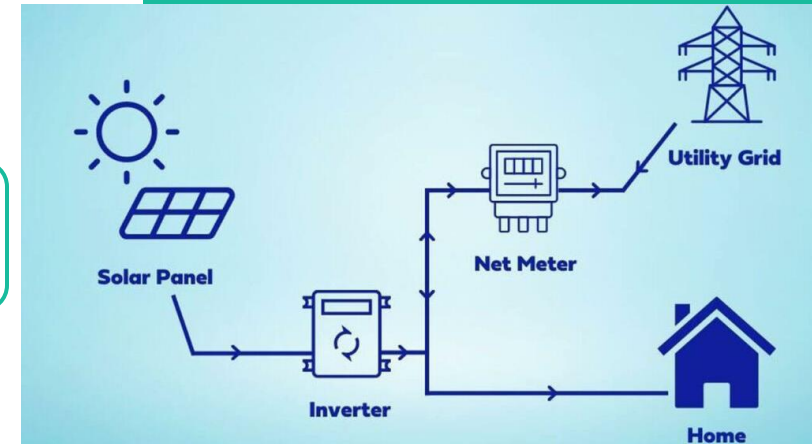

Off-grid System

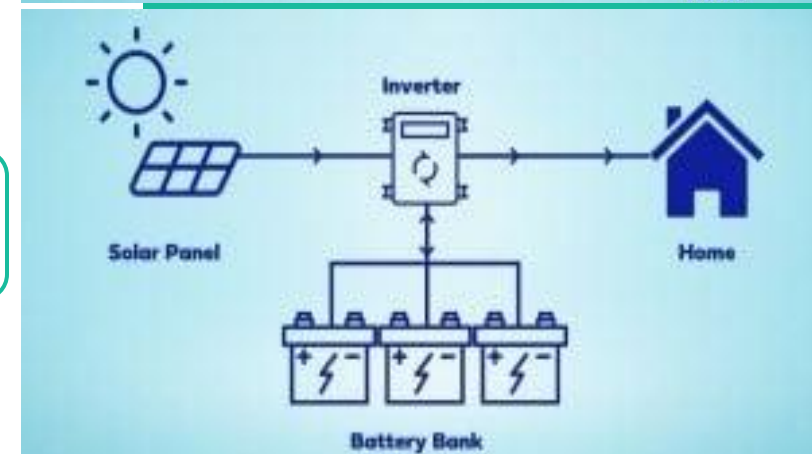

Source: Swiss Agency for Development and Cooperation and International Institute for Energy Conservation, 2022

# RENEWABLE ENERGY INTEGRATION

## Photovoltaic (PV) system: Solar electrical power

- The rating of the solar panels is given in **kilowatts peak (kWp)**
- **Standard test conditions (STC):**
  - Irradiance of  $1,000 \text{ W/m}^2$
  - Module temperature at  $25^\circ\text{C}$
  - Solar spectrum of AM 1.5
- As a rule of thumb, 1 kWp system in India generates around 4–5 kWh/day, and requires about  $10 \text{ m}^2$  shadow free roof area



Source: Swiss Agency for Development and Cooperation and International Institute for Energy Conservation

# RENEWABLE ENERGY INTEGRATION

## Solar thermal system

- A solar thermal system works by harnessing the sun's energy and converting it into heat that is transferred into a home or business heating system as hot water or space heating
- There are two types of solar water heater systems:
  - i. Flat Plate Collector
  - ii. Evacuated Plate Collector
- A 100-liter capacity solar water heater (SWH) can replace an electric water heater for residential use and save 1,500 units of electricity
- A SWH of 100-liter capacity can prevent the emissions of 1.5 tons of carbon dioxide per year
- The use of 1,000 SWHs of 100-liter capacity each can contribute to a peak load saving of 1 MW
- A 100 LPD solar collector usually has dimensions of 1m x 2m (requiring 3m<sup>2</sup> rooftop area per collector)

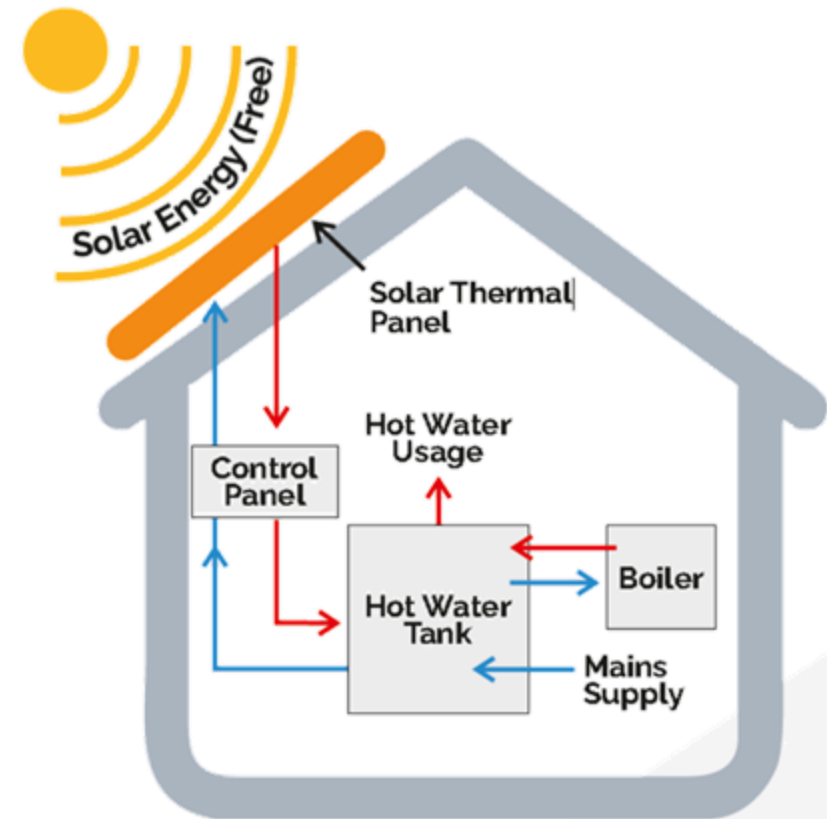

Source: Swiss Agency for Development and Cooperation and International Institute for Energy Conservation

# RENEWABLE ENERGY INTEGRATION

## Wind turbines

- Micro wind turbines, called 'building-integrated wind turbines' or 'vertical axis wind turbines' are suitable for building scale applications
- The main components of a wind turbine include blades, rotors, gearboxes and generators
- Vertical axis wind turbine generators (200W – 10kW) can be used as standalone systems or as grid-connected systems, and both can be paired with other energy conversion systems, such as photovoltaics
- Wind turbines can generate energy throughout the day and the system does not require frequent cleaning
- The low cut in speed turbines start generating power at 2.5m/s – 3m/s wind speed, without creating aerodynamic noise
- The wind turbine should be installed at the highest point of the site where no wind turbulence will be caused by any other building or site elements like trees

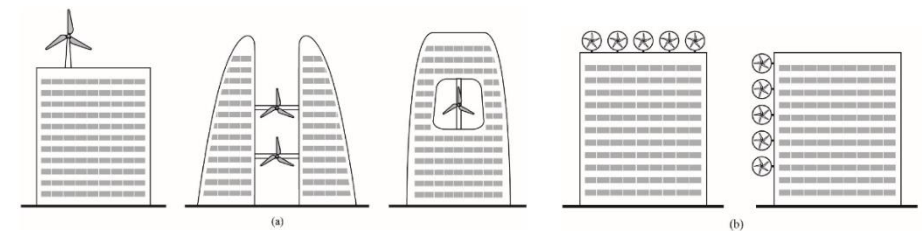

Source: Swiss Agency for Development and Cooperation and International Institute for Energy Conservation

# RENEWABLE ENERGY INTEGRATION

## Biomass energy

- Biomass is used for facility heating, electric power generation, and combined heat and power
- The term biomass encompasses a large variety of materials, including wood from various sources, agricultural residues, and animal and human waste
- Biomass can be converted into electric power through several methods:
  - Direct combustion of biomass material, such as agricultural waste or woody materials
  - Gasification of biomass produces a synthesis gas with usable energy content by heating the biomass with insufficient oxygen
  - Pyrolysis yields bio-oil by rapidly heating the biomass in the absence of oxygen
  - Anaerobic digestion produces a renewable natural gas when organic matter is decomposed by bacteria in the absence of oxygen

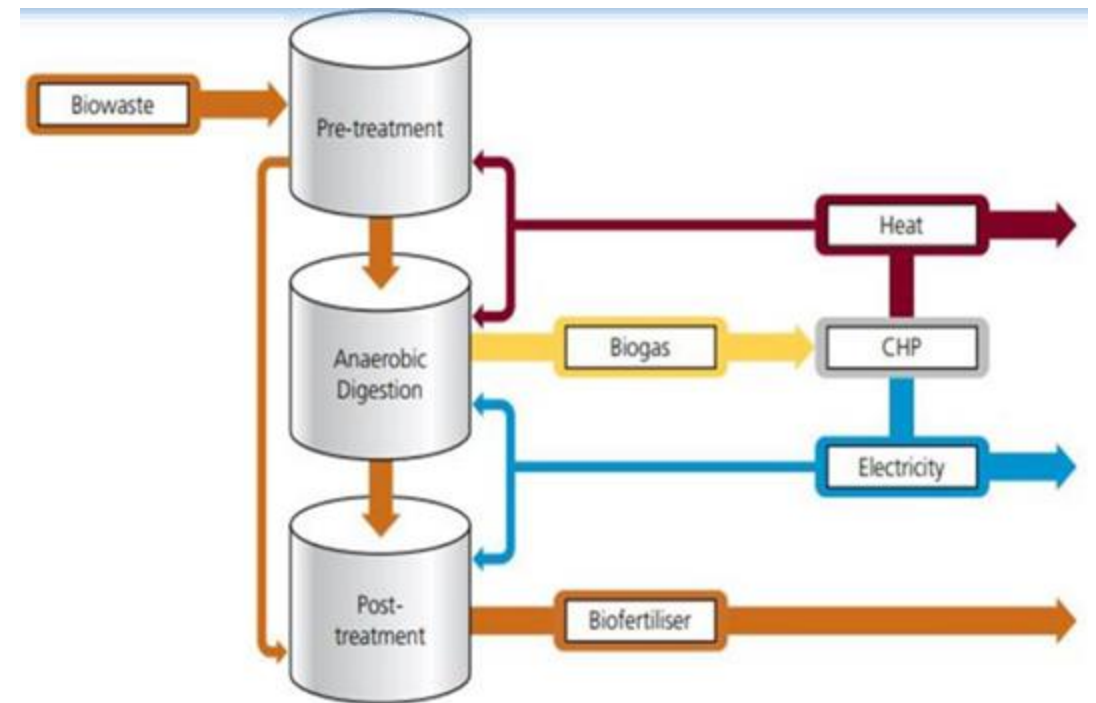

Source: Swiss Agency for Development and Cooperation and International Institute for Energy Conservation

# Thank you!

For more information, visit us at <https://ALCBT.GGGI.ORG>  
or scan the QR code below



## IKI Independent Complaint Mechanism

Any person who believes they may be harmed by an IKI project or who wish to report corruption or the misuse of funds, can lodge a complaint to the IKI Independent Complaint Mechanism at [IKI-complaints@z-u-g.org](mailto:IKI-complaints@z-u-g.org). The IKI complaint mechanism has a panel of independent experts who will investigate the complaint. In the course of the investigation, we will consult with the complainant so as to avoid unnecessary risks for the complainant. More information can be found at <https://www.international-climate-initiative.com/en/about-iki/values-responsibility/independent-complaint-mechanism/>.

 [www.gggi.org](http://www.gggi.org)

 [@gggi\\_hq](https://twitter.com/gggi_hq)

 [@GGGIHQ](https://www.instagram.com/gggi_hq)

 [@GGGIHQ](https://www.facebook.com/gggi_hq)

 [@gggi\\_hq](https://www.linkedin.com/company/gggi_hq)

 [@GGGIMedia](https://www.youtube.com/channel/UCGgI-Media)



Supported by:



on the basis of a decision  
by the German Bundestag

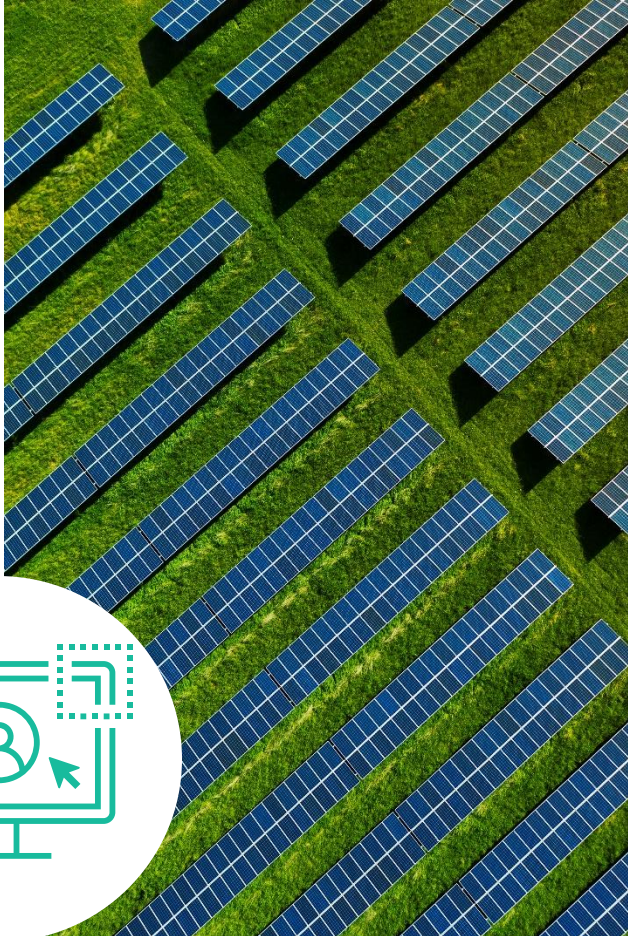

ASIA LOW CARBON  
BUILDINGS TRANSITION  
*Life Cycle Assessment for Transitioning  
to a Low-Carbon Economy* | PROJECT

## 2.6 Understanding the Basics of Energy Management

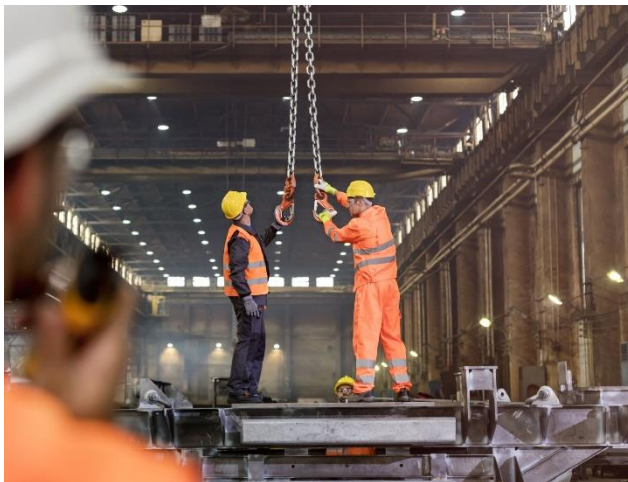
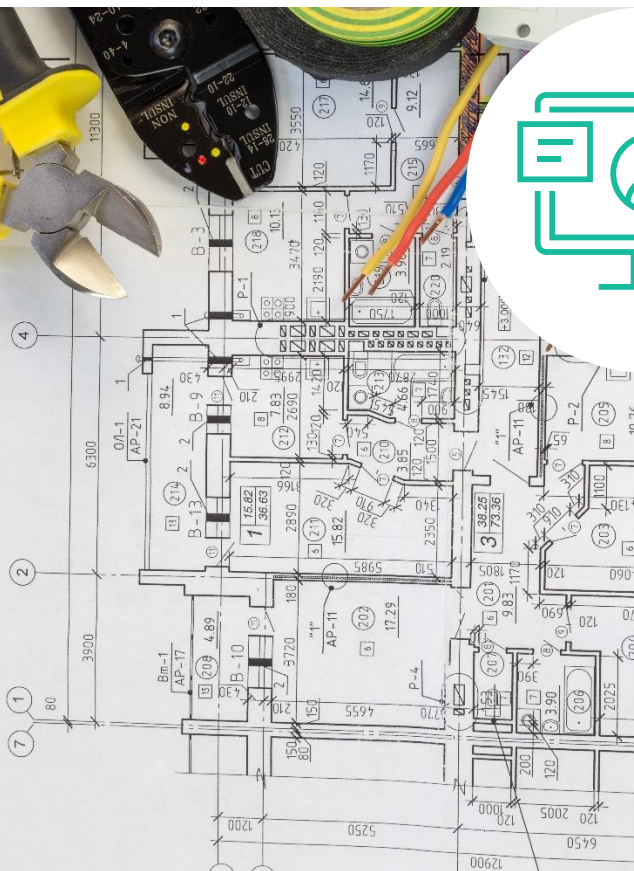

November 2024



HEAT

Supported by:



on the basis of a decision  
by the German Bundestag

# WHAT WILL YOU LEARN?

Classification of building types and energy use requirements

Energy benchmarks for different building types, including building star rating thresholds in India

Energy management approaches, systems and tools available for building facility managers

Building management and automation systems for energy optimization

Case examples

01

02

03

04

05



Image source: <https://damiaglobalservices.com/building-energy-management-system/>

# BUILDINGS

## Classification by type

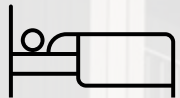

### Hospitality

- No Star
- Resorts
- Star Hotels



### Healthcare

- Hospitals
- Out-patient Care



### Assembly

- Theaters
- Transport Service Facilities
- Multiplexes



### Business

- Small Offices: <10,000 sqm
- Medium Offices: 10,000–30,000 sqm
- Large Offices: >30,000 sqm

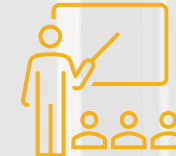

### Education

- Schools
- Colleges
- Universities
- Training Institutions



### Retail

- Shopping Malls
- Stand-alone Retails
- Open Gallery Malls
- Supermarkets

# ENERGY USAGE IN BUILDINGS

## Issues and opportunities

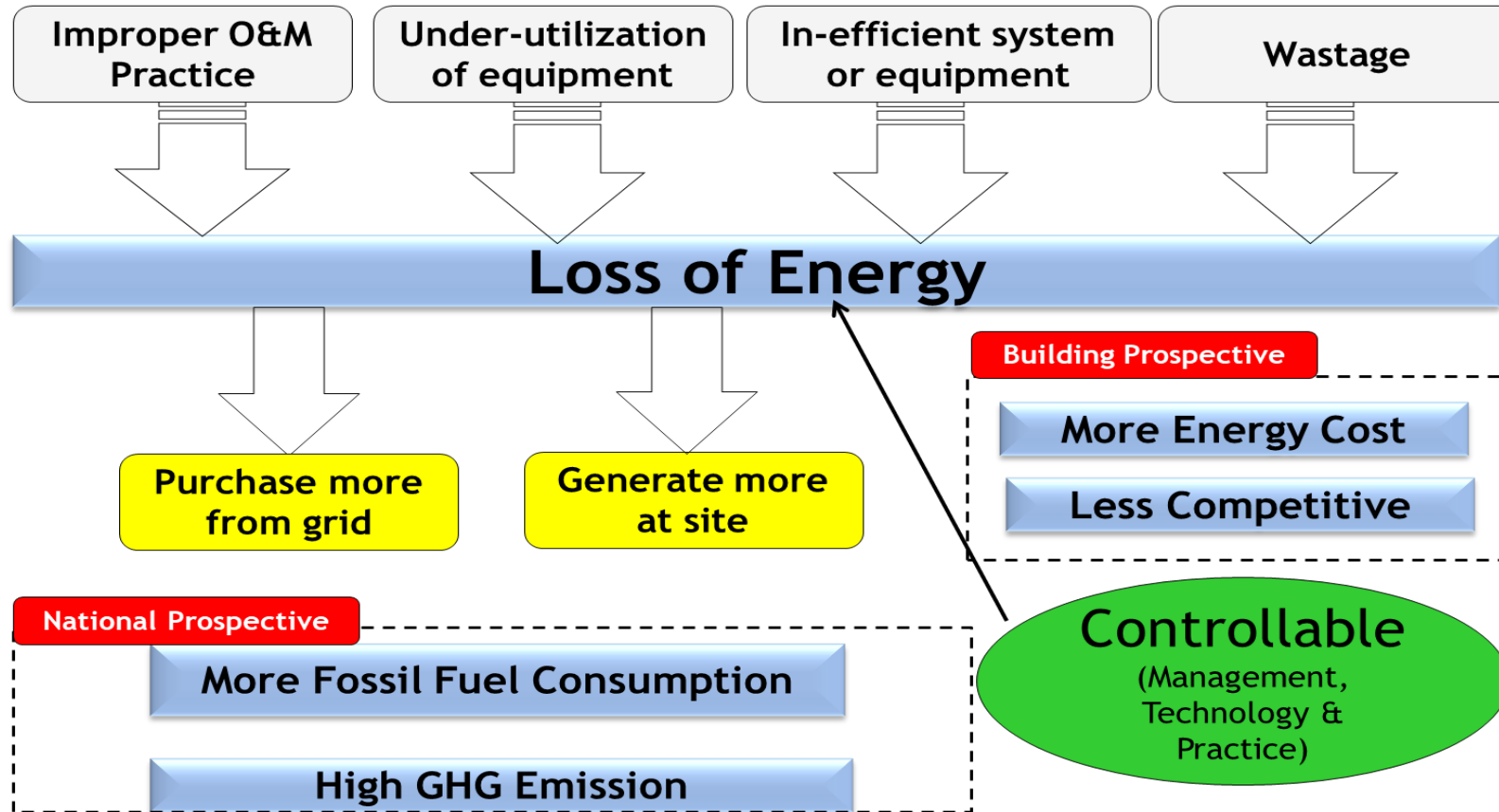

# TYPICAL ENERGY SNAPSHOT

Example: Hotel building in Chiang Mai, Thailand

Location	:	Chaing Mai, Thailand
Building	:	5-Star, 5 Floors
Building Type	:	Resort
Hotel Area	:	12,825 m <sup>2</sup>
Source of Supply	:	22 KV from Authority Own Generation from DG Sets
Transformers	:	2 x 800 KVA
DG Sets	:	1 x 500 KVA
Major Electrical Loads	:	Lighting and Power, Air Conditioning, Water Pumping, Hot Water Generator
Estimated Connected Load	:	About 667 KW
Usage Hours	:	24 Hrs Operation
Air Conditioning System	:	Non-central AC
Annual Energy Consumption	:	344 Tons of Oil Equivalent
Annual Electricity Consumption	:	1.8 million kWh
Annual Energy Cost	:	THB 11.4 million

# COMMERCIAL BUILDINGS

## Typical energy consumption in commercial buildings

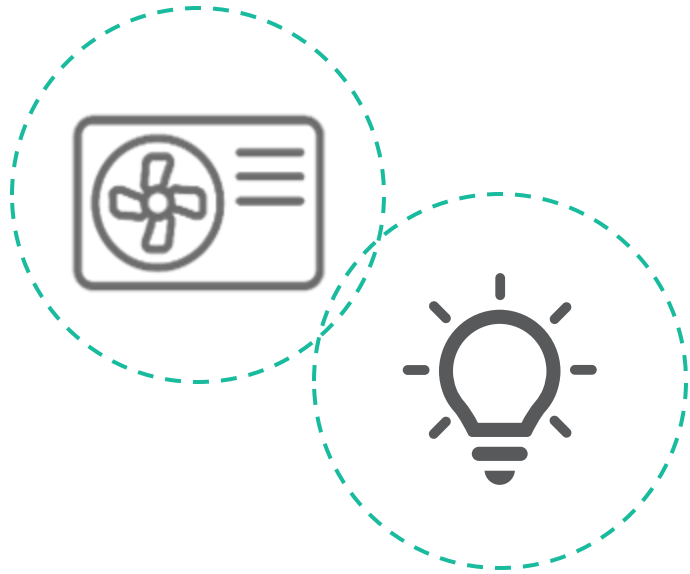

Air conditioning and lighting are the major focus area for energy management in buildings

Breakdown of energy consumption in a typical air-conditioned commercial building; note the contribution of heat load from various heat sources on the HVAC system; building envelope is usually the major contributor.

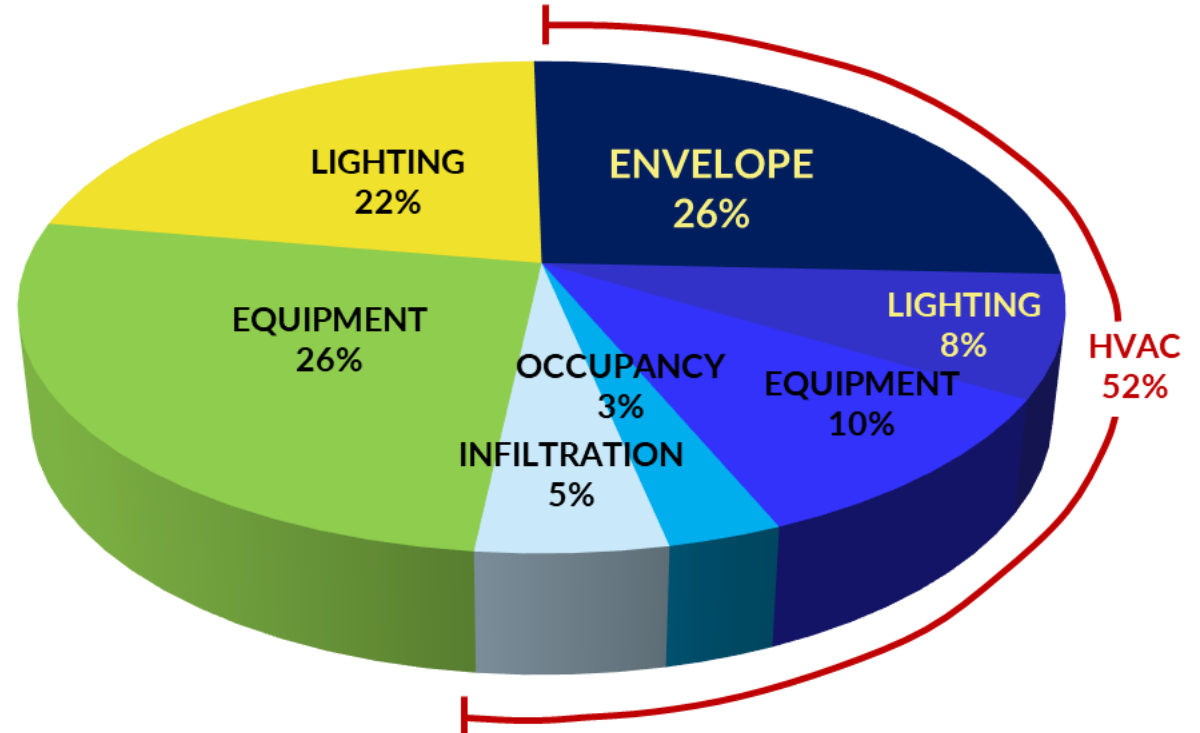

Source: Farheen Bano & Mohammad Arif Kamal. 2016. Examining the Role of Building Envelope for Energy Efficiency in Office Buildings in India. Architecture Research 2016.

# TYPICAL INVENTORY ANALYSIS

Example: Share of connected load and energy consumption in a commercial building

Load Centers	Connected Load kW	Annual Energy Consumption, kWh
Air Conditioning	360	460,800
Lighting	104	566,734
Water Pumping	42	182,953
Others	162	591,886
<b>Total</b>	<b>667</b>	<b>1,802,372</b>

**Connected Load**  
**670 kW**

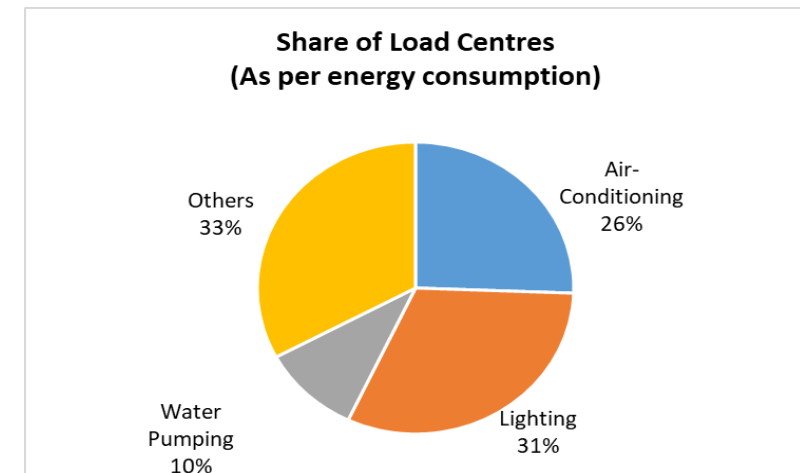
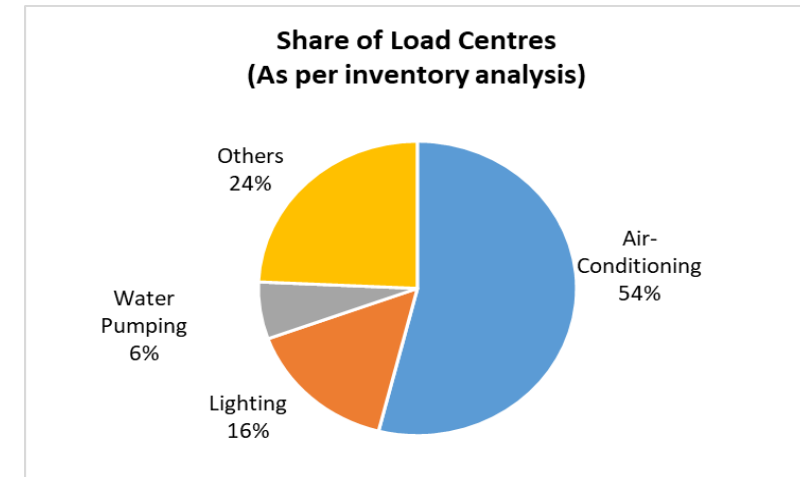

# TYPICAL LOAD CURVE

Example: Monthly electrical energy usage pattern in commercial buildings

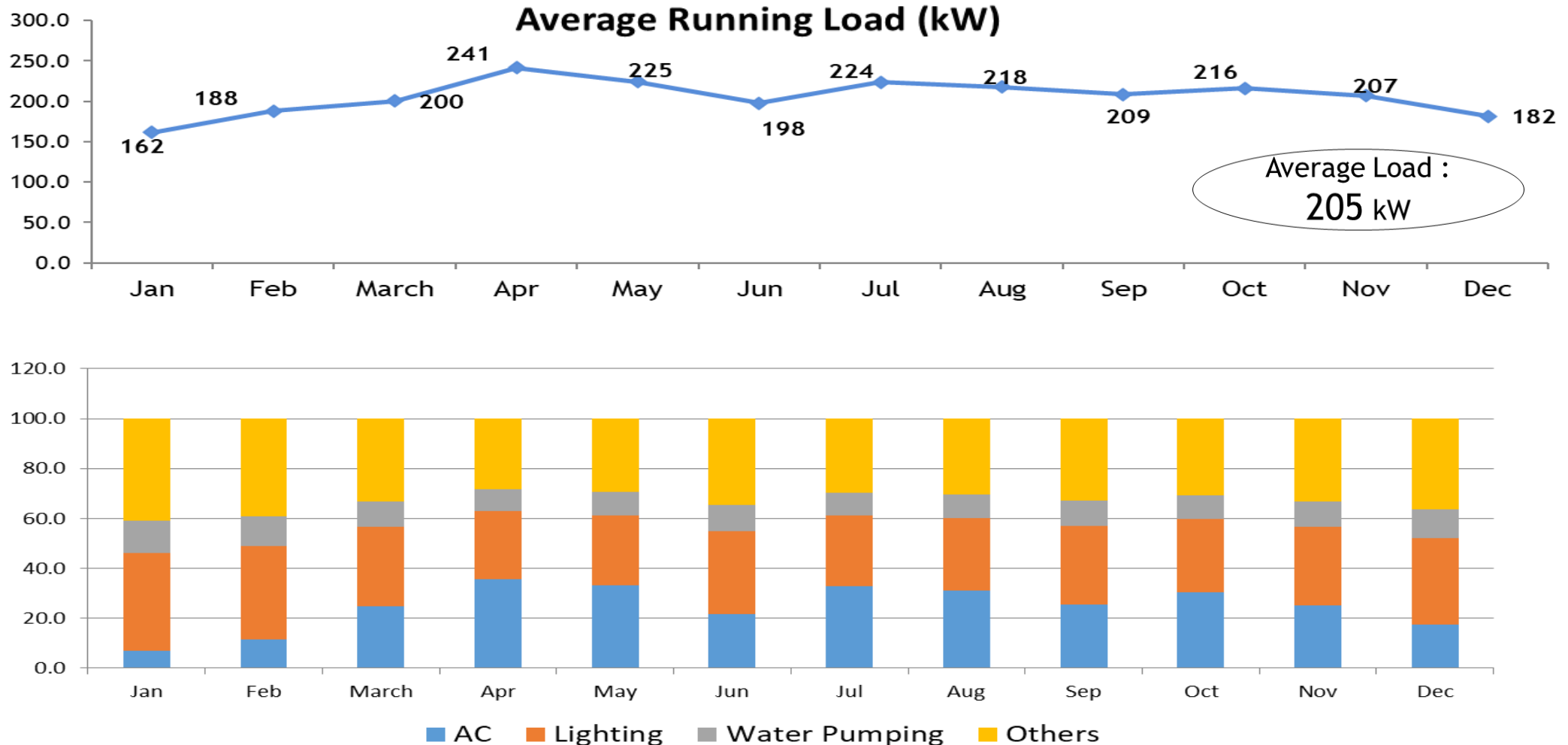

# HVAC – EXAMPLE OF HEAT GAIN

Building envelope: Sources of heat load on HVAC in different climatic zones in India

Heat Gain through Building Envelope (Ground + 4 floors Office Building)								
Climate	Hot and Dry		Warm and Humid		Composite (Hot and Dry, Warm and Humid, Cold)		Composite (Hot and Dry, Warm and Humid, Cold)	
Building Component	Ahmedabad (223.037 MWh)		Mumbai (201.892 MWh)		Nagpur (198.756 MWh)		Pune (137.764 MWh)	
	Cooling Load (MWh)	Annual Cooling Load (%)	Cooling Load (MWh)	Annual Cooling Load (%)	Cooling Load (MWh)	Annual Cooling Load (%)	Cooling Load (MWh)	Annual Cooling Load (%)
Walls	81.141	36.4	66.532	33.0	71.151	35.8	36.487	26.5
Roof	18.996	8.5	15.148	7.5	17.845	9.0	12.288	8.9
Ground	4.957	2.2	4.557	2.3	3.000	1.5	0.129	0.1
Window (Conduction + Direct Solar)	117.941 (28.563 + 89.378)	52.9 (12.8 + 40.1)	115.654 (17.405 + 98.249)	57.3 (8.6 + 48.7)	106.761 (19.608 + 87.153)	53.7 (9.9 + 43.8)	89.119 (6.180 + 82.939)	64.7 (4.5 + 60.2)

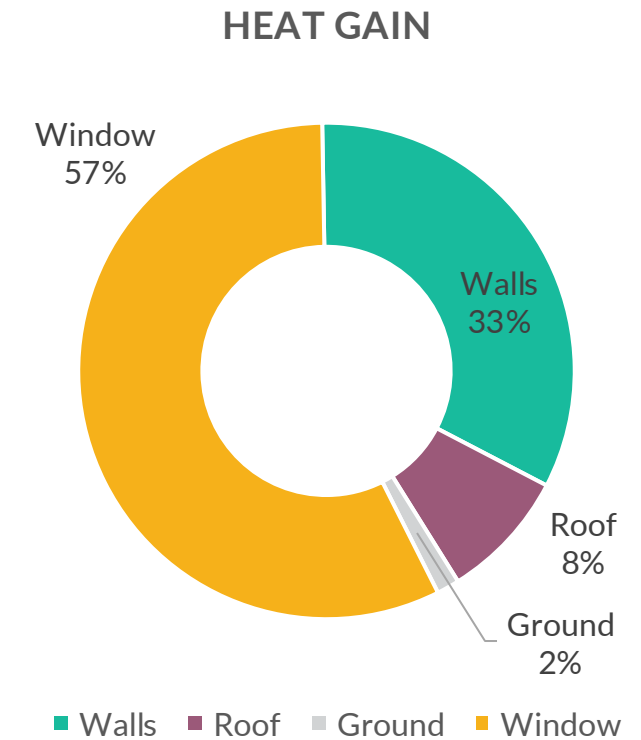

Source: Farheen Bano & Mohammad Arif Kamal. 2016. Examining the Role of Building Envelope for Energy Efficiency in Office Buildings in India. Architecture Research 2016.

# HOTELS AND RESORTS

India: Estimated Energy Performance Index (EPI)

Category	Built-up Area m <sup>2</sup> /room	EPI kWh/m <sup>2</sup> /year	EPI kWh/room/year
1 Star	30–35	55–82.5	1,650–2,888
2 Star	35–40	110–137.5	3,850–5,500
3 Star	50–60	137.5–165	6,875–9,900
4 Star	60–70	165–192.5	9,900–13,475
5 Star	70–80	192.5–220	13,475–17,600
Heritage	80–90	220–247.5	17,600–22,275
Others	–	82.5–110	

Source: Kumar et al., 2017

# HOSPITALS

India: Estimated Energy Performance Index (EPI)

Category	Built-up Area m <sup>2</sup> /bed	EPI kWh/m <sup>2</sup> /year	EPI kWh/bed/year
Government - Urban	50-60	110-165	5,500-9,900
Government - Rural	35-42	44-55	1,540-2,310
Private - All	70-80	165-220	11,550-17,600

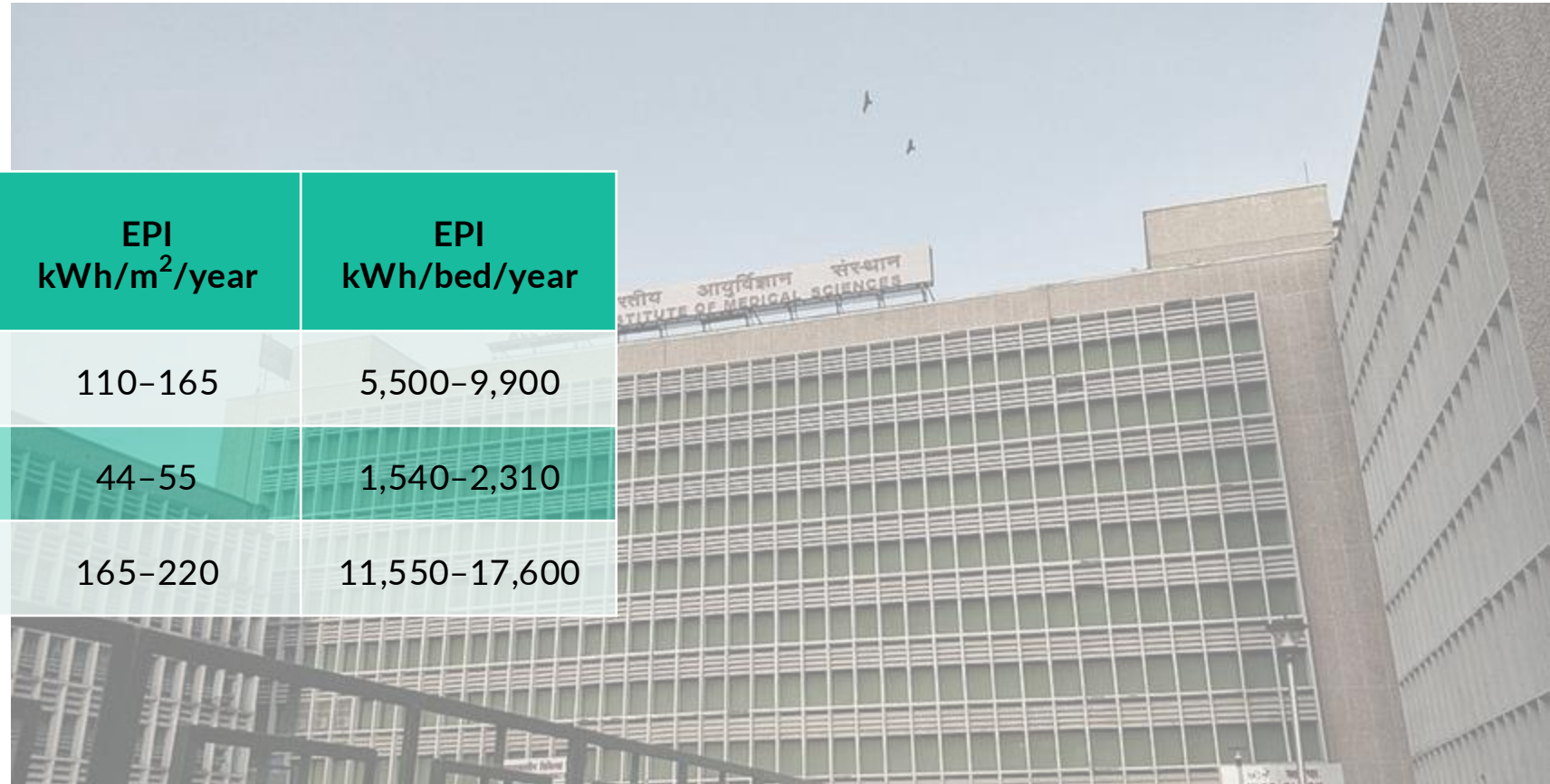

Source: Kumar et al., 2017

Image source: Vishnoi

# OFFICE BUILDINGS

India: Estimated Energy Performance Index (EPI)

Category	Built-up Area m <sup>2</sup> /employee	EPI kWh/m <sup>2</sup> /year	EPI kWh/employee/year
<b>PRIVATE OFFICES</b>			
Information Technology-enabled Services	9–11	82.5–110	743–1,210
Banking Services, Finance and Insurance	6–8	55–82.5	330–660
<b>PUBLIC OFFICES</b>			
Central Government	12–15	77–99	924–1,485
State Government	10–12	66–77	660–924
Quasi Government	8–10	77–88	616–880
Local Government	3–5	22–33	66–165

Source: Kumar et al., 2017

# EDUCATION BUILDINGS

India: Estimated Energy Performance Index (EPI)

Category	Built-up Area m <sup>2</sup> /building	EPI kWh/m <sup>2</sup> /year
<b>SCHOOLS</b>		
Primary	150–160	20–25
Upper Primary	301–310	20–25
Secondary	554–560	30–40
Higher Secondary	1,313–1,320	30–40
<b>UNIVERSITIES / COLLEGES</b>		
Rural	1,500–2,000	22–27.5
Urban	2,000–2,500	33–44
Institutes of National Importance	20,000–25,000	44–55
Stand-alone Institutions	500–600	22–33



Source: Kumar et al., 2017

Image sources: Deannadamon; AjZock

# RETAIL

## India: Estimated Energy Performance Index (EPI)

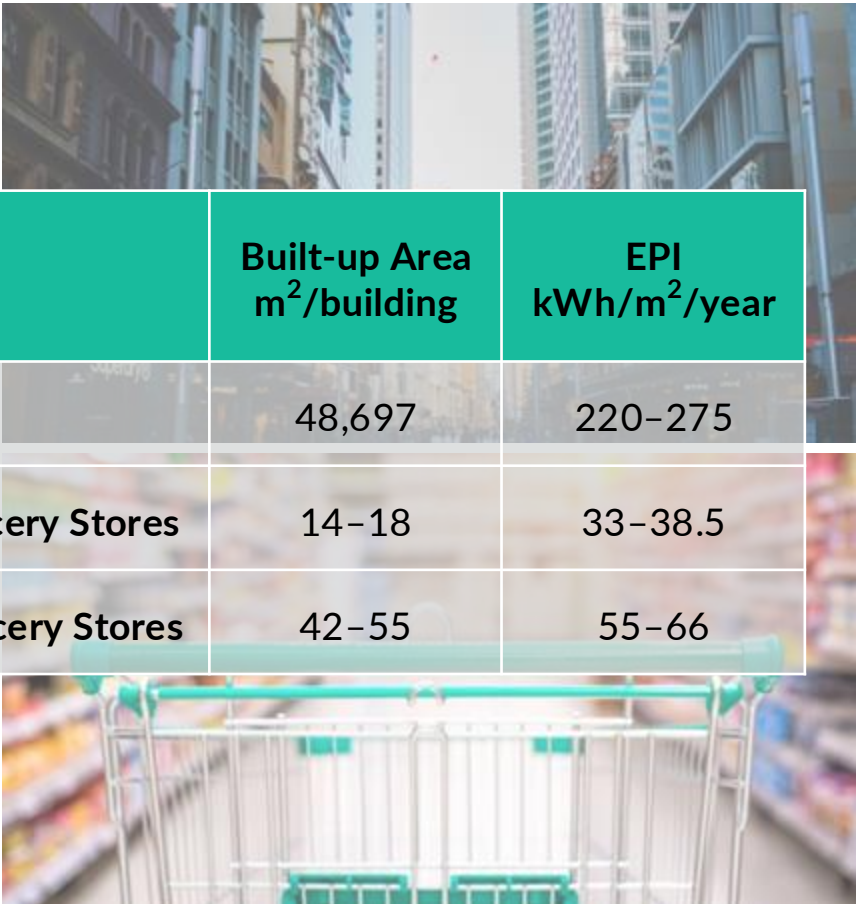

Category	Built-up Area m <sup>2</sup> /building	EPI kWh/m <sup>2</sup> /year
Modern Malls	48,697	220–275
Traditional Small Grocery Stores	14–18	33–38.5
Traditional Large Grocery Stores	42–55	55–66

Source: Kumar et al., 2017

# INDIA: STAR RATING THRESHOLDS

## Business process outsourcing (BPO) buildings

Climatic Zone		1 Star	2 Star	3 Star	4 Star	5 Star
Composite	Threshold EPI (y)	$y = 0.21x + 28$	$y = 0.18x + 24$	$y = 0.15x + 20$	$y = 0.12x + 16$	$y = 0.09x + 12$
	Calculated EPI Value	41.7	35.7	29.8	23.8	17.9
Hot and Dry	Threshold EPI (y)	$y = 0.1x + 24$	$y = 0.08x + 20$	$y = 0.06x + 16$	$y = 0.04x + 12$	$y = 0.02x + 8$
	Calculated EPI Value	30.5	25.2	19.9	14.6	9.3
Warm and Humid	Threshold EPI (y)	$y = 0.17x + 36$	$y = 0.14x + 32$	$y = 0.11x + 28$	$y = 0.08x + 24$	$y = 0.05x + 20$
	Calculated EPI Value	47.05	41.1	35.2	29.2	23.3
Temperate	Threshold EPI (y)	$y = 0.13x + 31$	$y = 0.11x + 27$	$y = 0.09x + 23$	$y = 0.07x + 19$	$y = 0.05x + 15$
	Calculated EPI Value	39.45	34.2	28.9	23.55	18.3

**Notes:** 'x' is air-conditioned floor area as a percentage of total floor area

'y' is threshold Energy Performance Index (EPI)

Sample EPI calculated values are provided for air-conditioned area @ 65% of total floor area

EPI values of buildings must be below the threshold value to qualify for star rating

Energy generated from onsite renewable energy sources is excluded from EPI calculation

Source: Bureau of Energy Efficiency, Government of India, 2023b

# INDIA: STAR RATING THRESHOLDS

## Office buildings

Climatic Zone	Building Category	1 Star	2 Star	3 Star	4 Star	5 Star
Composite	Large Office Calculated EPI Value	$y = 0.95x + 60$ 121.75	$y = 0.9x + 50$ 108.50	$y = 0.85x + 40$ 95.25	$y = 0.8x + 30$ 82.00	$y = 0.75x + 20$ 68.75
	Medium Office Calculated EPI Value	$y = 1.1x + 60$ 131.50	$y = 1.05x + 50$ 118.25	$y = 1.0x + 40$ 105.00	$y = 0.95x + 30$ 91.75	$y = 0.9x + 20$ 78.50
	Small Office Calculated EPI Value	$y = 0.65x + 60$ 102.25	$y = 0.6x + 50$ 89.00	$y = 0.55x + 40$ 75.75	$y = 0.5x + 30$ 62.50	$y = 0.45x + 20$ 49.25
Warm and Humid	Large Office Calculated EPI Value	$y = 0.9x + 65$ 123.50	$y = 0.85x + 55$ 110.25	$y = 0.8x + 45$ 97.00	$y = 0.75x + 35$ 83.75	$y = 0.7x + 25$ 70.50
	Medium Office Calculated EPI Value	$y = 0.9x + 65$ 123.50	$y = 0.85x + 55$ 110.25	$y = 0.8x + 45$ 97.00	$y = 0.75x + 35$ 83.75	$y = 0.7x + 25$ 70.50
	Small Office Calculated EPI Value	$y = 0.7x + 65$ 110.50	$y = 0.65x + 55$ 97.25	$y = 0.6x + 45$ 84.00	$y = 0.55x + 35$ 70.75	$y = 0.5x + 25$ 57.50
Hot and Dry	Large Office Calculated EPI Value	$y = 1.1x + 55$ 126.50	$y = 1.05x + 45$ 113.25	$y = 1.0x + 35$ 100.00	$y = 0.95x + 25$ 86.75	$y = 0.9x + 15$ 73.50
	Medium Office Calculated EPI Value	$y = 1.25x + 55$ 136.25	$y = 1.2x + 45$ 123.00	$y = 1.15x + 35$ 109.75	$y = 1.1x + 25$ 96.50	$y = 1.05x + 15$ 83.25
	Small Office Calculated EPI Value	$y = 0.75x + 55$ 103.75	$y = 0.7x + 45$ 90.50	$y = 0.65x + 35$ 77.25	$y = 0.6x + 25$ 64.00	$y = 0.55x + 15$ 50.75

Notes: 'x' is air-conditioned floor area as a percentage of total floor area

'y' is threshold Energy Performance Index (EPI)

Sample EPI calculated values are provided for air-conditioned area @ 75% of total floor area, 8–9 hours operation for 6 days/week

EPI values of buildings must be below the threshold value to qualify for star rating

Energy generated from onsite renewable energy sources is excluded from EPI calculation

Source: Bureau of Energy Efficiency, Government of India, 2023b

# INDIA: STAR RATING THRESHOLDS

Ranking for hospitals with more than 50% air-conditioned space

	5 Star	4 Star	3 Star	2 Star	1 Star	No Star
Performance Rank	$\leq 4$	$> 4$ and $\leq 12$	$> 12$ and $\leq 24$	$> 24$ and $\leq 40$	$> 40$ and $\leq 60$	$> 60$ and $\leq 100$

*Note: Energy generated from onsite renewable energy sources is excluded from energy calculation*

- The ranking methodology compares the energy consumption of a hospital with its benchmark value'
- The benchmark value represents the average energy consumption of hospitals with similar characteristics and is derived from sample data, using regression analysis
- The ratio of the actual energy consumption of a hospital to its benchmark value depicts the relative energy efficiency of the building
- A performance rank is derived by comparing this ratio to a distribution derived from the sample data set
- The performance rank lies in the range of 1–100. A rank of 1 implies performance among the top 1% hospital buildings in the nation, while a rank of 50 represents an average performance. The star rating is based on the rank

*Source: Bureau of Energy Efficiency, Government of India, 2023b*

# INDIA: STAR RATING THRESHOLDS

## Shopping malls



Composite Climate	
EPI (kWh/m <sup>2</sup> /year)	Star Label
350-300	1 Star
300-250	2 Star
250-200	3 Star
200-150	4 Star
Below 150	5 Star



Temperate Climate	
EPI (kWh/m <sup>2</sup> /year)	Star Label
275-250	1 Star
250-225	2 Star
225-200	3 Star
200-175	4 Star
Below 175	5 Star



Hot and Dry Climate	
EPI (kWh/m <sup>2</sup> /year)	Star Label
300-250	1 Star
250-200	2 Star
200-150	3 Star
150-100	4 Star
Below 100	5 Star



Warm and Humid Climate	
EPI (kWh/m <sup>2</sup> /year)	Star Label
450-400	1 Star
400-350	2 Star
350-300	3 Star
300-250	4 Star
Below 250	5 Star

**Note: Energy generated from onsite renewable energy sources is excluded from energy calculation**

Source: Bureau of Energy Efficiency, Government of India, 2011

# ENERGY MANAGEMENT

Genesis from the perspective of a building energy manager

- I should know my energy usage pattern
- I should know where I stand in comparison with other similar building(s)
- I should know the potential areas of energy saving
- My staff should manage energy in an efficient and sustainable manner
- I should be aware of the options for improving energy performance
- I should work toward continuous improvement of energy performance

**Benchmarking**

**Data Monitoring**

**Energy Audit**

**Guidebook &  
Training**

# ENERGY MANAGEMENT

## Understanding major loads in buildings

- In modern buildings, building cooling accounts for 50%–70% of total energy consumption, and lighting accounts for about 10%–20% of total energy consumption. The contribution to the HVAC heat load due to people and appliances vary significantly, depending on type of building i.e., office, hotel, hospital, BPO building, educational institution, etc.
- In naturally-ventilated buildings without air conditioning, ceiling fans may account for a significant portion of energy consumption
- The major energy saving potential is expected to be in building cooling and lighting. A holistic systems approach is recommended wherein opportunities for reduction in air conditioning and lighting load are addressed first, before focusing on equipment energy efficiencies

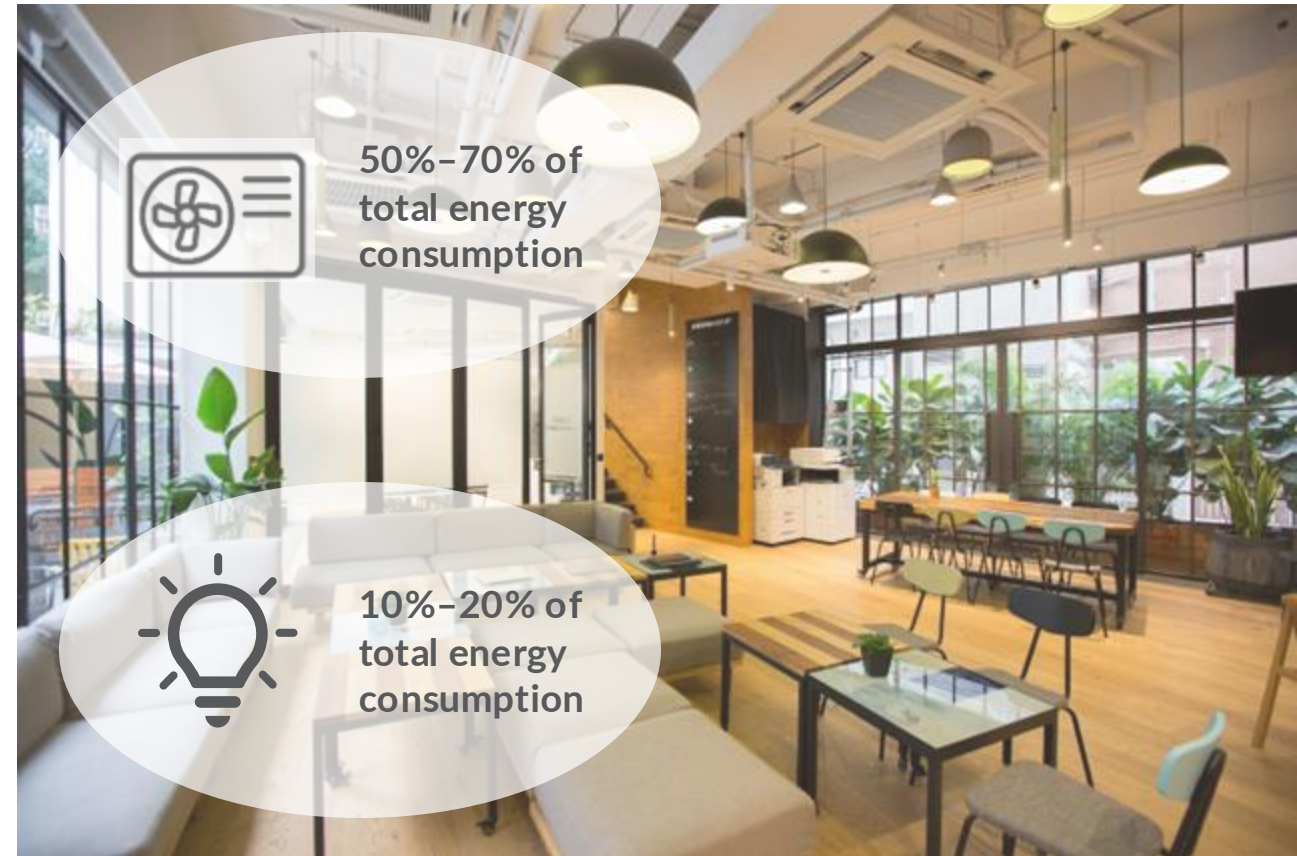

# ENERGY MANAGEMENT

## Holistic approach to energy savings in building cooling

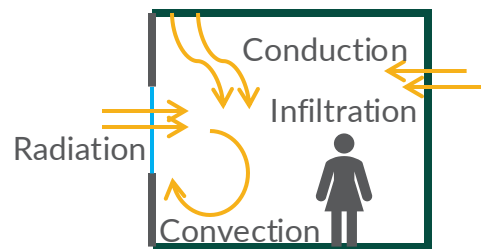

- Use principles of adaptive thermal comfort to vary HVAC temperature settings in relation to outside air temperatures and humidity

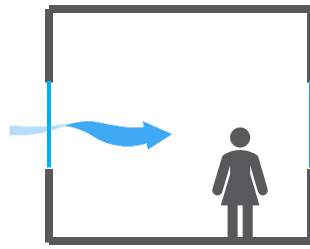

- Consider increasing convective air movement in rooms by providing low-speed fans to enable comfort at higher room temperature settings

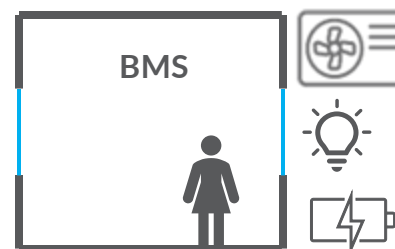

- Consider increasing temperature settings of rooms without occupancy like unoccupied cabins, guest rooms, conference rooms, low occupancy foyers, document storage rooms, reprographics rooms, etc.
- Good control systems should be in place in the hydronic and air handling units (AHUs) or fan coil units (FCUs) to achieve higher temperature settings without the dripping of excessive water condensation, especially in FCUs
- A centralized building management system (BMS) with occupancy sensors is required for effective monitoring and control

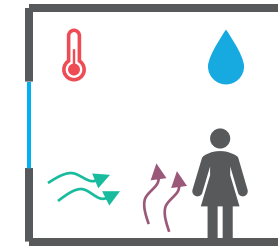

Temperature  
Humidity  
Airflow  
Radiant Heat

- In most HVAC systems, the recirculating air quantity may be about 90% and the ventilation fresh air quantity about 10%
- Cooling has two components: (i) sensible heat removal by reduction of air temperature; and (ii) latent heat removal, which is heat removal due to condensation of moisture that helps in maintaining the room's relative humidity at a comfortable 50% to 60%
- Moisture is usually from two main sources: fresh air and gaseous bio-effluents from people (sweat, exhaled air, etc.)
- To ensure condensation of moisture, the air temperature has to be brought below dew point temperature of air

# ENERGY MANAGEMENT

## Holistic approach to energy savings in building cooling

- In conventional HVAC systems, the temperature of the entire recirculating and fresh air quantity is brought down to a low temperature, implying that along with moisture removal, the sensible cooling load also increases significantly, as the entire recirculating air quantity is brought down to a low temperature. Consider using a dedicated outside air system (DOAS) for removal of humidity from the fresh air at source with direct refrigerant cooled coil or desiccant wheel; this can enable temperature reset to higher temperature in the main air handling units, which are handling the large recirculating air quantity
- In the case of fixed speed chillers, monitoring of refrigeration load on chillers is essential to ensure that, to the extent possible, chillers are operating above 80% of the rated load to ensure operation close to the design COP
- In the case of variable speed chillers, operation at lower speeds increases the COP. In the case of fixed speed chillers, the improvement in COP may or may not be significant, depending on the capacity control method. There are no general rules, hence, the optimal trade-off between operating more chillers at lower load and additional auxiliary pumps should be established for each system and programmed into the operating control
- Operating COP of chillers should be established at normal loading. The performance should be correlated with chiller loading, logarithmic mean temperature differences (LMTD) in the evaporator and condenser, chilled water or cooling water flow rates in the chiller and condenser, water-side pressure drops across the evaporator and condenser, and refrigerant charge. Higher LMTDs may be an indication of fouling of evaporator and/or condenser; it may also be an indication of insufficient heat transfer area

# ENERGY MANAGEMENT

## Holistic approach to energy savings in building cooling (continued)

- Practical experience from energy audits indicates that the drop in efficiency of chillers are usually due to fixed speed compressors operating at partial loads or due to poor heat transfer in the evaporator and condenser; poor performance is rarely due to mechanical problem with the compressor
- Fouling of evaporators and condensers must be addressed through mechanical cleaning, retrofitting with in-line cleaning systems or resolving any chronic water quality issues
- In case the evaporator and condenser heat transfer areas are insufficient, replacement of these heat exchangers may be required to improve chiller efficiency
- The performance of chilled water pumps and cooling water pumps should be critically evaluated from the viewpoint of operating flow, pressure and operating efficiency; opportunities usually exist for optimization of flows, pressures and pump efficiencies. The operating head and flow should closely align with the pump's design head and flow within the optimal efficiency zone to ensure maximum pumping power
- Cooling tower performance impacts chiller operating efficiency. One of the critical parameters is ratio of water flow -to- air flow (L/G ratio). Insufficient heat transfer area, fouling of cooling tower and low air flow result in inefficient operation of chillers

# ENERGY MANAGEMENT

## Holistic approach to energy savings in building cooling (continued)

- Air flows in air-cooled condensers are difficult to measure under site conditions, but refrigerant condensing pressures and cooling air temperatures can provide guiding indicators for the performance and impact on chiller efficiency. Retrofitting evaporative coolers to reduce condensing pressure and temperature during high ambient dry bulb temperature (with low relative humidity) is an effective method to improve chiller efficiency
- Performance assessment of large AHU centrifugal fans needs critical review. Replacement of inefficient fans with energy efficient axial flow fans with permanent magnet and brushless direct current (BLDC) motors (the combination is popularly called EC fans in India) has energy saving potential in the range of 20% - 30%, depending on the existing efficiencies of fans and motors
- All large AHUs should have variable speed drives to optimize air flow, while multi-speed motors are recommended for FCUs. For effective, trouble-free operation, each AHU or FCU should have proper controls for throttling and bypassing chilled water at lower air flows
- A good BMS is required wherein the cooling load of buildings and that of large areas are monitored by integration of chilled water temperatures and flows, and correlating them with energy consumption

# ENERGY MANAGEMENT

## Holistic approach to energy savings in lighting

- In the past decade, the widespread availability and reduction in prices of energy efficient LED lamps have led to their widespread use across various applications, from bedside lamps to flood lighting in sports stadiums. Available in a range of wattages and offering numerous designs variations in lamps and luminaires, the primary driver has been aesthetics. As a result, there may be limited scope for energy optimization through the replacement of lamps and luminaires, as was the case with conventional gas discharge lamps and luminaires
- Due to the reduced energy consumption in lighting due to LED lamps, it is often difficult to justify investments in dedicated control systems only for lighting. However, it makes economic sense if it is part of a BMS that also controls HVAC

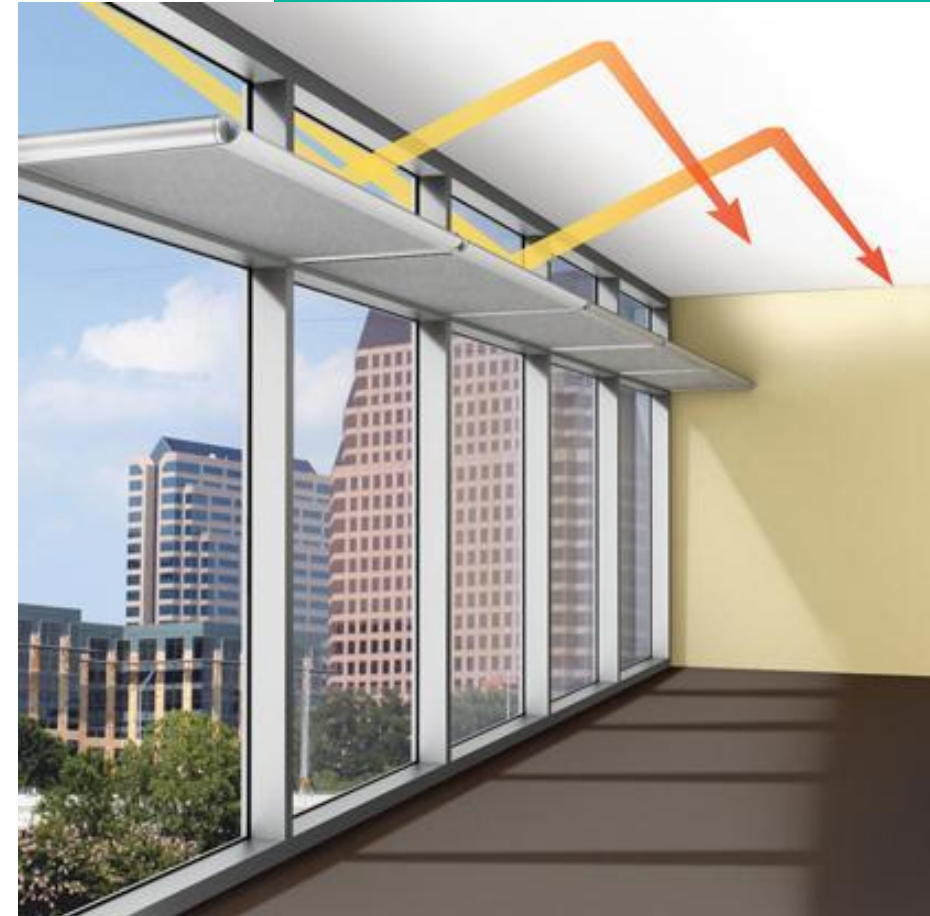
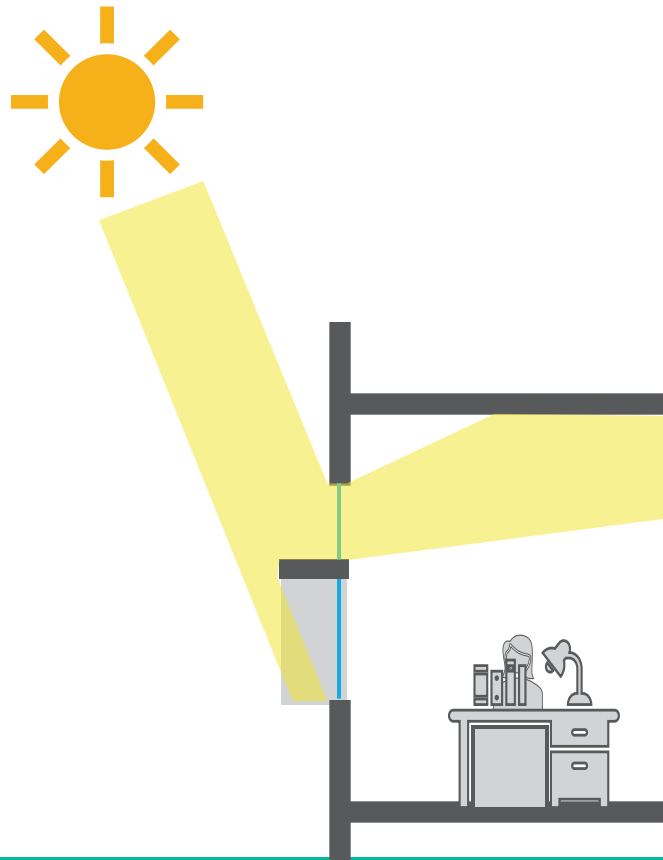

Image source: Wipro Lighting

# ENERGY MANAGEMENT

## Holistic approach to energy savings in lighting (continued)

- However, energy saving opportunities still exist for optimizing the use of electric lights during daytime. Although excessive glass is used in modern buildings for aesthetics, most buildings still use electric lighting during daytime
- In most buildings, due to glare or excessive light and solar radiation, occupants usually prefer to draw the blinds and use electric lights
- The absence of light shelves to allow natural light without glare in building architectural design augments the problem. However, possibilities exist to innovatively and aesthetically retrofit light shelves in existing buildings to reduce daytime use of electric lighting



**Retrofitting light shelves**

Image source: [https://www.designingbuildings.co.uk/wiki/Light\\_shelf](https://www.designingbuildings.co.uk/wiki/Light_shelf)

# ENERGY MANAGEMENT

## Integration of renewable energy

- The goal of net zero buildings cannot be achieved by energy efficiency measures alone. Integration of renewable energy with grid energy systems is required
- The simplest way forward is to source renewable electrical power from solar power plants or wind farms through offsite generation, although it may be more expensive if it is sourced from independent power producers
- Sizing of onsite solar power systems depends on space availability and matching electrical load availability during sunshine hours
- Onsite generation of solar power may give greater operational energy savings but will involve high initial capital cost
- Ideally, the solar power system should be sized to meet the building's entire energy demand, as the greatest cost savings are likely achieved when expensive grid electricity is offset. Exporting solar power typically reduces the return on capital investment, as the revenue from exported power is usually much lower than the cost of imported grid electricity



# ENERGY MANAGEMENT

## Integration of renewable energy (continued)

- Technical issues related to the electrical power system require attention, especially the point of connection to the power system. It is desirable for the solar power system to be connected on the upstream side of the main automatic power factor controller (APFC) to avoid malfunction in power factor control if the power is not fully absorbed in the building and power is exported. Most passive power factor controllers are designed to operate in power export mode
- Fixed charges of grid power should be factored in the calculations of economics of solar power systems, as higher contracted grid power is required for overcast days and nights. Operation with low margins of contracted power may demand automated electrical power management systems with non-critical load shedding capability
- The integration of wind power is usually from offsite wind farms. This is because the power capacities of onsite wind turbines are generally too small and dependent on highly unpredictable wind velocities, and hence, not popular
- The integration of thermal renewable energy in the form of solar hot water systems or biomass fired systems can be easily integrated and do not have the complications associated with electrical power integration



# OFFICE BUILDING

Case example: Large office building in the IT/ITES sector

- Capgemini's EPIP Campus in Bengaluru, India, is the first information technology (IT) and information technology-enabled services campus in India to achieve the Net Zero Energy - Platinum (Operation) certification from IGBC
- The project team worked for almost three years to explore new and innovative measures for energy efficiency and retrofit old equipment to industry-benchmarked high performing equipment and systems. They included water-cooled chillers, inline primary pumps integrated with VFD, AHUs fitted with EC motors and ESP filters along with UVGI lamps, LED lighting fixtures, and integrated solar lighting fixtures for exterior illumination and street lighting
- Additionally, the project produces onsite renewable energy (over 20%) and imports green power to offset 100% grid energy use by renewables



Capgemini's EPIP Campus in Bengaluru, India

Source: Confederation of Indian Industry and Shakti Sustainable Energy Foundation, 2022

# OFFICE BUILDING

## Case example: Large office building in the IT/ITES sector (continued)

The integration of renewable energy:

- Significant increase in onsite renewable energy generation (1.35 MWp)
- Source about 78%–80% green power through purchase power agreement
- Installation of 100% solar-based street lighting
- Use of solar-powered chiller for maximum reduction in energy demand

Other measure include:

- Reduction in data center energy consumption by retro-commissioning, retrofitting, and managing hot and cold aisle containment and sophisticated control of cool air
- Rigorous metering and monitoring of energy at end use. It includes the monitoring of each equipment on real-time basis (at 15-minute intervals) and diagnose performance with respect to rated capacity and energy consumption
- Inferred decisions from online management system. It includes a central command center to map out energy usage and create alarms when performance deviates from design goals

These implementations reduced energy use of the facility by 16%. The Energy Performance Index ratio of the campus is 0.73

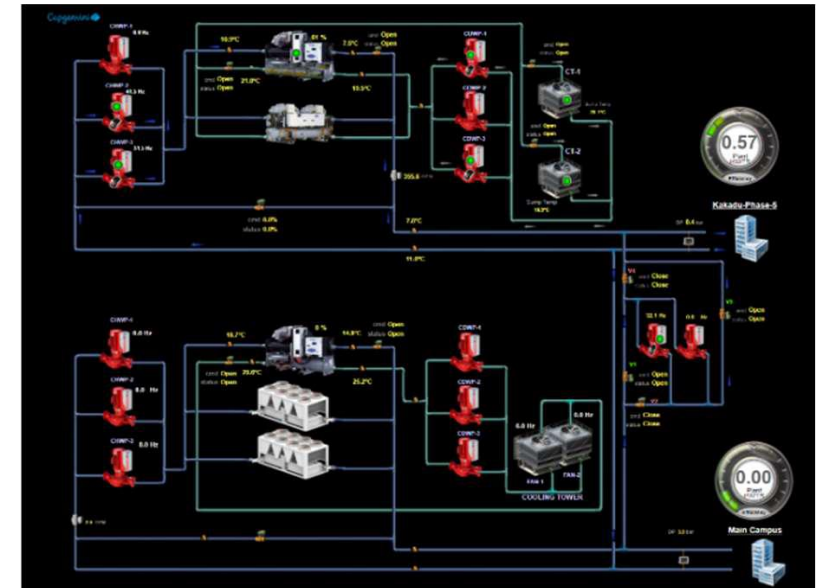

Source: Confederation of Indian Industry and Shakti Sustainable Energy Foundation, 2022

# HOSPITAL BUILDING

## Case example: Design interventions to improve EPI

A 350-bed multi-specialty hospital building in warm-humid climate (Pune, India) implemented measures for improving the Energy Performance Index (EPI) at the design stage; the main focus being on HVAC

The built-up area is 26,580 m<sup>2</sup> (excluding parking and service floor: ~9,500 m<sup>2</sup>), with 3 underground floors and 9 overground floors + 1 service floor. The types of spaces include technical areas like MRI, ICUs, Cath lab, OTs; patient indoor rooms and recovery rooms; restaurants, emergency rooms, etc.

The measures implemented for the building envelope were:

- Roof insulation: 150mm of RCC roof slab was insulated with 100mm extruded polystyrene (XPS) which gives a U-value of 0.31 W/m<sup>2</sup>.K
- External wall: External walls were made of 150mm AAC block with plaster on both sides, resulting in a U-value of 0.9 W/m<sup>2</sup>.K
- Glazing: The project team emphasized the importance of daylight in faster recovery of patients and clear glass was selected. Double glazed units were selected for a lower U-value of 2.8 W/m<sup>2</sup>.K



A multi-specialty hospital in Pune, India

Source: Bhanware et al., 2020

# HOSPITAL BUILDING

## Case example: Design interventions to improve EPI (continued)

The measures implemented for the HVAC system were:

- Use of dynamic energy simulation software for chiller plant sizing instead of simplified calculation based on static design conditions. Installed chiller capacity is 560 TR (280 x 3 [2 working + 1 standby])
- Selection of a high efficiency chiller with a COP of 5.92 and very good part load performance (NPLV: 0.367)
- Integration of enthalpy recovery wheels in fresh air AHUs with 75% effectiveness for both latent and sensible heat recovery
- Use of condenser water for reheating the air in AHUs to maintain relative humidity. Backup hot water is provided by a heat pump system with a COP of 2.81
- Provisions for free cooling on patient floors, which means if the outside air is suitable for space cooling, it can directly be supplied without passing through the cooling coil

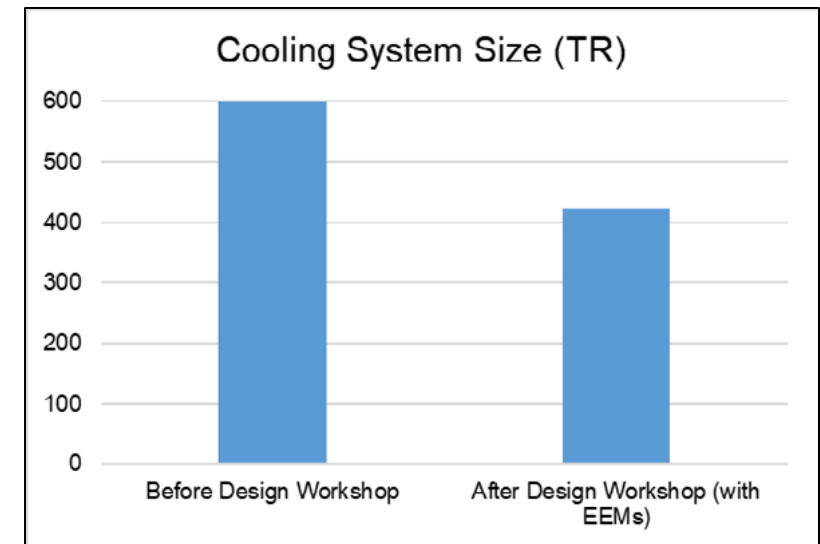

**A multi- speciality hospital in Pune, India**

# HOSPITAL BUILDING

## Case example: Design interventions to improve EPI (continued)

The system sizing calculation was done using HAP software and energy simulation of the building was conducted using DesignBuilder software to quantify the benefits of the integration of energy efficiency measures. The key results of the energy simulation were:

- Reduction in cooling system size – The cooling system size was reduced from 600 TR (before the design workshop) to 424 TR (after the integration), a 29% reduction in size
- Reduction in energy consumption – The Energy Performance Index (EPI) was reduced from 154 kWh/m<sup>2</sup>.y to 130 kWh/m<sup>2</sup>.y (16% reduction) after considering energy efficiency measures in energy simulation

The actual EPI achieved by the hospital was 136 kWh/m<sup>2</sup>.y, which was very close to the predicted performance of 130 kWh/m<sup>2</sup>.y. The hospital received a 4-star rating under BEE star rating for hospitals

Subsequently, operational improvements, namely, increasing chilled water generation temperature, reducing condenser water temperature, change in heat pump control, etc. were implemented, which resulted in approximately additional 10% energy saving

Source: Bhanware et al., 2020

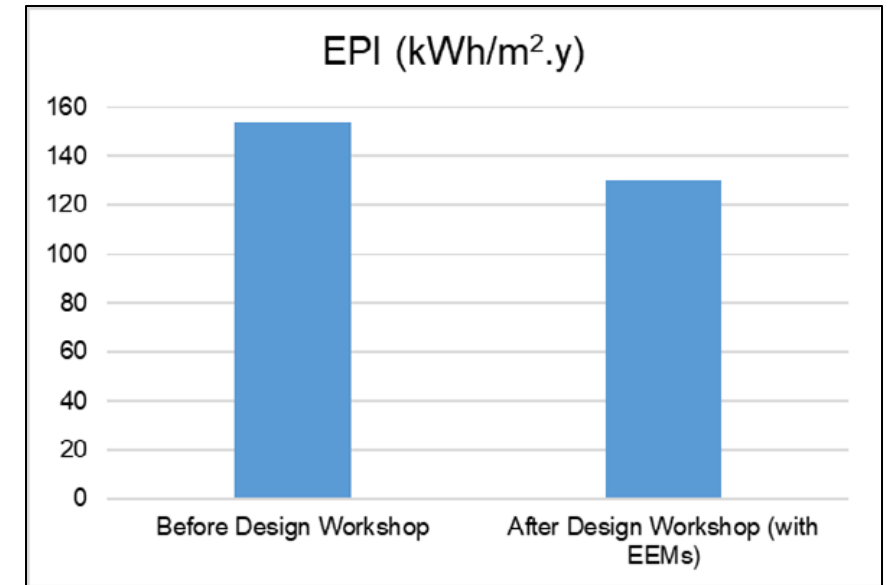

**A multi- speciality hospital in Pune, India**

# EDUCATIONAL INSTITUTE

## Case example: Hybrid air conditioning system

- Centre Point School is located at Nagpur, India
- It has been awarded the IGBC Green School Gold rating
- Air conditioning is provided by water-cooled variable speed screw chillers along with CTI-certified cooling towers
- For providing 50 CFM of fresh air per student in each classroom, on each floor, two 3,000 CFM treated fresh air (TFA) units per floor have been installed
- These TFAs are equipped with dual coils for cooling water (for lowering air temperature) and chilled water coils for dehumidification of air
- When the weather is favorable, cooling water is used (in conjunction with the humidity sensor coupled with control valve) for pre-cooling the air
- Indirect evaporative cooling system coils have been installed in TFA units to substitute chilled water-based air conditioning during dry weather



Source: Centre Point School, Nagpur, India

# EDUCATIONAL INSTITUTE

## Case example: Hybrid air conditioning system (continued)

- At locations with predominantly dry climate, hybrid cooling system can be cost effective, with cooling mode switching between conventional chillers and the evaporative cooling system, depending on the ambient temperature and humidity
- Evaporative cooling is effective only during dry weather
- During operation of the conventional chillers, the TFA unit ensures adequate moisture removal from fresh air, permitting operation of the air conditioning at higher temperature setting
- During cool and dry ambient weather, chillers can be switched off, and chilled water is substituted by 'cold' cooling water from the cooling tower, thus, almost achieving 'free cooling' with minimal cooling tower fan power
- The school has installed 60 kWp of roof top solar PV panels, which generate enough energy for all applications, other than chiller operations

Source: Centre Point School, Nagpur, India



Vapor compression screw chillers with VFD



Treated fresh air system with dual coil

# EDUCATIONAL INSTITUTE

## Case example: Hybrid air conditioning system (continued)

- All classrooms have three-speed FCUs with controls for room temperature and humidity
- Brushless direct current (BLDC) fans are used for room air circulation, for enhancement of thermal comfort, while operating chillers at higher chilled water temperatures



Source: Centre Point School, Nagpur, India

Ceiling fans retained in air-conditioned classrooms

# BUILDING MANAGEMENT AND AUTOMATION

## BMS and BAS for HVAC, lighting and other utilities

Building automation is the automatic centralized intelligent monitoring and control of a building's technical systems and services, such as heating, ventilation and air conditioning (HVAC), lighting and other systems through a building management system (BMS)

Controllers regulate the performance of various facilities within the building environment, which includes:

- Mechanical systems
- Plumbing systems
- HVAC systems
- Lighting
- Electrical system and meters
- Security system
- Surveillance system
- Fire alarm
- Lifts, elevators and escalators



**BAS applications in a commercial building**

Source: Deorukhkar, 2017

# BUILDING MANAGEMENT AND AUTOMATION

## BMS and BAS for HVAC, lighting and other utilities (continued)

- The building automation system (BAS) plays a vital role in automating system operation and optimizing energy consumption of HVAC utility equipment. The BAS can help maintain the desired cooling conditions and modulate the system in relation to the load variations due to occupancy or seasonal changes
- Close monitoring and analysis of operations and energy consumption can improve control, reduce operating cost and even increase the life of equipment. Many green buildings have incorporated BAS to optimize ventilation air, energy and water consumption
- Most building automation networks consist of a primary and secondary bus that connects high-level controllers (generic system or network type, terminal unit type or PLC-based) with lower-level controllers, sensors, input-output devices and user interface (a computer workstation with graphical interface)
- For networking, various type of protocols are used, such as open protocols like ASHRAE's BACnet or LonWorks, or other protocols like SNMP, TCP/IP and Modbus

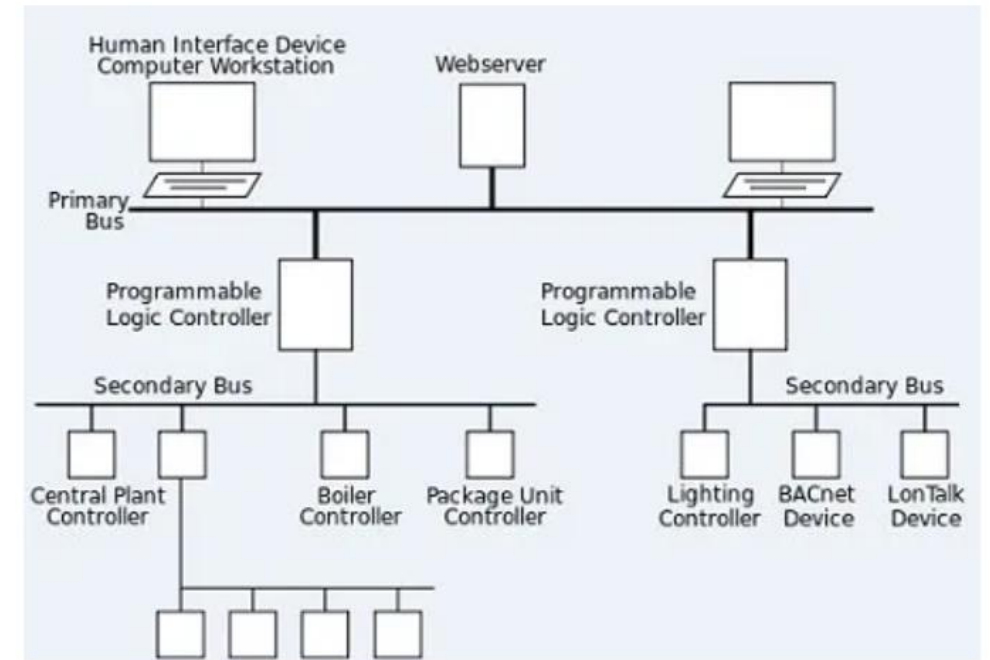

**Typical three-tier system architecture for BAS**

Source: Deorukhkar, 2017

# BUILDING MANAGEMENT AND AUTOMATION

## BMS and BAS for HVAC, lighting and other utilities (continued)

- Field devices and sensors for measuring various HVAC parameters like temperature, humidity, pressure, flow, speed, air quality, lighting intensity, etc. are connected by dedicated optical fiber, Ethernet, ARCNET, RS-232, RS-485 or a low-bandwidth special purpose wireless network
- The user interface involves a PC workstation having graphic interface with various dashboards, graphs or charts. BAS helps facility managers understand and analyze trends, enabling quick troubleshooting and real-time monitoring and control of building operation and performance
- BAS also eases the work of facility managers by providing reports on:
  - Operational data for an equipment or system (with available data points that are integrated with the system)
  - Historical trend (with graphs or charts) for various operational parameters
  - Alarms and/or alerts
  - Incident reports
  - Equipment energy consumption and operating time
- Smart buildings are transitioning from traditional BAS technology to cloud-based information systems, using web-based software

Source: Deorukhkar, 2017

# BUILDING MANAGEMENT AND AUTOMATION

## Case example: Large office complex of online retail company

- The campus of Flipkart, located at Bengaluru, India, comprises three blocks with an approximate total carpet area of 837,279 sq. ft. Space cooling is by a centralized air conditioning system with air-handling units (AHUs)
- One of the issues was **inconsistent cooling with cold and hot spots** across the office spaces. Additionally, in the absence of a building management system (BMS), the facility **lacked AHU scheduling**; all control was manual
- As a retrofit energy-saving project, a BMS with dynamic airflow and chilled water balancing and indoor air quality (IAQ) monitoring systems was incorporated. The system aims to eliminate thermal discomfort, deliver end-to-end automation, and provide customizable dashboards for energy management and IAQ and AHU-level monitoring
- The AI-backed data analysis tool provides a single-pane view of key metrics in real time to analyze critical factors, such as heat maps and occupancy trends for granular-level reporting. The insights and analysis offered in an intuitive graphical user interface empowers the facility team to control buildings with minimal intervention while increasing energy efficiency and maximizing comfort

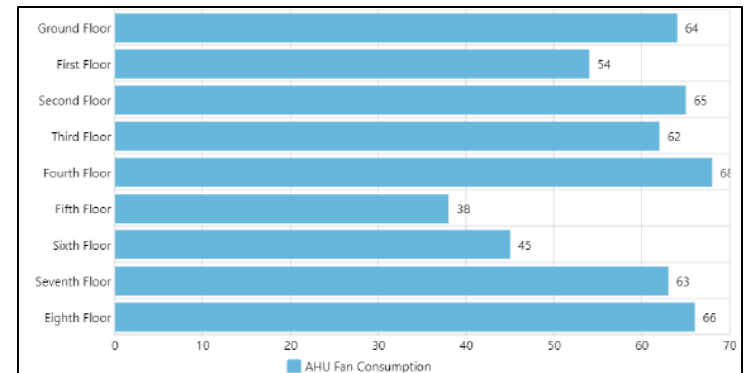
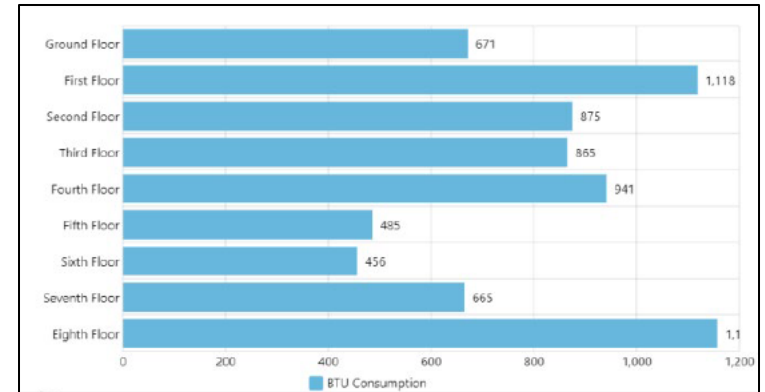

Source: Nawathe, 2023

# BUILDING MANAGEMENT AND AUTOMATION

Case example: Large office complex of online retail company (continued)

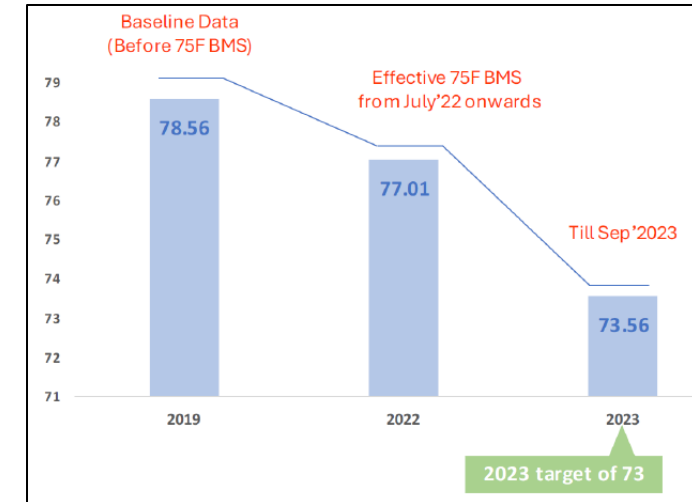
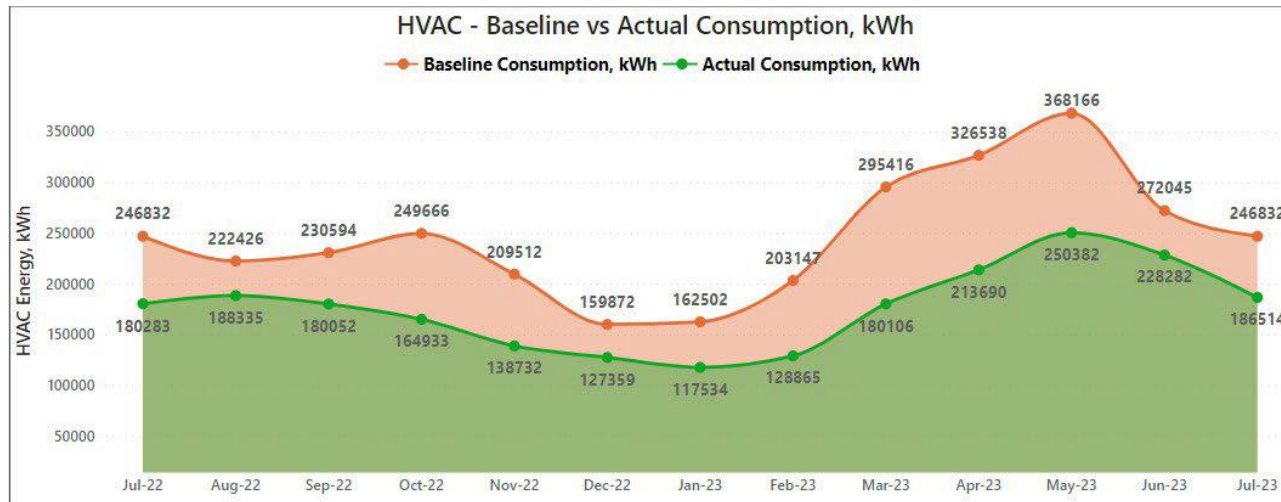

- Within a short span of the project commissioning, the complaints related to hot and cold spots reduced by 60%
- Additionally, the improved air quality helped earn the prestigious UL Certification for IAQ Management
- The energy saving in comparison to the baseline was 27%, with estimated carbon emissions reduction of 711.4 metric tons

Source: Nawathe, 2023

# BUILDING MANAGEMENT AND AUTOMATION

Case example: Small office space of a banking and financial services company

Mode	Manual	Auto	Savings (kWh)	Savings (%)
Total electrical unit (KWh)	183.2	74.2	109	59.4
Total heat load (KWh)	2627	1191	1436	54.6

- A banking and financial services company in Chennai, India, has a HVAC system with an AHU capacity of 9,000 CFM. All controls were manual with variable frequency drives operating at fixed frequency and no modulation of chilled water flow, resulting in uneven cooling across rooms
- Variable air volume sensor boxes were installed to optimize air flows depending on room occupancy. Deployment of an automated air conditioning system ensured that the centralized air conditioning equipment operates at variable speeds, thus optimizing power in relation to prevailing air conditioning loads
- The estimated reduction in cooling load and energy consumption were 54.6% and 59.4%, respectively

Source: ZEDBEE Technologies

# ENERGY MANAGEMENT

## Effective monitoring and control by integrating BMS with EMS

- Many modern buildings still operate with manual controls, based on physical observation of operations or fixed switching at pre-decided clock time. While this strategy may be acceptable for small buildings, large air-conditioned buildings need more sophisticated control
- It is observed that building management system (BMS) in many buildings is used only for monitoring, while controls are manual; automation is necessary for energy optimization. Another common issue is that the BMS is not integrated with the energy management system (EMS), resulting in separate reports for HVAC and energy. The EMS should be an integral part of the BMS to enable creation of a dashboard that can report figures of merit like EPI, kW/TR, cooling kW/sqm, lighting power, etc. in real time
- Simulation studies indicate that BMS based on Internet of Things (IoT) can reduce energy consumption in building HVAC systems by 13%–15% across climatic zones
- Critical review of the trends of important parameters during different weather conditions and building occupancy levels can help identify practical and implementable opportunities for optimizing energy consumption in all areas, especially HVAC through automatic setting resets for temperatures, chilled water flows, HVAC air flows and switching of chillers and auxiliaries. It provides indicators for deterioration in equipment performance due to fouling of heat exchangers, malfunctioning or erratic operation of HVAC and lighting controls, etc.

# EQUIPMENT EFFICIENCIES

## Chillers, pumps and fans: Tools to understand achievable equipment efficiencies

- Building managers and engineers are often not sufficiently aware of the achievable energy efficiency levels for various energy-intensive equipment such as chillers, pumps and fans. Often, decisions are made based on rule of thumb or guidance from equipment vendors, which may not be optimal solutions
- Building engineers should be familiar with simple software tools that are relevant for chillers, pumps and fans to help understand achievable efficiencies for relevant operating parameters of equipment. Some of the free tools available are:
  - CoolPack for chillers (from the Technical University of Denmark)
  - PSAT for pumps (from the Department of Energy, USA)
  - FSAT for fans (from the Department of Energy, USA)
- These tools are discussed in module 3.2(b) on HVAC Systems: Performance Assessment

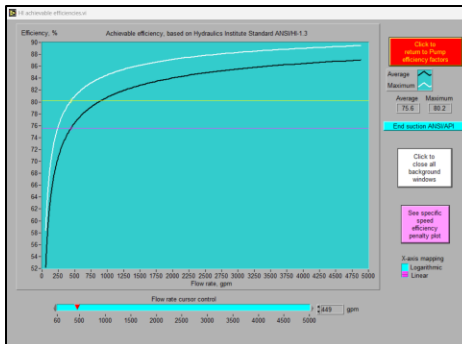
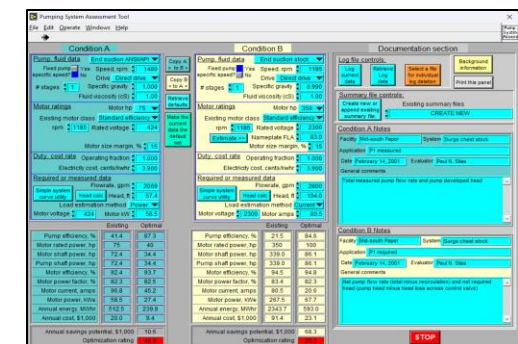
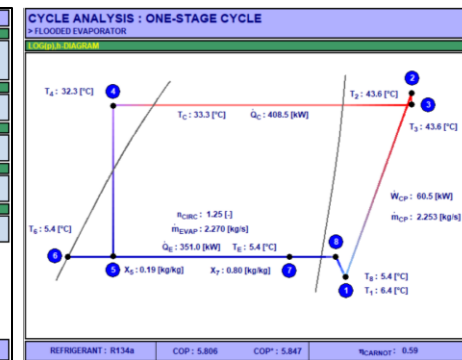
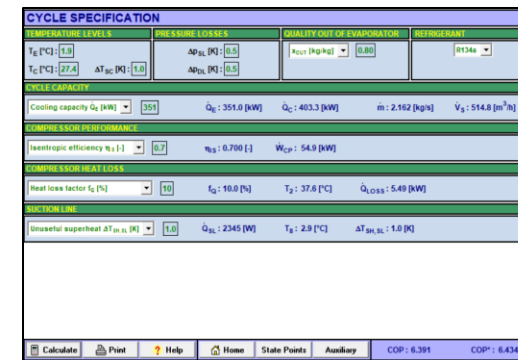

# Thank you!

For more information, visit us at <https://ALCBT.GGGI.ORG>  
or scan the QR code below



## IKI Independent Complaint Mechanism

Any person who believes they may be harmed by an IKI project or who wish to report corruption or the misuse of funds, can lodge a complaint to the IKI Independent Complaint Mechanism at [IKI-complaints@z-u-g.org](mailto:IKI-complaints@z-u-g.org). The IKI complaint mechanism has a panel of independent experts who will investigate the complaint. In the course of the investigation, we will consult with the complainant so as to avoid unnecessary risks for the complainant. More information can be found at <https://www.international-climate-initiative.com/en/about-iki/values-responsibility/independent-complaint-mechanism/>.

 [www.gggi.org](http://www.gggi.org)

 [@gggi\\_hq](https://twitter.com/gggi_hq)

 [@GGGIHQ](https://www.instagram.com/gggi_hq)

 [@GGGIHQ](https://www.facebook.com/gggi_hq)

 [@gggi\\_hq](https://www.linkedin.com/company/gggi_hq)

 [@GGGIMedia](https://www.youtube.com/channel/UCGgI-Media)



Supported by:



on the basis of a decision  
by the German Bundestag

# 2.7 Building Energy Audits

November 2024



Supported by:



on the basis of a decision  
by the German Bundestag

# WHAT WILL YOU LEARN?

Objectives of energy audit

01

Building energy audits: Scope and methodology

02

Instruments required for site measurements

03

Holistic systems approach to energy audit

04

Energy saving opportunities in pumps and water chillers

05

Major energy consuming equipment in buildings

06

Buildings: Areas demanding detailed site study and analyses

07



# ENERGY AUDIT

A diagnostic tool for energy management

- The most commonly-practiced energy performance assessment tool
- Walk-through energy audits
- Detailed energy audits

Energy Auditor



Portable Gadgets



Data Analysis



Energy audit is  
**NOT** a fault-  
finding exercise,  
but an approach  
to identify energy  
saving  
opportunities and  
scope for  
performance  
improvement

# ENERGY AUDIT

## A diagnostic tool for energy management

An *energy audit* can be defined as a systematic exercise for collection and analyses of information on energy consumption and energy costs at macro and micro levels with the following objectives:

- Understand energy consumption and associated costs
- Quantify energy in: per unit of building floor area, per bed in a hospital, per room in a hotel, per employee in a commercial building, per unit of delivery service, per unit of production in an industry, etc.
- Quantify operating energy efficiencies in processes and equipment, supplementing gaps in comparison with best practices
- Identify opportunities to reduce energy consumption and costs through operational changes, retrofits and energy efficient alternatives
- Explore opportunities for substitution of conventional fossil fuel-based energy sources with renewable energy sources
- Explore energy supply side opportunities to reduce energy costs



Image source: <https://comelectrical.com/energy-audit-importance-and-why-you-should-be-prioritizing-it/>

# ENERGY AUDIT (EA)

Types based on objectives, time and resources employed



## Preliminary walk-through EA

A walk-through study usually takes one or two days, depending on the size of the facility, for a quick review of energy consumption and costs, and physical observations of operations without any measurements, to identify areas with potential for energy savings (without detailed measurements or quantification)



## Detailed EA

A detailed study is conducted over a few days or weeks, depending on the size of the facility, involving detailed observations, measurements and analyses for quantification of process and equipment efficiencies, identification of energy and cost saving opportunities, and detailing of recommended measures, with cost-benefit analyses



## Investment grade EA

A very detailed study for preparation of a bankable project report for selected processes and equipment with accurate quantification of energy and cost saving potential, detailing of required project hardware and software, with accurate cost estimates (supported with budgetary quotes from solution providers), and financial analyses

# BUILDINGS

## High-energy-consuming equipment



### Hotels

- Air conditioning equipment
- Hot water generators
- Kitchen equipment
- Laundry equipment
- Lighting



### Hospitals

- Air conditioning equipment
- Hot water generators
- Kitchen equipment
- Laundry equipment
- Lighting



### Assembly spaces

- Air conditioning equipment
- Ventilation fans
- Air circulation fans
- Kitchen equipment
- Lighting



### Offices

- Air conditioning equipment
- Ventilation fans
- Air circulation fans
- Kitchen equipment
- Lighting

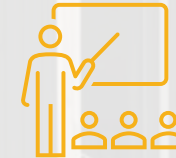

### Educational institutes

- Air conditioning equipment
- Ventilation fans
- Air circulation fans
- Kitchen equipment
- Lighting



### Supermarkets and malls

- Air conditioning equipment
- Ventilation fans
- Air circulation fans
- Kitchen equipment
- Lighting

# BUILDING ENERGY AUDITS

## Typical scope of work

- Energy usage pattern (billing and inventory)
- Transformer (loading and operation)
- DG set (loading and specific fuel consumption)
- Lighting system (inventory, lighting index and illumination survey)
- Air conditioning system (energy efficiency ratio and operation)
- Boiler (efficiency and operation)
- Water pumping system (specific water consumption, pump operation and pump efficiency)
- Hot water generating system (specific energy consumption and efficiency)
- General observation (laundry and kitchen)

## Critical aspects of energy audits

- **Scope of audit**
- **Quality auditor**
- **Quality data**
- **Gadgets and instrument**
- **Participative**

# BUILDING ENERGY AUDITS

## Important equipment

- Electric motors
- Central water chillers
- Unitary air conditioners
- Precision air conditioners
- Steam and hot water generators
- Heat pumps
- Air handling units
- Cooling towers
- Pumps
- Fans and blowers
- Kitchen and pantry equipment
- Laundry equipment
- Office equipment
- Lighting

# BUILDING ENERGY AUDITS

## Objectives

- Correlate monthly energy consumption and cost with service delivered, floor area, occupancy, weather parameters, etc. for establishing Energy Performance Indexes (EPIs) with appropriate metrics and benchmarking
- Understand energy sources and accounting of energy consumption in significant end uses. Typical energy guzzlers are building air conditioning, hot water generation, kitchen equipment, laundry equipment and lighting
- Establish energy efficiencies or alternative figures of merit for energy-intensive equipment and systems
- Identify gaps and opportunities for energy optimization by improving energy efficiencies, reduction of losses and other innovative measures
- In buildings with both heating and cooling applications, explore possibilities for heat integration, including waste heat and cold recovery, to reduce the demand for cooling and heating
- Explore scope for using renewable energy for electricity generation and heating and cooling applications
- Suggest improvements in the energy monitoring and control system



# BUILDING ENERGY AUDITS

## Approach and methodology

- Walk through building and utility areas to understand energy sources, energy-intensive end-use equipment and systems, building utilization, occupancy patterns, etc.
- Collect monthly energy consumption data (overall and area-wise), energy costs, inventory of electrical and fuel-fired equipment, and weather data
- Critically review information from building management system or energy management system (if available)
- Holistically study energy-intensive equipment and systems. In most buildings, high energy consumption can be expected in air conditioning, water heating, water pumping and lighting
- Perform spot measurements and prolonged data logging (if required) of operating parameters of relevant equipment and systems
- Confirm segregation and utilization of air-conditioned and naturally-ventilated building spaces. This includes quantification of building cooling and heating load (sensible and latent heat loads) and contribution of heat ingress from building envelope (roof, walls, glass and air ingress)



# BUILDING ENERGY AUDITS

## Approach and methodology (continued)

- Quantify equipment and system energy efficiencies or appropriate figures of merit
- Quantify energy consumption in lighting during daytime and nighttime, with the objective of reducing daytime electric lighting
- Understand the energy consumption of energy-intensive appliances, such as unitary air conditioners, hot water generators, laundry equipment, kitchen equipment, etc.
- Identify unused roof area and other open areas for possible installation of solar photovoltaic systems or solar heating systems
- Critically analyze data to identify energy saving opportunities from operational changes, retrofits or replacements with more efficient equipment
- Firm up energy saving recommendations, along with quantification of energy saving potential, estimates of investment required, projected returns on investment, and contacts of relevant vendors and solution providers
- Draft the energy audit report, followed by presentation and discussion with clients
- Finalize the energy audit report, incorporating clients' concerns and modifications in recommendations



# ENERGY AUDIT

## Instruments used in site studies



Power analyzer with clamp-on current transformers

*Image source: Krykard*



Ultrasonic flow meters

*Image source: Acorn Controls*



Anemometer

*Image source: UNI-T*



Flue gas analyzer

*Image source: Testo*



Thermometers

*Image source: Artech*

# ENERGY AUDIT

## Instruments used in site studies (continued)



Sling psychrometer  
*Image source: BHI*



Manometer with pitot tube  
*Image source: Sunflow Technologies*



Pressure gauges  
*Image source: Nishka Instruments*



Lux meter  
*Image source: Lutron*



Thermal imager  
*Image source: Testo*

# ENERGY AUDIT

## HVAC system: A holistic approach is recommended

- To achieve significant energy savings, it is recommended that each energy-intensive equipment is not studied in isolation, but as part of the larger system in which it operates
- For example, a pump operates in a system involving piping, valves, heat exchangers, etc. Even when the pump efficiency is good, the overall pumping system efficiency may be poor due to excess flow or avoidable pressure losses in the system
- Similarly, a water chiller may be efficient, but the heat of load on the chiller may comprise of some spurious, avoidable heat loads
- In the case of lighting, the priority should be to maximize the use of natural lighting before focusing on energy efficient lamps, gears and controls

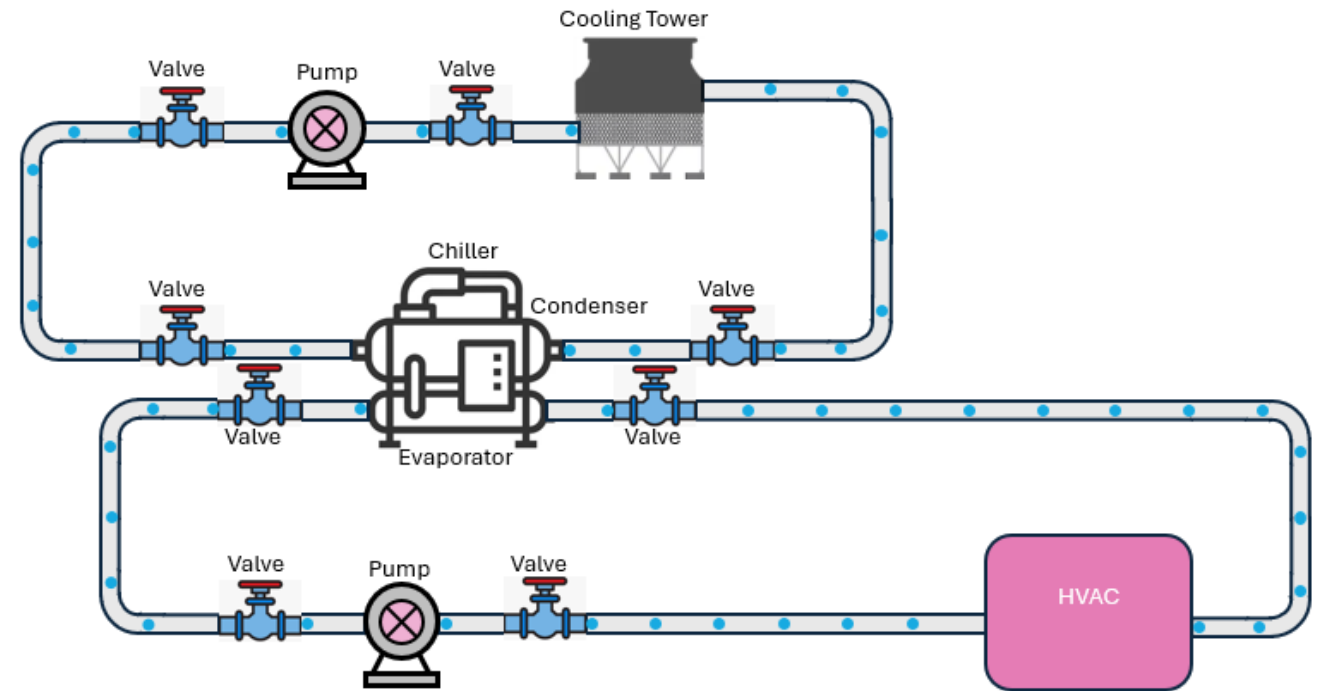

Typical chilled water system

Image source: Devki Energy Consultancy Pvt. Ltd., India

# HVAC PUMPING SYSTEM

## Energy losses in HVAC system circulation pumps

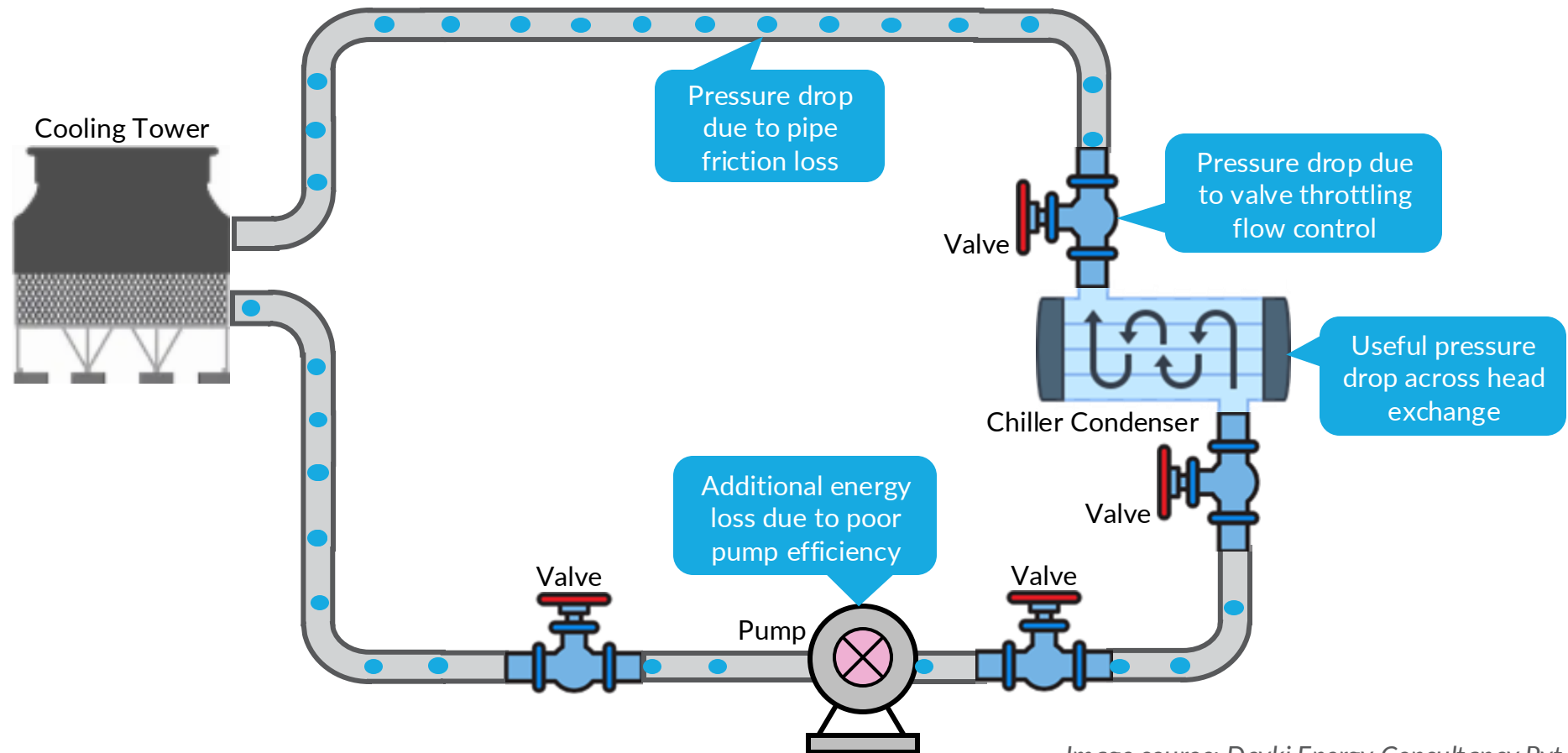
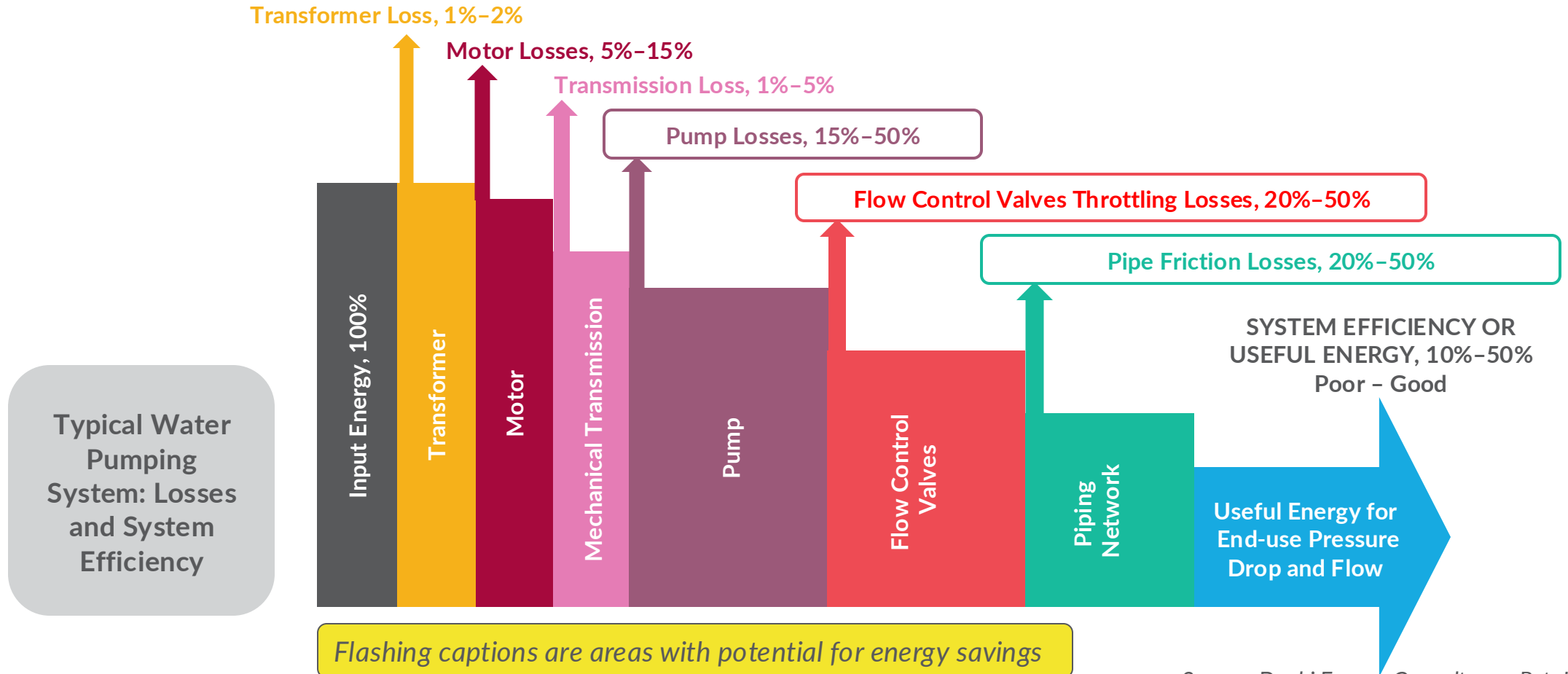

Image source: Devki Energy Consultancy Pvt. Ltd., India

# HVAC PUMPING SYSTEM

A holistic understanding of energy losses and system efficiency



Source: Devki Energy Consultancy Pvt. Ltd., India

# HVAC PUMPING SYSTEM

## Typical energy saving opportunities

- Optimization of chilled and cooling water circulation rates and operating head
- Elimination of valve throttling losses by incorporating variable speed drives for flow control
- Optimization of the number of parallel pumps in a system for achieving good operating efficiency and reliability
- Ensuring optimal sizing of pipes to reduce pressure losses due to pipe friction
- Selection of appropriately-sized high efficiency pumps
- Regular pump maintenance, monitoring and control to ensure optimal operation

*Pumping system efficiencies (including all system losses) can be improved from usually prevailing levels of 10%-20% to 40%-50% by minimizing or eliminating valve throttling losses and ensuring selection of pumps with optimal head and flow, with the highest available pump efficiency*

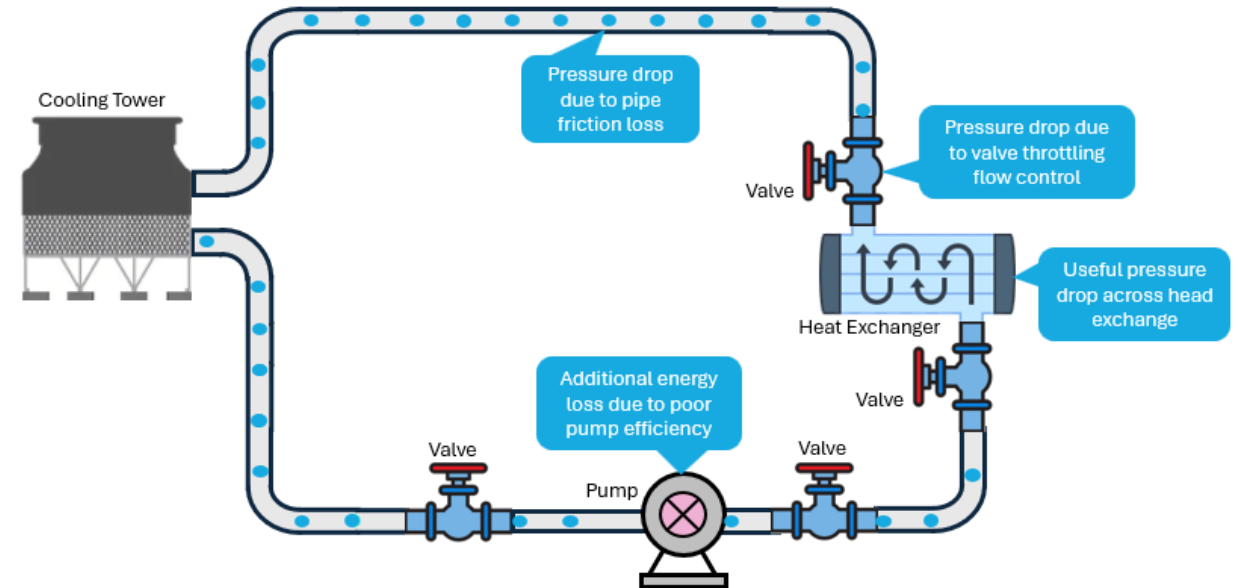

Image source: Devki Energy Consultancy Pvt. Ltd., India

# HVAC WATER CHILLERS

## Energy losses in HVAC water chilling systems

### Likely reasons for poor chiller performance

1. Poor chilled water temperature control
2. Prolonged chiller operation at partial load
3. Inadequate chilled water and/or cooling water flows
4. Fouling of evaporator and/or condenser
5. Poor cooling tower or air-cooled condenser performance
6. Inadequate heat transfer area in evaporator or condenser

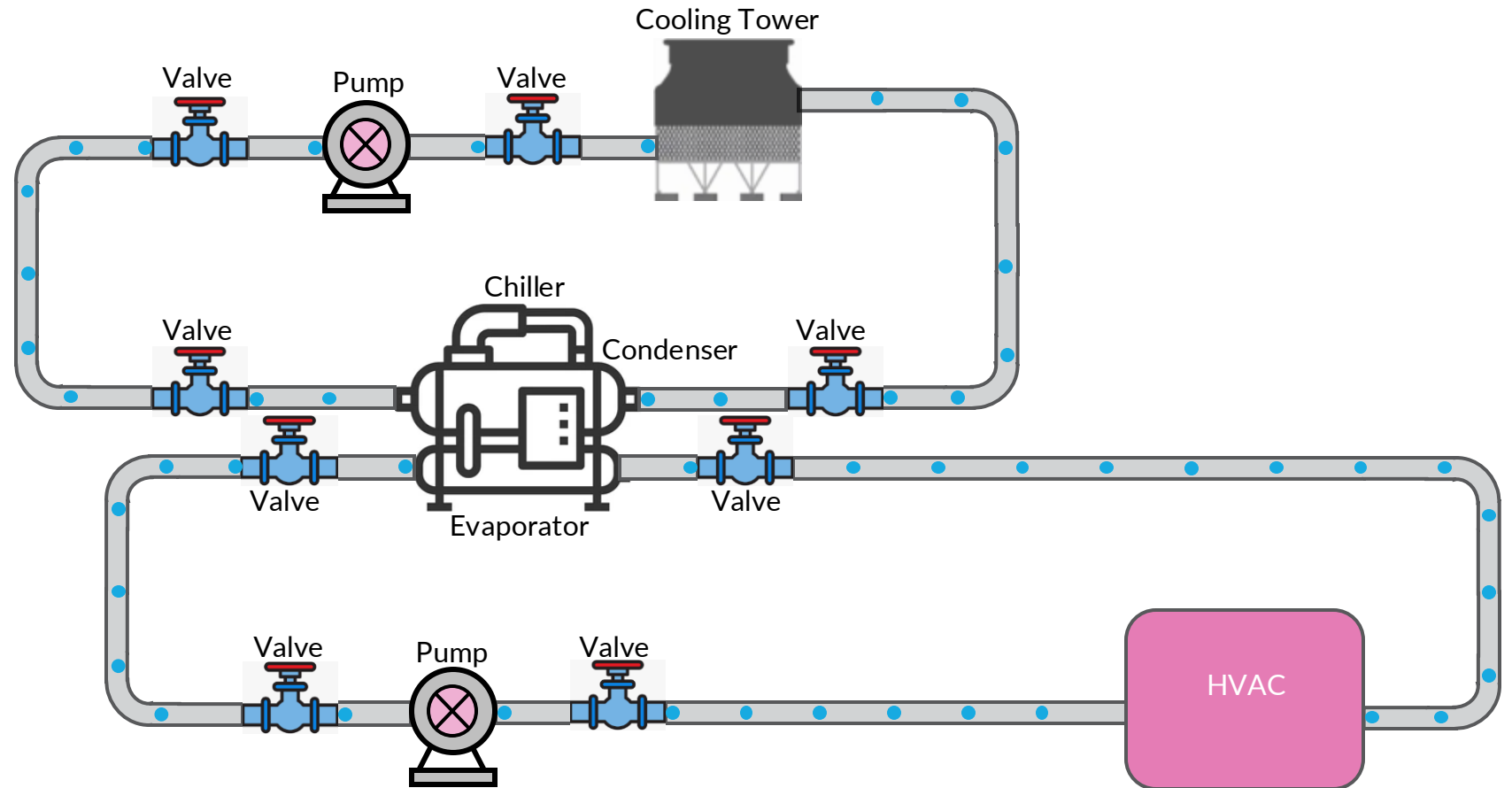

Source: Devki Energy Consultancy Pvt. Ltd., India

# HVAC SYSTEMS

Holistic system approach to identify efficiency gaps and energy losses

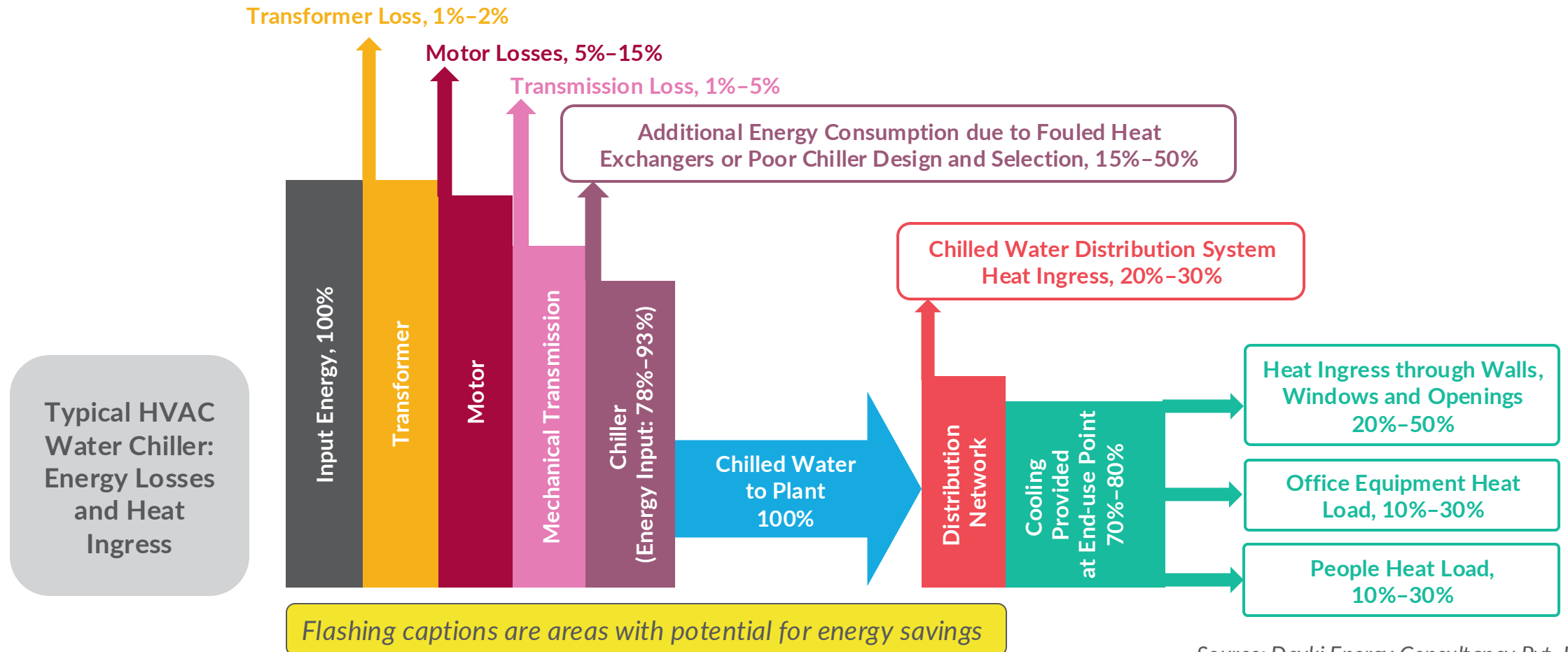

Source: Devki Energy Consultancy Pvt. Ltd., India

# HVAC SYSTEMS

## Energy saving opportunities

- Maintenance of optimal temperature and humidity levels with effective feedback controls and optimal AHU fan flows using variable frequency drives
- Minimization of demand for energy-intensive room air conditioning by using natural ventilation to the extent possible and other innovative, less energy-intensive solutions, such as evaporative cooling
- In warm and humid climatic zones, use of *treated fresh air (TFA) units* to reduce humidity of fresh air enables operation of air conditioning system at higher temperatures without causing discomfort
- Reduction of heat ingress into buildings by optimizing glass-to-wall ratio, ensuring proper thermal insulation and integrating ventilation air heat recovery
- Use of *precision air conditioners with energy recovery technologies for low relative humidity air conditioning*



Image source: <https://www.rsi.edu/blog/hvacr/introduction-to-energy-efficient-hvac-what-hvac-students-need-to-know/>

# HVAC SYSTEMS

## Energy saving opportunities (continued)

- In chillers, ensure adequate evaporator and condenser heat transfer areas with optimal fluid flows to improve the coefficient of performance (COP)
- Maintenance of cleanliness of heat transfer surfaces with special coatings and automatic cleaning systems
- Use of variable speed drives on chiller compressors that operate at variable load to achieve significantly higher COP (compared to design values) at partial loads
- Use of appropriately-sized higher efficiency pumps
- Use of high efficiency fans with BLDC motors in AHUs



Image source: <https://www.rsi.edu/blog/hvacr/introduction-to-energy-efficient-hvac-what-hvac-students-need-to-know/>

# ENERGY OPTIMIZATION

## HVAC systems: Typical issues

- Excessive heat load through building envelope, especially due to high glass-to-wall ratio
- External air ingress and poor control over ventilation
- Operation at lower temperatures to overcome end-use temperature issues due to improper air distribution
- Excessive air recirculation flows in rooms
- Absence of control over chillers and air conditioners during low room occupancy hours
- Low operating COP of chillers due to operation at multiple loads
- Low operating COP due to issues in condenser cooling, such as low coolant flow, fouling of heat transfer surfaces, poor performance of cooling towers, etc.
- Low operating COP of unitary air conditioners due to poor maintenance or selection of less efficient air conditioners
- Inadequacy of refrigerant charge in the system
- Poor efficiencies of pumps due to inappropriate selection
- Significant valve throttling losses in pumps
- Poor efficiencies of AHU fans
- High *time of day (TOD)* charges due to absence of thermal storage system

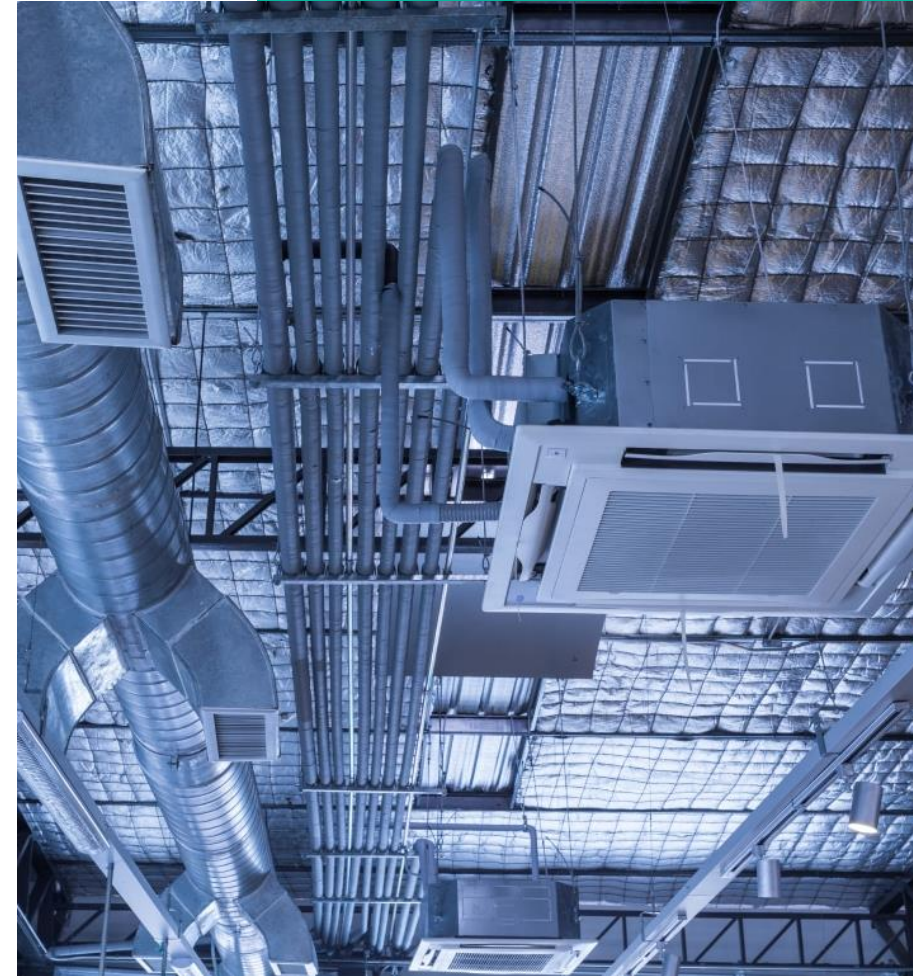

Image source: <https://galooli.com/glossary/what-is-hvac/>

# ENERGY SAVING OPPORTUNITIES

## Lighting: Typical issues

- Use of electric lighting during daytime
- Possibility of retrofitting of light shelves
- Possibility of retrofitting lamp dimming devices
- Possibility of use of low wattage lamps with improved luminaires
- Optimization of building façade lighting
- Control and optimization of outdoor lighting



Image source: Wipro Lighting

# ENERGY AUDIT REPORT

## Contents

- Summary of major recommendations
- Introduction to the facility
- Description of building and activities within
- Analyses of energy consumption and correlation using appropriate metrics
- Presentation of collected data, analyses and energy saving recommendations, with quantified savings
- Cost-benefit analyses for all recommendations
- Benchmarking of energy consumption
- Suggestions for improved energy monitoring and control
- A comprehensive list of good operating practices
- Annexures: Detailed compilation of measurements, references, etc.



Image source: <https://www.minzinc.com/products-20-6.html>

# Thank you!

For more information, visit us at <https://ALCBT.GGGI.ORG>  
or scan the QR code below



## IKI Independent Complaint Mechanism

Any person who believes they may be harmed by an IKI project or who wish to report corruption or the misuse of funds, can lodge a complaint to the IKI Independent Complaint Mechanism at [IKI-complaints@z-u-g.org](mailto:IKI-complaints@z-u-g.org). The IKI complaint mechanism has a panel of independent experts who will investigate the complaint. In the course of the investigation, we will consult with the complainant so as to avoid unnecessary risks for the complainant. More information can be found at <https://www.international-climate-initiative.com/en/about-iki/values-responsibility/independent-complaint-mechanism/>.

 [www.gggi.org](http://www.gggi.org)

 [@gggi\\_hq](https://twitter.com/gggi_hq)

 [@GGGIHQ](https://www.instagram.com/GGGIHQ)

 [@GGGIHQ](https://www.facebook.com/GGGIHQ)

 [@gggi\\_hq](https://www.linkedin.com/company/gggi-hq)

 [@GGGIMedia](https://www.youtube.com/GGGIMedia)



Supported by:



on the basis of a decision  
by the German Bundestag

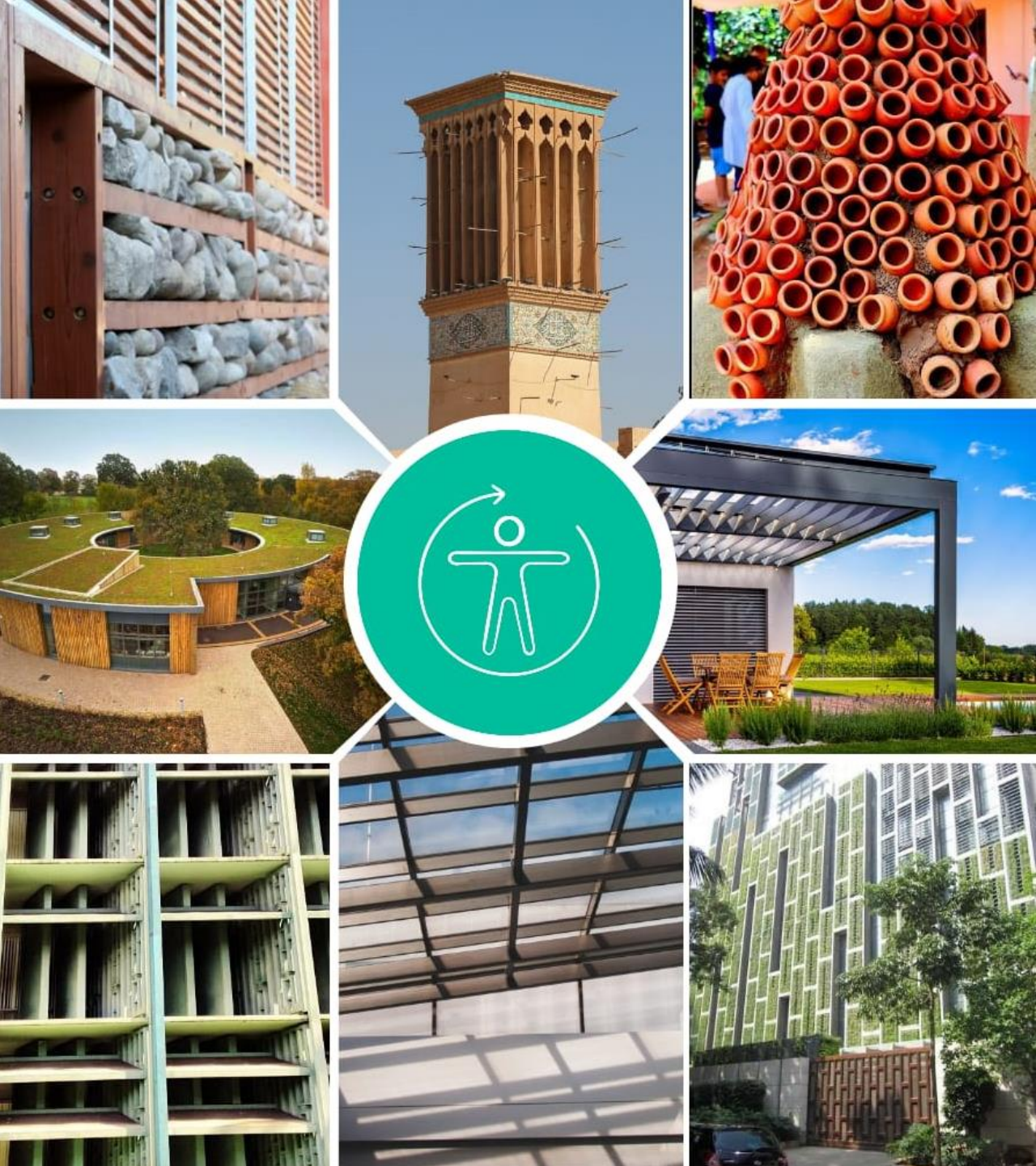

## 2.8 Tools for Planning and Design of Low Carbon Buildings

November 2024

# WHAT WILL YOU LEARN?

Integrated  
Design  
Process

01

Building  
Energy  
Simulation

02

Daylight  
Simulation

03

Natural  
Ventilation  
Simulation

04

Case  
Examples

05



# Integrated Design Process

A Design Tool

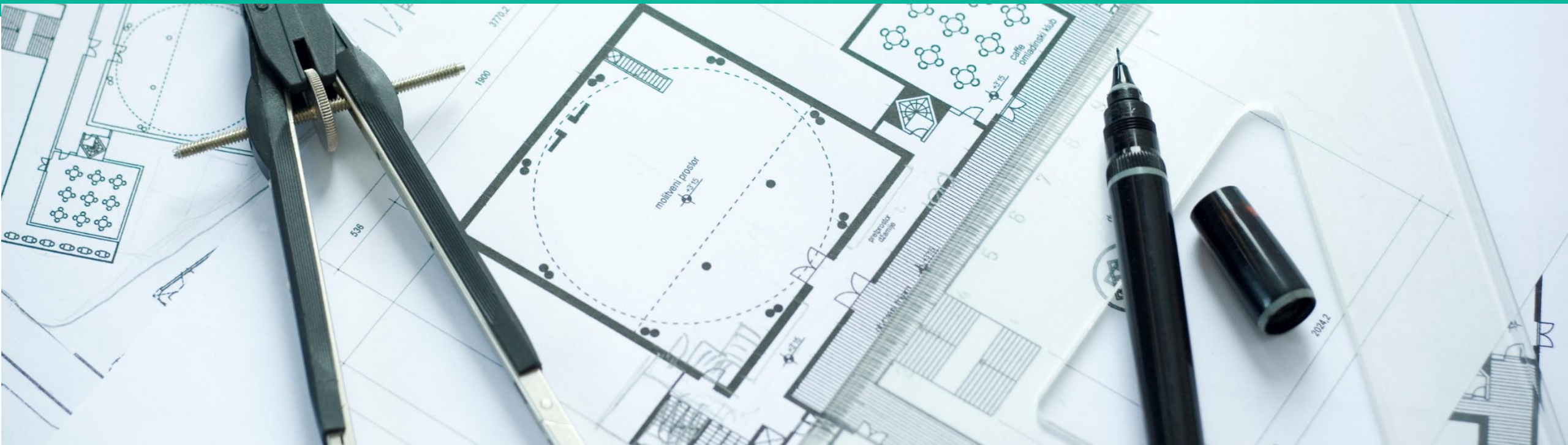

# CONVENTIONAL DESIGN PROCESS

Lack of integrated view of the project

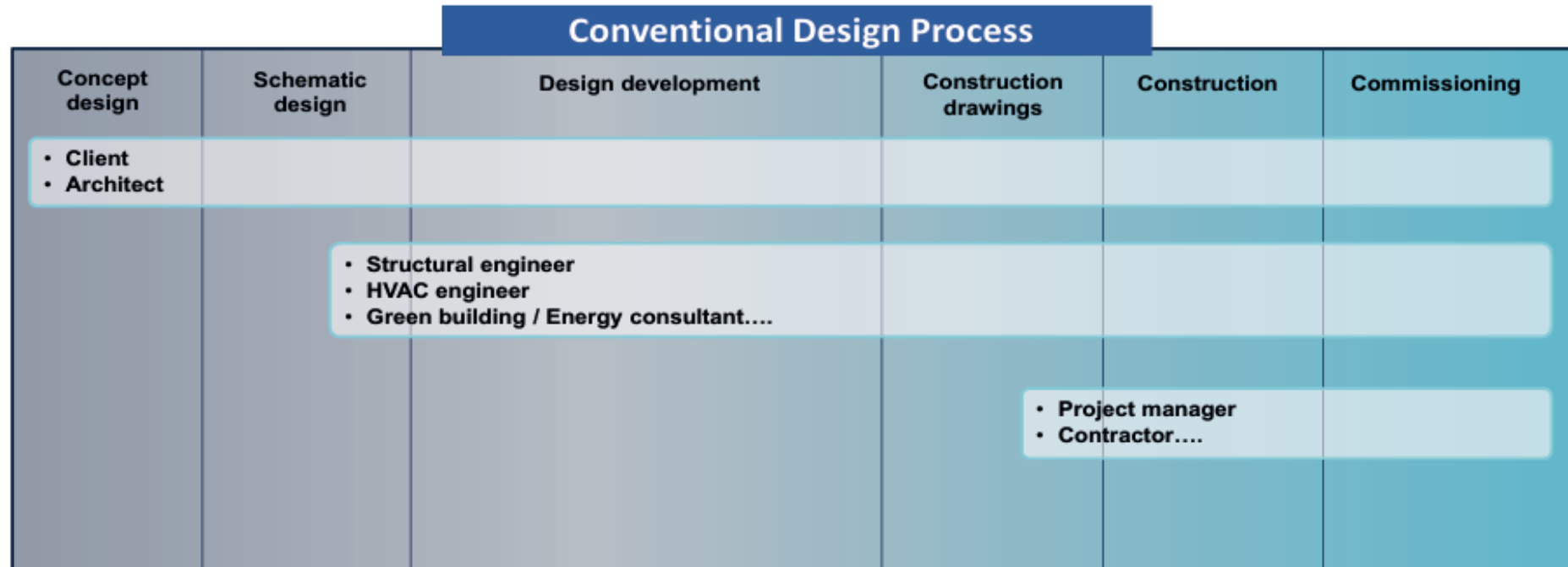

A **sequential process** where different specialist design consultants and stakeholders are brought in separately after much of the architectural design has been fixed to give their respective technical inputs

Source: BEEP Design Charrette Manual

# INTEGRATED DESIGN PROCESS

## When to have an integrated design charrette?

- Integrated design means that most of the stakeholders, if not all, start **working on the project together** right from the beginning, based on the design brief
- The best and most effective time to have the first charrette is at the **conceptual stage of the design**, with all or most of the stakeholders (the decision-makers, the people financing the project, the ones designing and constructing, and the ones operating and using it) on board

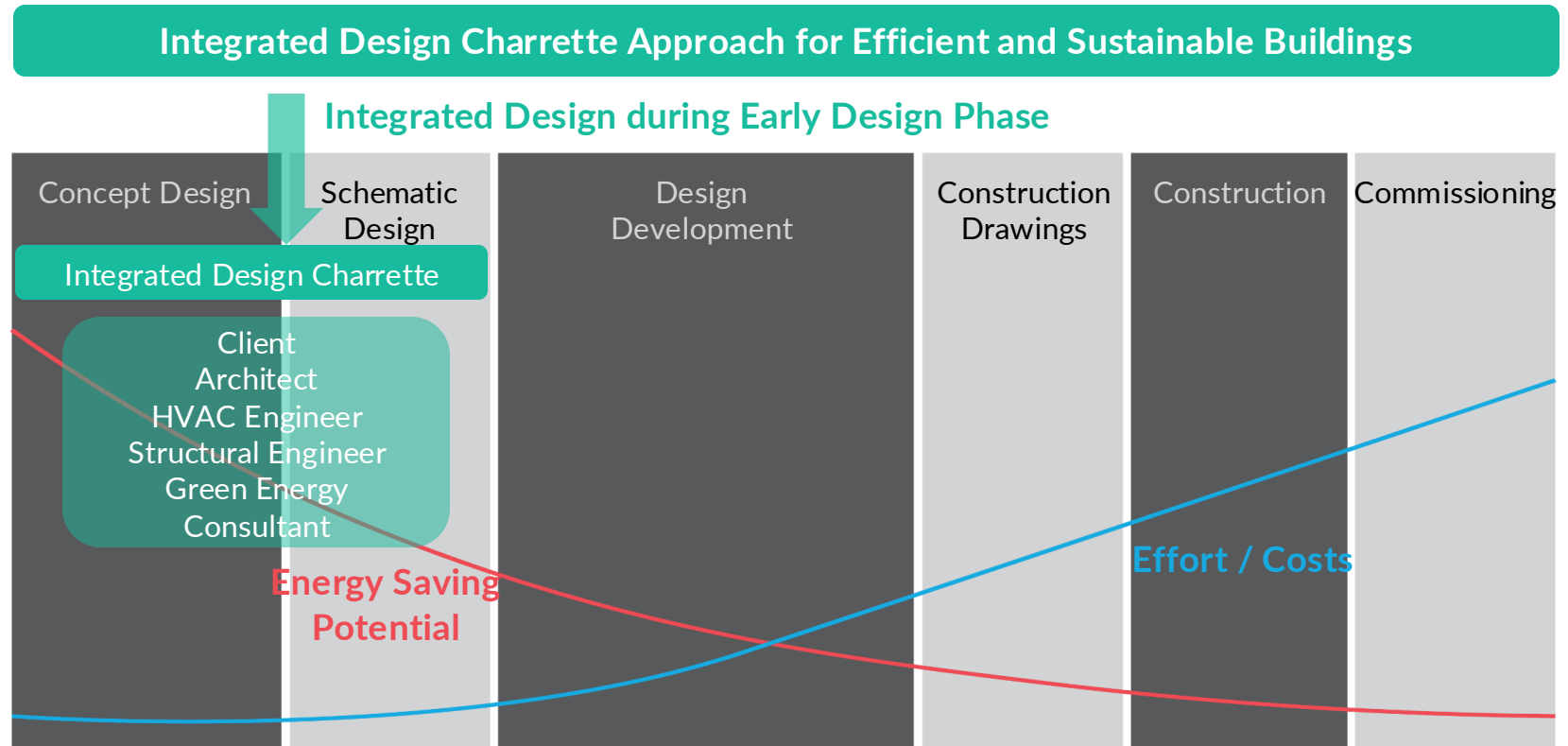

Source: BEEP Design Charrette Manual

# WHAT DO YOU INTEGRATE?

Step-by-step strategies to reduce operational energy consumption

- An **Integrated design process** aims to get a **climate responsive design first**, and then complements it with efficient and sustainable mechanical technologies
- A **charrette** is a tool to implement an integrated design process, wherein all stakeholders work together in an intense manner over a short time period

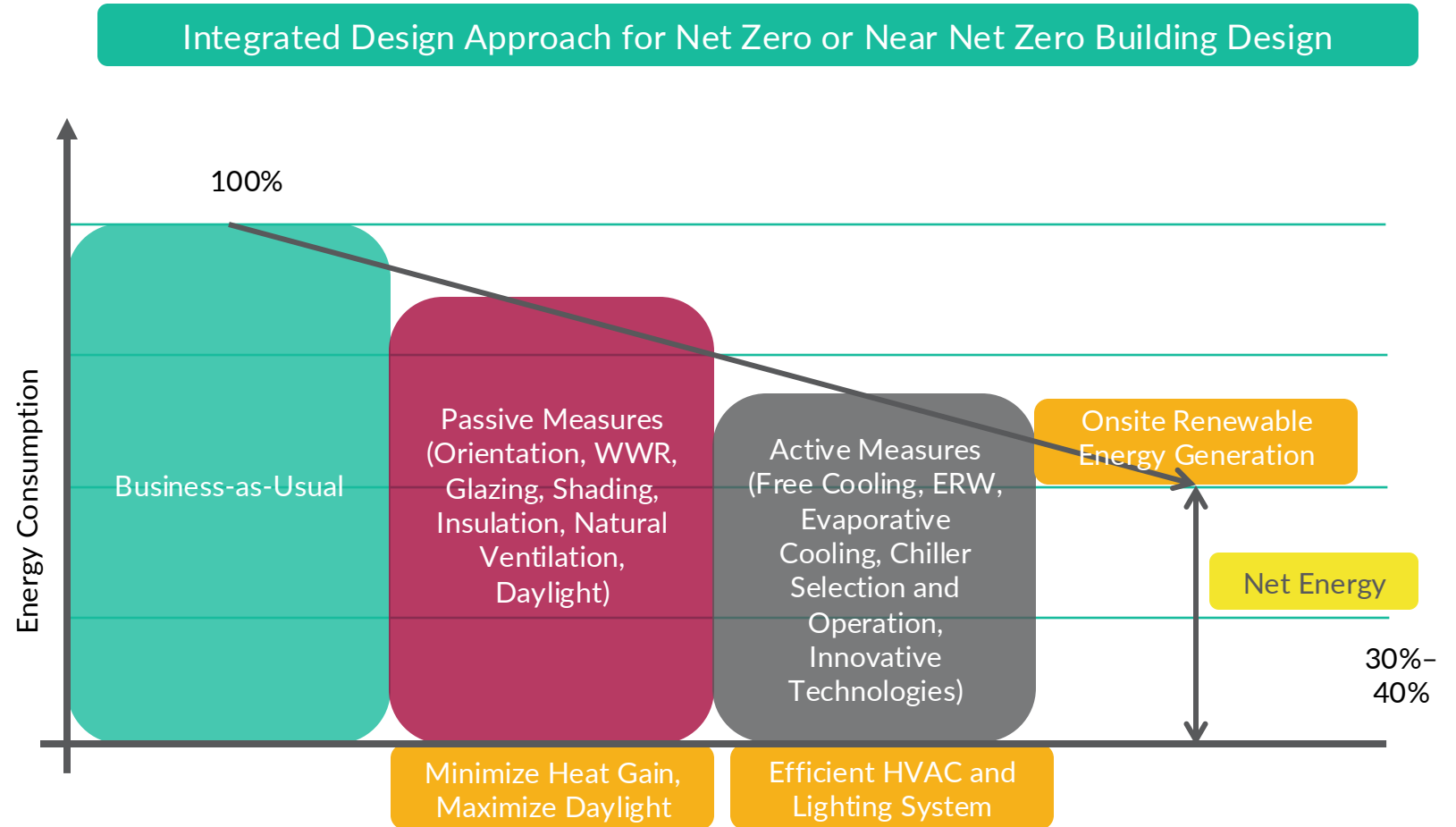

Source: BEEP Design Charrette Manual

# WHAT DO YOU INTEGRATE?

Integrating materials with low embodied carbon

Concept design	Schematic design	Design development	Construction	Commissioning
<p><b>SET GOALS</b></p> <ul style="list-style-type: none"> <li>• Comfort &amp; EPI</li> <li>• CO<sub>2</sub> intensity</li> </ul>	<p><b>SHAPE &amp; MASSING OPTIONS</b></p>	<p><b>REDUCTIONS IN CEMENT &amp; STEEL</b></p>	<p><b>CONFIRM OPTIMISATIONS</b></p>	
<p><b>DO YOU NEED TO BUILD NEW?</b></p>	<p><b>STRUCTURAL SYSTEM</b></p>	<p><b>ENVELOPE HOT-SPOTS</b></p>	<p><b>REDUCE MATERIAL WASTE / RECYCLE</b></p>	
<p><b>CAN YOU REUSE / RECYCLE MATERIALS OF EXISTING BUILDING?</b></p>	<p><b>ENVELOPE DESIGN</b></p>	<p><b>INTERNAL LAYOUTS; AVOID ELEMENTS WITH LIMITED VALUE</b></p>		
	<p><b>TYPE OF HVAC SYSTEM etc.</b></p>	<p><b>DEVELOP SPECIFICATIONS &amp; INCLUDE IN BID DOCS</b></p> <ul style="list-style-type: none"> <li>• Material thermal properties</li> <li>• Material / Product EPDs or CO<sub>2</sub> intensity</li> <li>• Equipment efficiencies</li> </ul>		
	<p><b>DESIGN FOR DISMANTLING</b></p>			

Operational & Embodied Carbon

Operational Carbon

Embodied Carbon

Source: BEEP Design Charrette Manual

# INTEGRATED DESIGN CHARRETTE

## Setting goals

### Commercial buildings

- Mostly air-conditioned
- Narrow band of expected comfort
- Air conditioning used for longer duration and may be used throughout the year
- Heat loads in the building may have equal or more contribution from internal loads, i.e., from occupants and equipment



### **Charrette goals**

- Reduction in Energy Performance Index (EPI), either in comparison to the base design as per an existing benchmark EPI, specifically cooling EPI
- Additional parameters evaluated for specific problem identification or problem solving:
  - Heat gains from different building components
  - HVAC system size and efficiency
  - Daylight
  - Free cooling potential

### Residential buildings

- May or may not be air-conditioned
- Broader band of expected comfort
- Air conditioning intermittently during the day and used mainly in summer
- Heat loads in the building dominated by external loads i.e., those from the building envelope



### **Charrette goals**

- Reduction in peak summer internal operative temperature, in comparison to the base design
- Minimizing the discomfort degree hours (DDH), mainly in summer, when assessed as per the IMAC (NV) or IMAC (MM) comfort bands
- Additional parameters evaluated for specific problem identification or problem solving:
  - Heat gains from different building components or building envelope as a whole (RETV)
  - Cooling energy if the assessed space is air conditioned
  - Natural ventilation potential

Source: BEEP Design Charrette Manual

# STRATEGIES AND ANALYSIS TOOLS

To reduce operational energy

Weather data  
(.epw files, etc.)

Climate analysis tool  
(ClimateConsultant, Rhino + grasshopper, etc.)

Sun-path and solar radiation analysis  
(Rhino + grasshopper, etc.)

Thermal comfort and energy simulation tool  
(EnergyPlus, DesignBuilder, etc.)

Daylight simulation tool  
(Radiance, DesignBuilder, etc.)

Natural ventilation potential

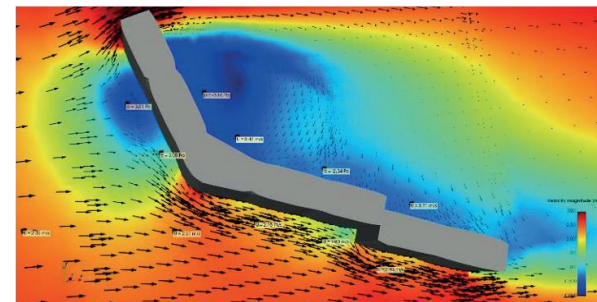
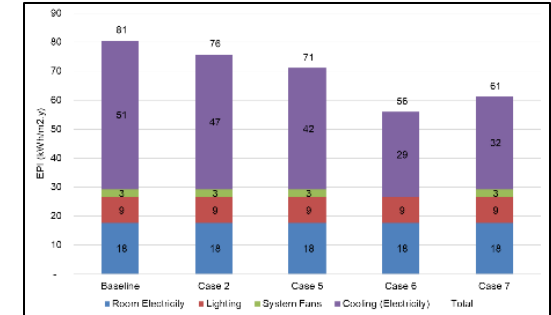
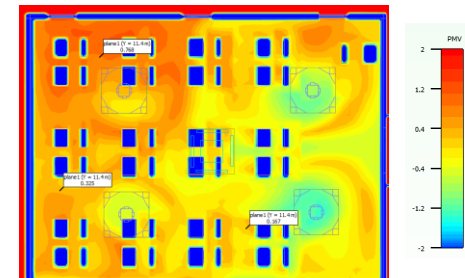
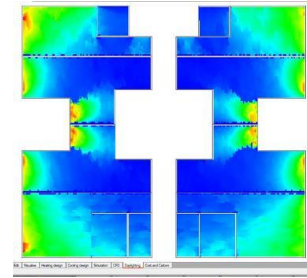
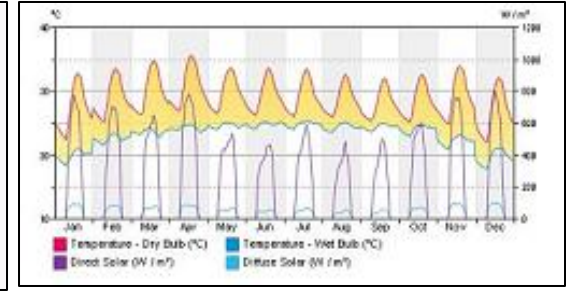
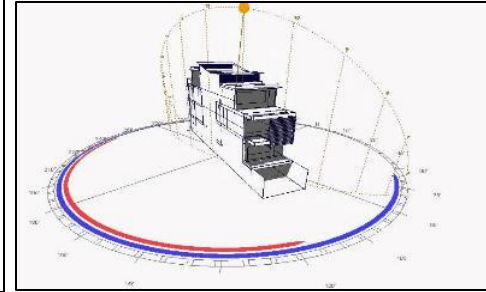
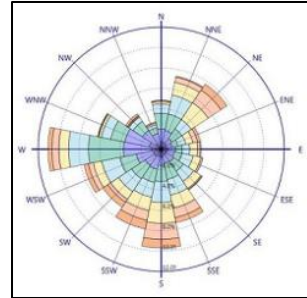

# DESIGNERS' ROLE

## Elements to be addressed

An architect's primary function is to  
**'create an environment'**

This environment has both  
**psychological and physiological**  
effects on the occupants

The environment impacts

- **Human productivity**
- **Visual comfort**
- **Thermal comfort**

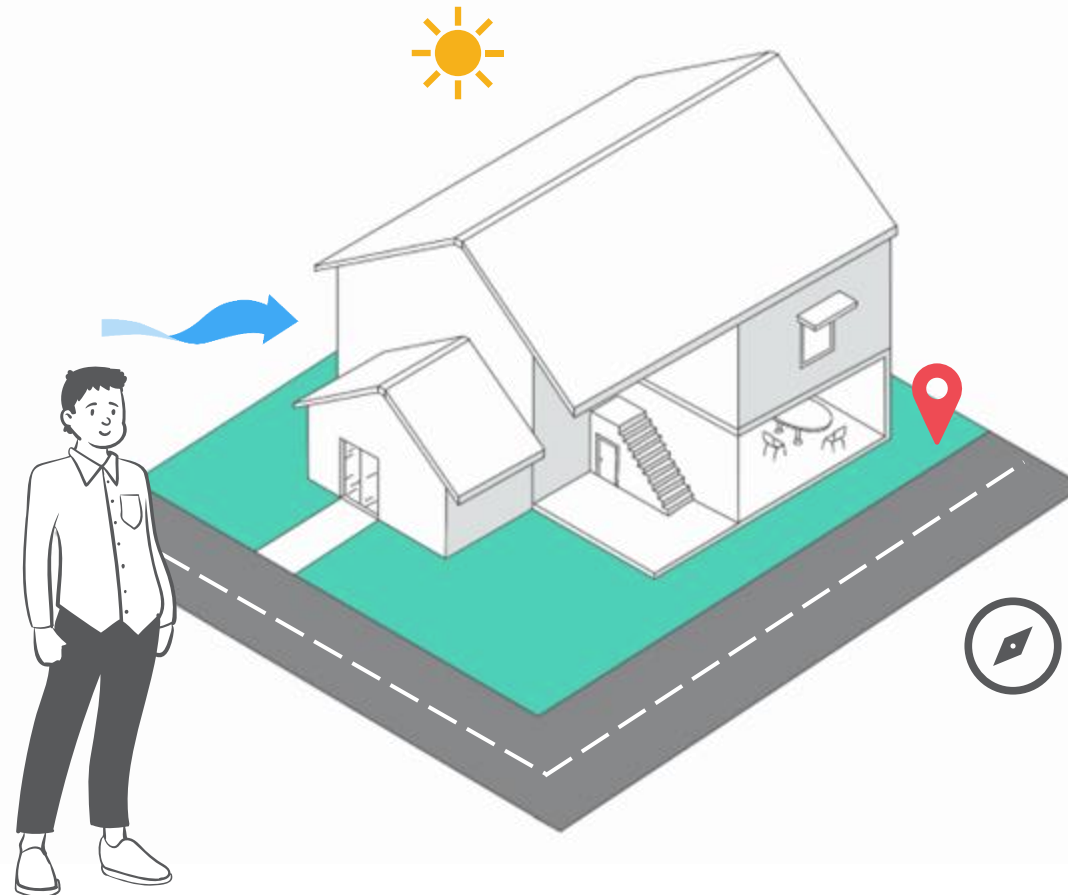

Site location

Building orientation  
and geometry

Building envelope

Arrangement of  
space

Local climatic  
characteristics

# Building Energy Simulation

Tool for Whole Building Analysis



Image source: <https://www.azobuild.com/article.aspx?ArticleID=8520>

# BUILDING PERFORMANCE SIMULATION

## Understanding fundamentals

**Simulation:** An **approximate imitation** of the operation of a **process or system**; that represents its operation over time

**Computer simulation:** To **model a real-life or hypothetical situation on a computer** so that it can be **virtually** studied to see how the system works with **change in variables**

**Building performance simulation:** The replication of aspects of building performance using a **computer-based mathematical model** created on the basis of **fundamental physical principles** and **sound engineering practice**. The objective of building performance simulation is the **quantification** of aspects of **building performance** that are relevant to the design, construction, operation and control of buildings

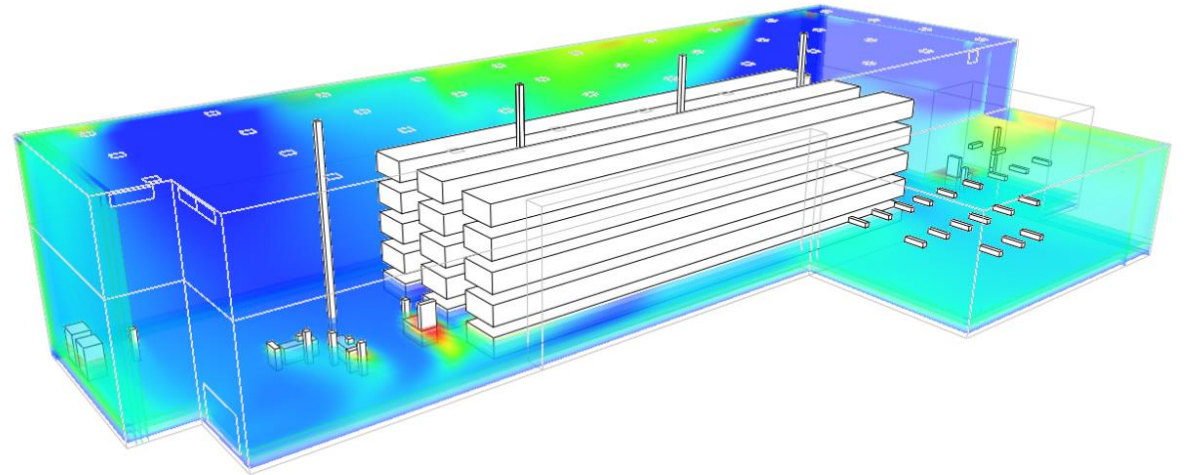

Sources: <https://en.wikipedia.org/wiki/Simulation>; [https://en.wikipedia.org/wiki/Building\\_performance\\_simulation](https://en.wikipedia.org/wiki/Building_performance_simulation)  
Image source: <https://baumann-us.com/services/building-performance-simulations/>

# BUILDING PERFORMANCE SIMULATION

## Why is it needed?

To arrive at the **best possible** building design solution by **quantitative evaluation** of various design options

To estimate **energy performance**:

Energy consumption by different end uses such as lighting, air conditioning, etc.

To understand the **impact of climate** on energy performance

To **quantify** energy saving and improvement in thermal comfort through different energy conservation measures (ECMs); helping in **decision-making**



To estimate the **thermal comfort** inside the building

To identify **key areas** that has more **potential**

To **save time** (manual calculations are complex and require more time)

# BUILDING SIMULATION SOFTWARE

## Selecting the right package

### List of software packages

- **Energy Plus** (graphical user interface e.g., Design Builder, Sefaira, Simergy)
- DOE 2.2 based (e.g., eQUEST, VisualDOE)
- ApacheSim based IES
- TRNSYS
- IDA Indoor Climate and Energy (IDA ICE)
- ESP-r
- TRACE700
- HAP

### Selecting a software

- Must be a validated or approved software
- Modeling capability
  - HVAC
  - Advanced components
  - Natural ventilation
  - Adiabatic, evaporative cooling
  - Parametric analysis
  - Possibility to add specific capability?
    - Source code well described? Accessible?
    - Co-simulation capabilities?
- Technical support, user forum, tutorials, etc.

Source: <https://www.ibpsa.us/best-directory-list/>

[https://climate.onebuilding.org/papers/2005\\_07\\_Crawley\\_Hand\\_Kummert\\_Griffith\\_contrasting\\_the\\_capabilities\\_of\\_building\\_energy\\_performance\\_simulation\\_programs\\_v1.0.pdf](https://climate.onebuilding.org/papers/2005_07_Crawley_Hand_Kummert_Griffith_contrasting_the_capabilities_of_building_energy_performance_simulation_programs_v1.0.pdf)

# BUILDING SIMULATION SOFTWARE

## Proceeding with the simulation

### Early design stage

- Simulate a small portion of the building in detail
  - E.g., typical floor of an office building, typical spaces of an apartment building
- Simulate specific parts or features of the building
  - E.g., consider a specific model for down-draft evaporative cooling, CFD
- Simulate the whole building in less detail
  - Look at global orientations, façades, solar gains

### What to check?

- Feasibility of different options
- Extreme conditions
- Focus on extreme conditions to check feasibility of different option
- Quick check of energy performance for comparison

### Later stages

- Provide a more detailed focus on energy performance and more complete modeling for the zones

# BUILDING SIMULATION SOFTWARE

## Inputs and outputs

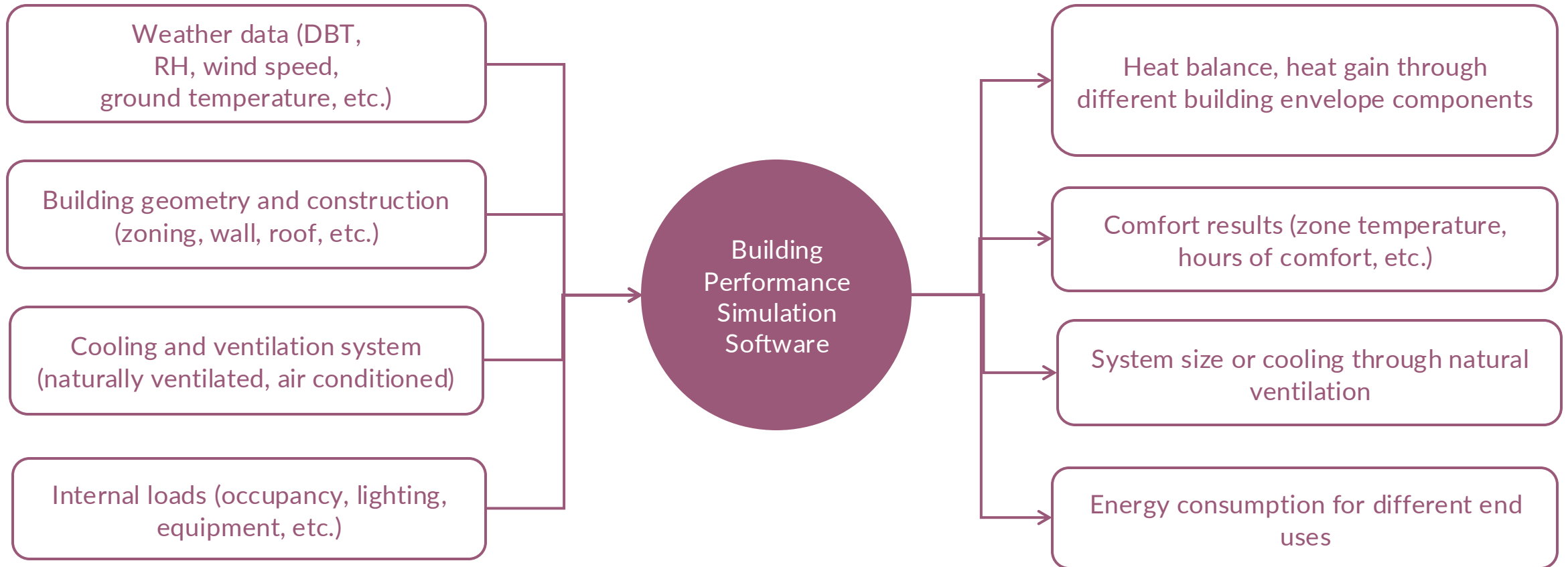

# BUILDING SIMULATION SOFTWARE

## Essential skills required

### User

- Knowledge and understanding of the building physics, HVAC
- Good technical common sense:
  - Ability to relate results to physical understanding, memory of previous situations
  - Ability to analyze results and question them
- Ability to make quick parallel calculations
  - Simple back of the envelope
  - Equation-based models
- Representation of results data for coherent checking
- Ability to identify important parameters upfront
  - Define relevant parametric studies
- Willingness to discuss inputs and results with others
- Needs patience

### Guidelines and Tips

- Weather data:
  - Be careful with synthetic data
  - When using weather data for the first time for a location, plot the data to be sure that they are consistent
- Check for non-library materials, components and systems
- Check for extreme conditions, then conduct an annual run:
  - Identify hottest, most humid and coldest weeks
  - Prepare outputs to compare the results of different runs on these weeks on the same plot (post treatment may be needed)
- Check the hourly results:
  - Check if set-points are met
  - Check if strategies play out as expected e.g., sequence of natural ventilation, evaporative cooling and active cooling
  - Check if movable blinds are operated

# Daylight Simulation

Tools for Visual Comfort

Lux levels (<)

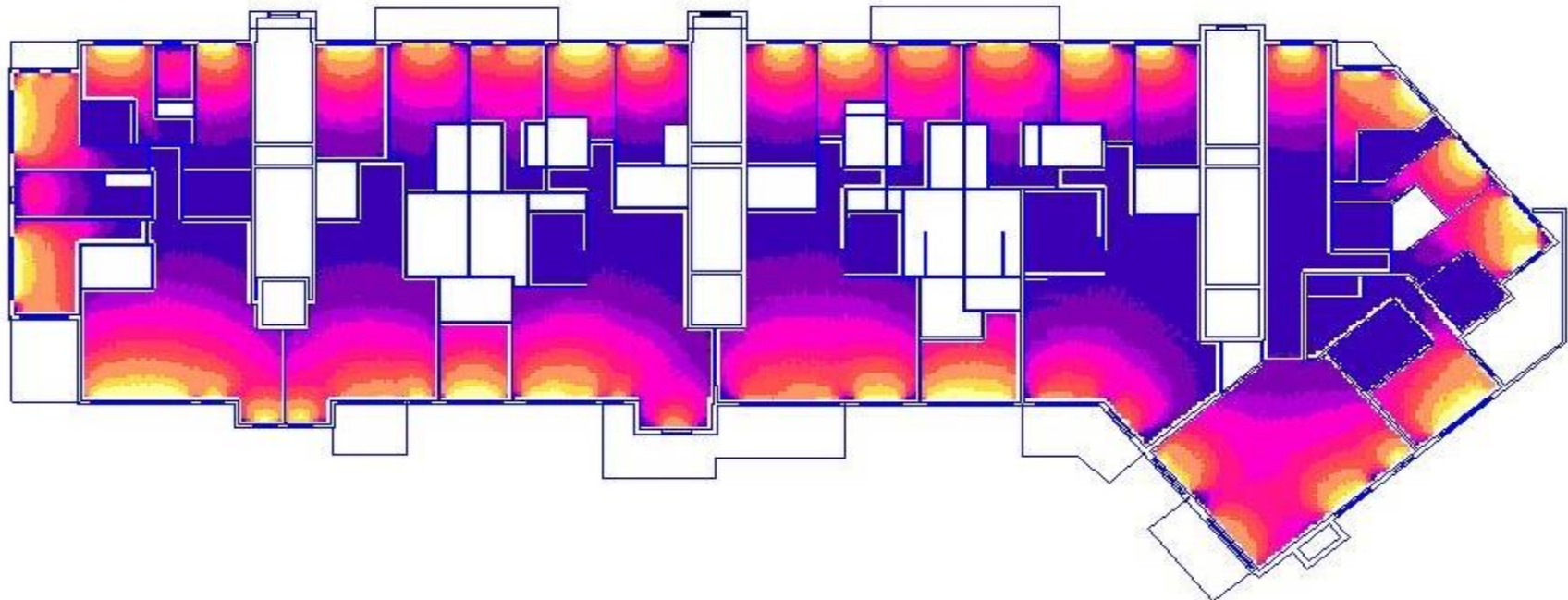
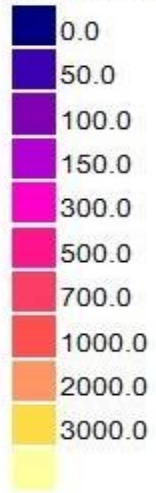

Image source: <https://egreenideas.com/green-ideas-daylight-modeling-services/>

# DAYLIGHT SIMULATION

## Understanding objectives

- Daylight analysis and simulation are processes that help determine the **amount and quality of natural light** in a building, and how it **affects the occupants and energy consumption**
- It involves simulating light behavior, using **physical models or digital tools to predict light distribution**, intensity and impact on interior spaces
- Helps to understand how **building form interacts with light availability** at different times of day and seasons. It can help reduce the need for artificial lights, which can lower energy costs and emissions
- These processes are often used in the **early stages of the design process** to optimize designs and meet sustainability goals

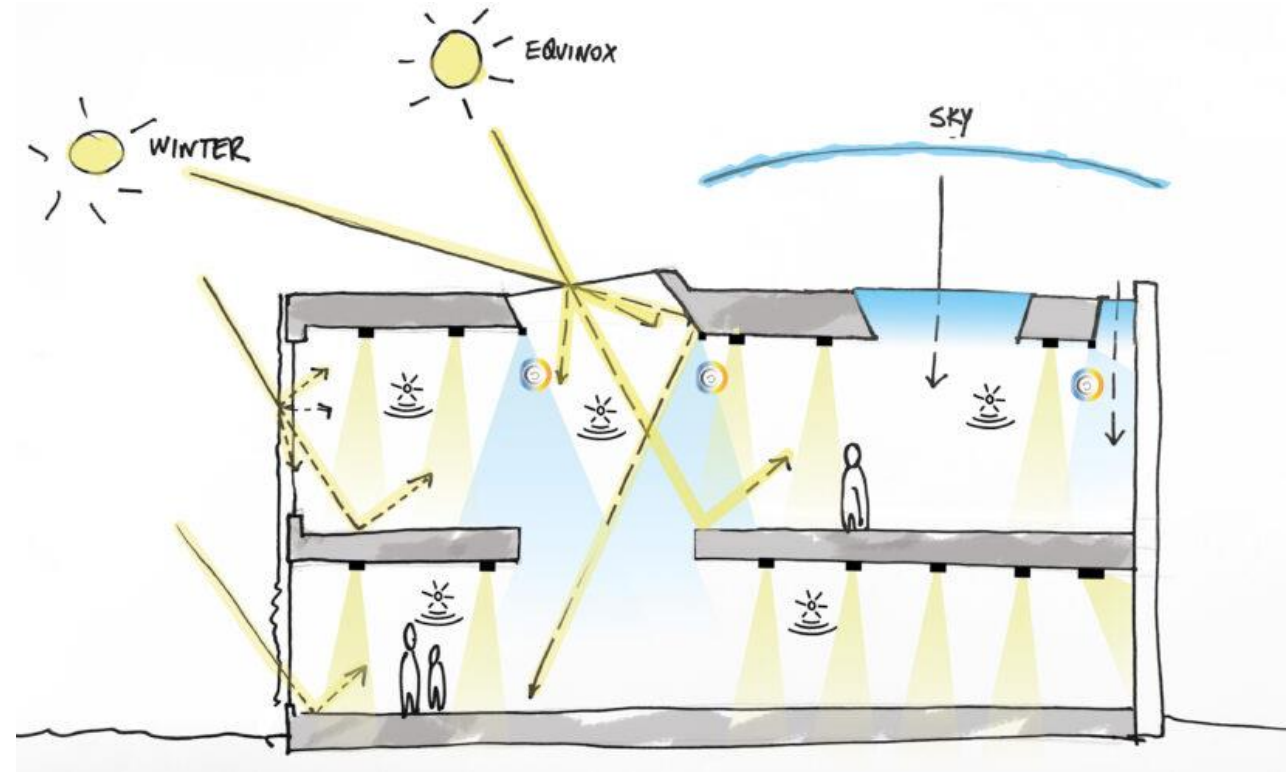

Image source: <https://whitearkitekter.com/news/daylight-simulation-tools-and-their-integration-in-the-design-workflow/>

# DAYLIGHT ANALYSIS

## Inputs required

### Input parameters for simulation:

- Building geometry
- Surface material properties (color, texture, reflectance)
- Light source (location, sky model)
- Sensors grid location and size

### Software used in the simulation:

- Radiance
- LightStanza
- Ladybug Tools (Honeybee)
- Daysim
- Open Studio
- VELUX Daylight Visualizer
- IESve, etc.

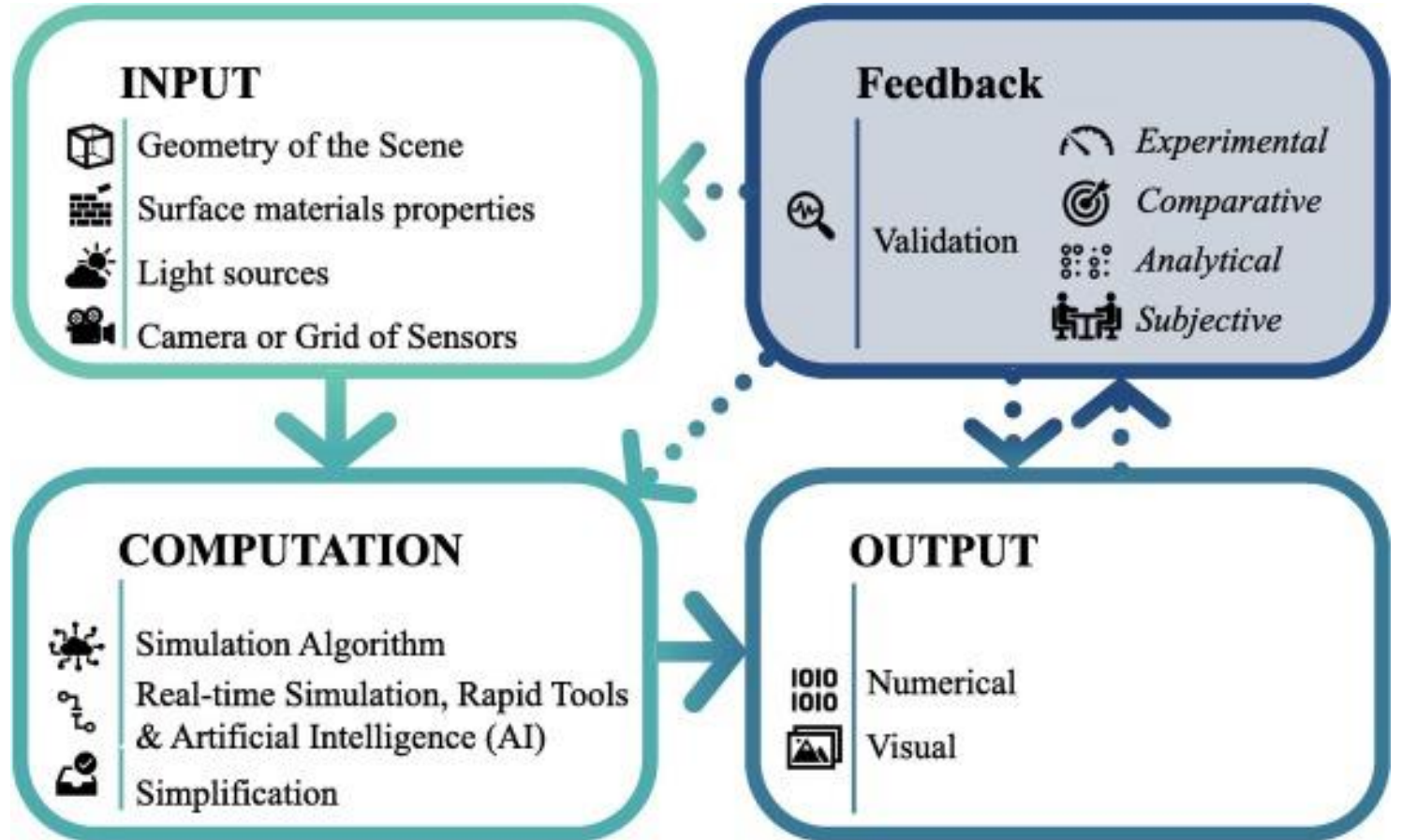

# DAYLIGHT ANALYSIS

## Metrics

### Illuminance (Lux)

The amount of light that falls on a surface per unit area. Daylight illuminance levels <100 lux are generally insufficient for most tasks

### Daylight Factor (DF)

The ratio of indoor illuminance to available outdoor illuminance under overcast sky conditions indicates daylight availability

### Daylight Autonomy (DA)

The percentage of time that a building or space's daylight levels are above a specified illuminance level

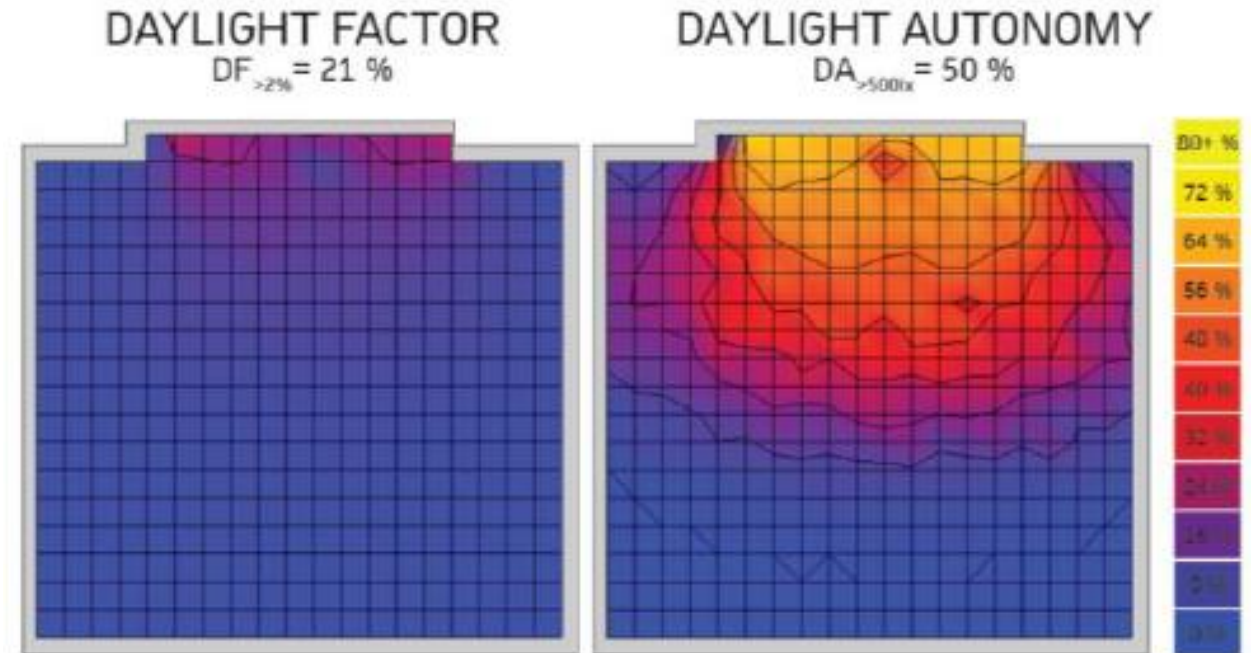

# DAYLIGHT ANALYSIS

## Metrics

### Annual Sunlight Exposure (ASE)

Measures areas that receive excessive direct sunlight over a year, useful for glare and overheating analysis

### Spatial Daylight Autonomy (sDA)

The percentage of an area that receives sufficient daylight (usually 300 lux) for a specific period, measuring daylight sufficiency

### Useful Daylight Illuminance (UDI)

The percentage of annual occupied hours that falls within predefined lower and higher illuminance limits (100 to 3000 lux)

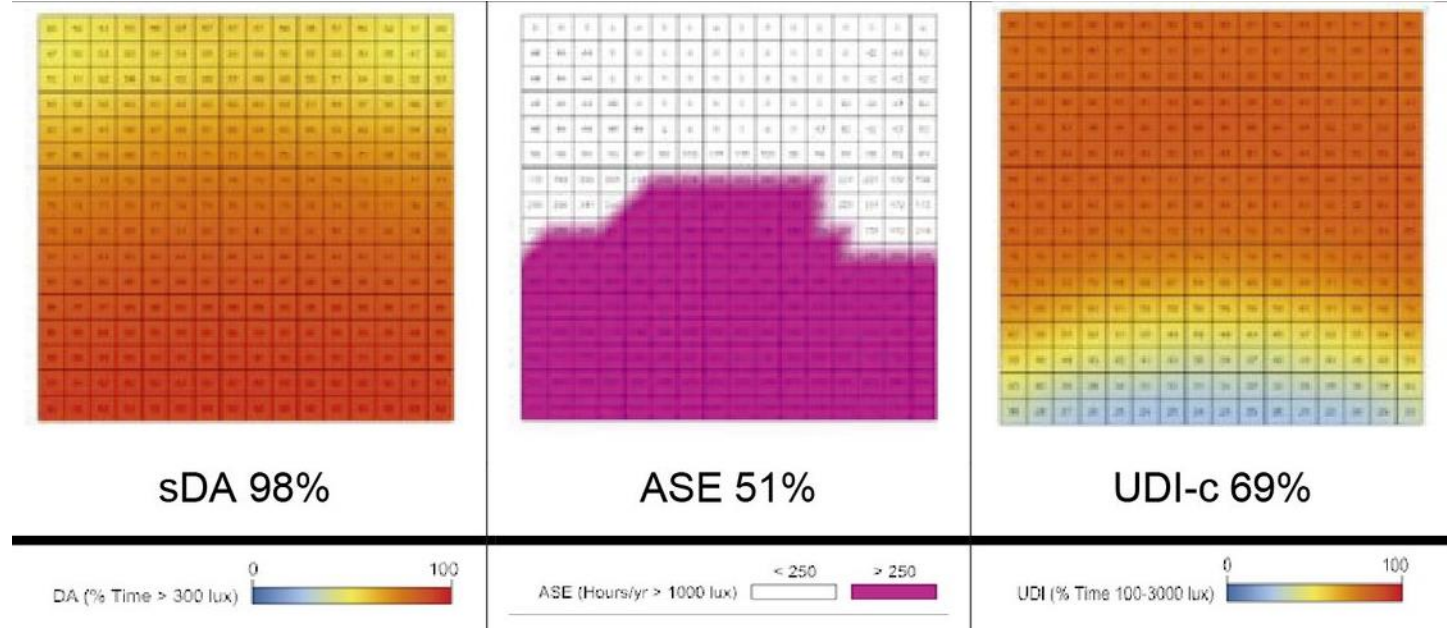

Image source: <https://solarlits.com/jd/7-107>

# DAYLIGHT ANALYSIS

## Metrics

### Glare Metrics (DGP)

- Daylight glare probability (DGP) is a metric that predicts the likelihood of an observer experiencing discomfort glare at a given orientation and view position
- DGP is typically calculated using a fisheye rendering with an opening angle of 180 degrees. The values for DGP range from 0% to 100% and are divided into four bands:

DGP	
< 0.34	Imperceptible
0.34 – 0.38	Perceptible
0.38 – 0.45	Disturbing
> 0.45	Intolerable

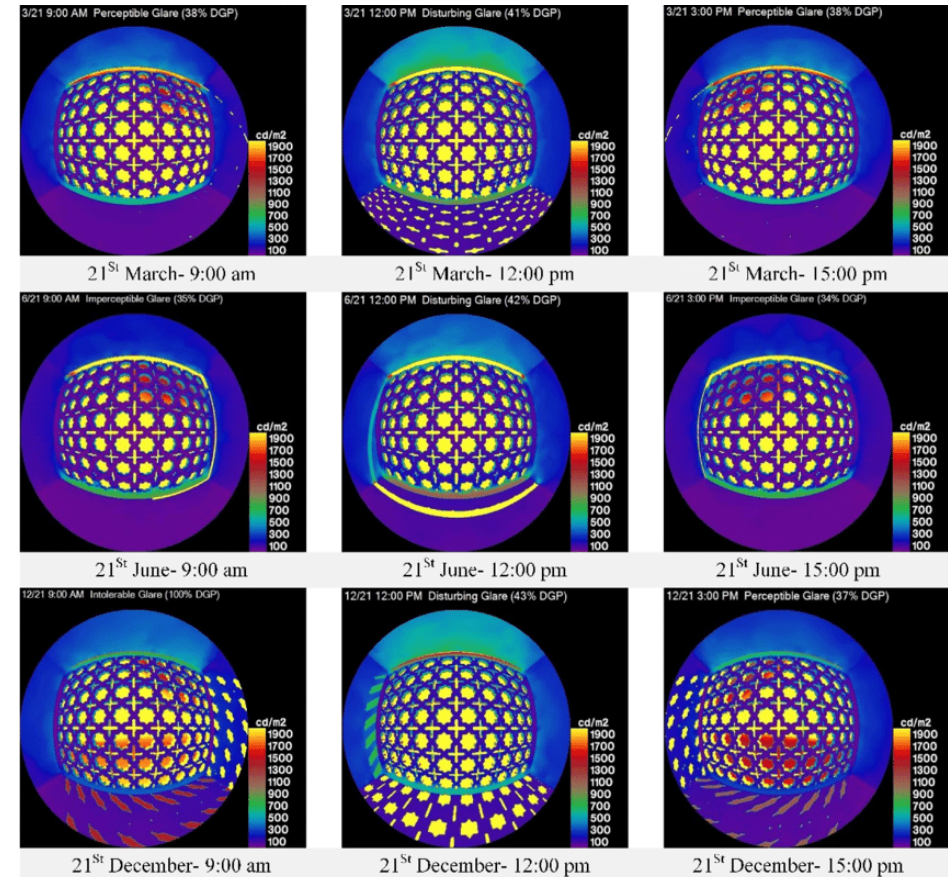

Image source: [https://www.researchgate.net/figure/Daylight-Glare-Probability-DGP-in-three-different-days-of-8-Point-Star-for-south-facade\\_fig8\\_345505966](https://www.researchgate.net/figure/Daylight-Glare-Probability-DGP-in-three-different-days-of-8-Point-Star-for-south-facade_fig8_345505966)

# CFD Simulation

Tools for Ventilation Potential

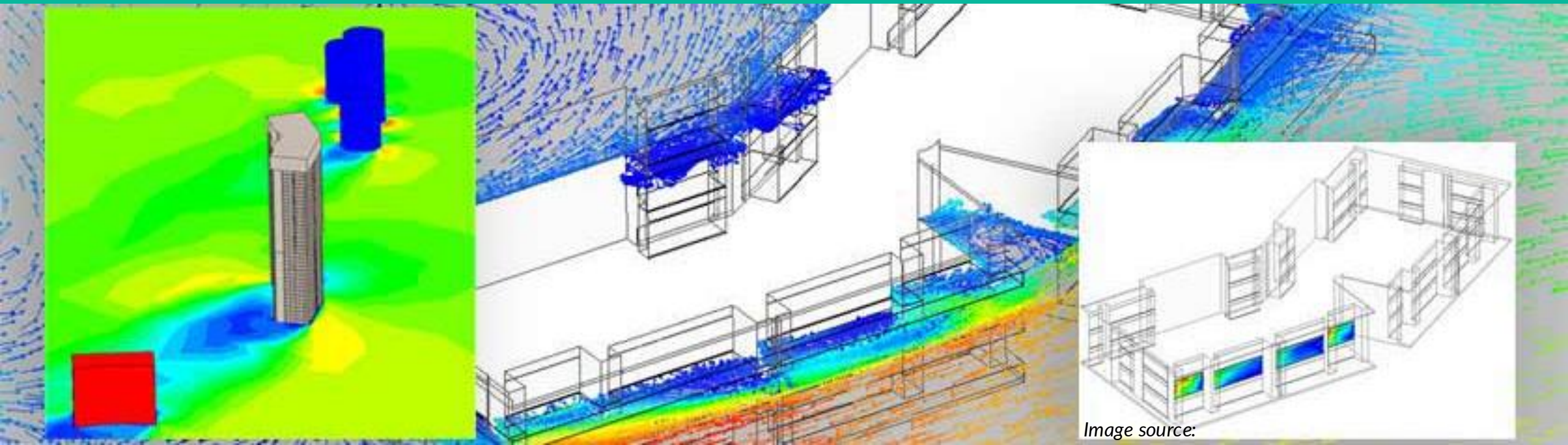
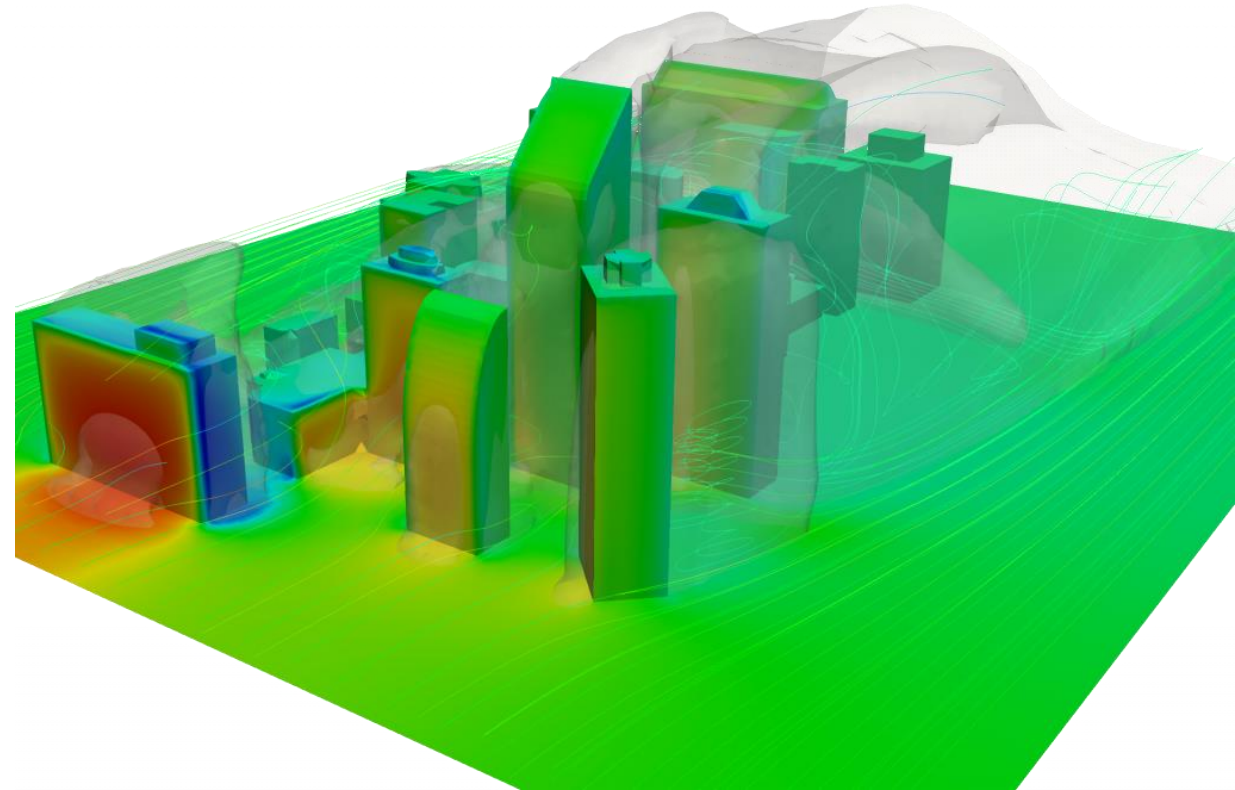

Image source:

# CFD SIMULATION

## Utility of computational fluid dynamics (CFD)

- CFD is used to **visualize and quantify** velocity and pressure profiles in and around buildings
- The effect of both **mechanical and wind-driven** natural ventilation can be accessed
- It is seen as an **early design** decision tool
- Useful for architects, engineers, town/city planners and consultants



Quick decision-making to optimize building design with better **wind-driven ventilation**

Image source: <https://www.idealsimulations.com/applications/architecture/>

# CFD SIMULATION SOFTWARE

## Software packages and considerations for simulation

### List of software packages

- **Energy Plus** (graphical user interface e.g., Design Builder, Sefaira, Simergy)
- TRNSYS
- Vayu Pravah (an OpenFOAM software)
- MicroFlo-CFD
- SimFlow
- Ansys Fluids

### Simulation and other considerations

- Simulate at neighborhood level
  - Identify the target and surrounding buildings for the analysis (cover up to 3H radius)
- Simulate at building
  - Refer to Google Earth for site details
- Consider ground slope of each block
- Set surrounding environment
- The predominant wind direction with magnitude
- The reference wind height of magnitude
- Optional custom wind profile

Source: <https://www.ibpsa.us/best-directory-list/>

[https://climate.onebuilding.org/papers/2005\\_07\\_Crawley\\_Hand\\_Kummert\\_Griffith\\_contrasting\\_the\\_capabilities\\_of\\_building\\_energy\\_performance\\_simulation\\_programs\\_v1.0.pdf](https://climate.onebuilding.org/papers/2005_07_Crawley_Hand_Kummert_Griffith_contrasting_the_capabilities_of_building_energy_performance_simulation_programs_v1.0.pdf)

# CFD SIMULATION SOFTWARE

## Inputs and outputs

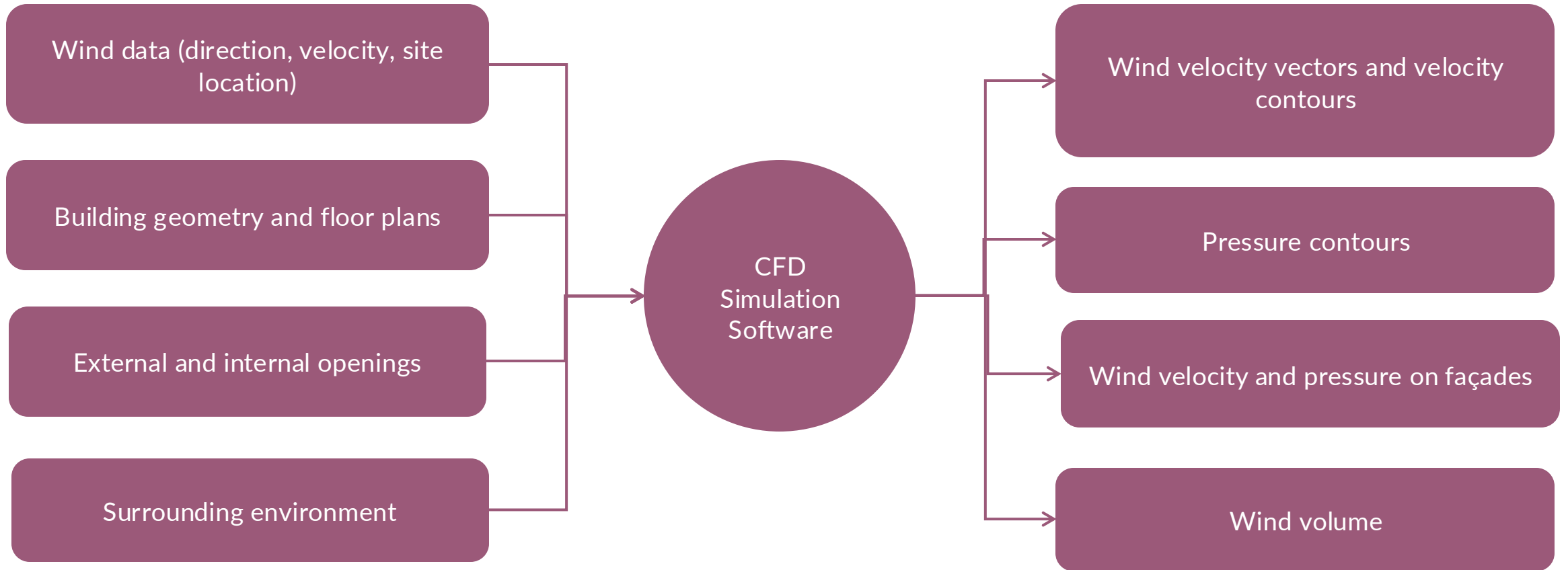

# CFD SIMULATION SOFTWARE

## Using the results

- Identification of **strong and weak spots** for utilizing natural ventilation potential
- **Variation** of wind potential from bottom ground floor to top floor
- Data representation using various techniques for better explanation of results
- Identification of **strong spots** for assisted mechanical ventilation
- Ideas for **design alteration** to improve wind-driven ventilation

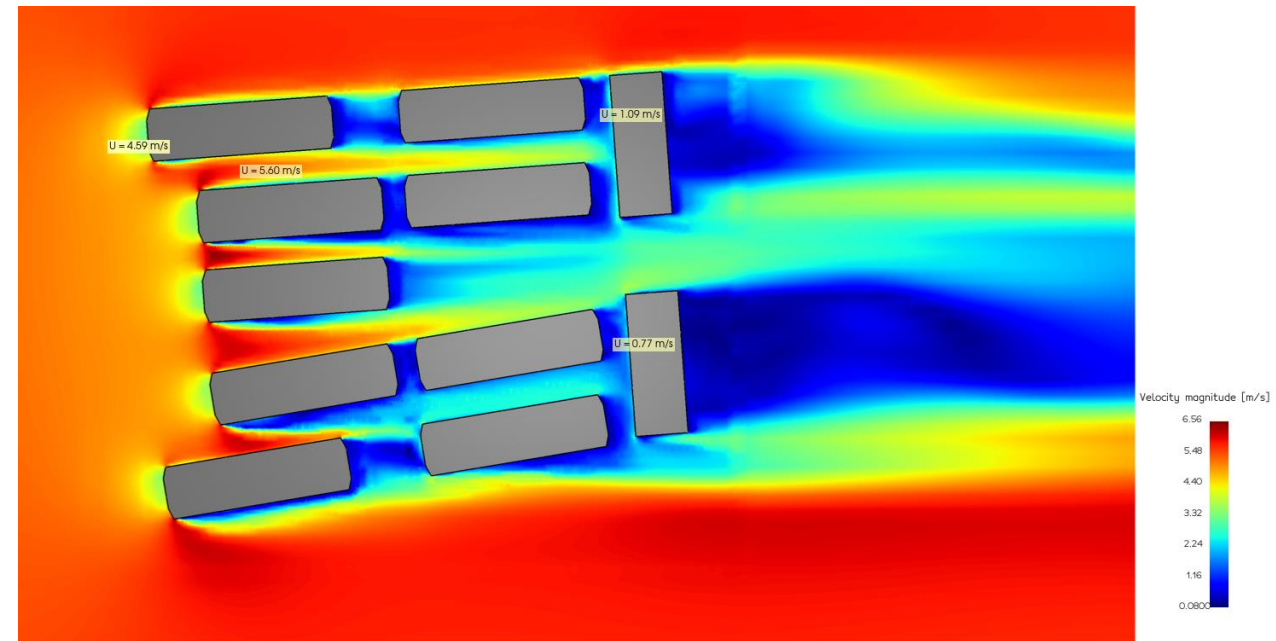

Representation of wind movement around multiple buildings

# Case Example

Aranya Bhawan, Jaipur, India



# ARANYA BHAWAN

## Case example: Government office building

- **Client:** Rajasthan Forest Department
- **Executing Agency:** Rajasthan State Road Development and Construction Corporation Ltd. (RSRDC)
- **Architects:** Mathur, Ugam and Associates
- **Built-up area:** ~10,000m<sup>2</sup> (excluding basement parking and service area)
- **Number of floors:** 5 (Ground + 4 floors) + one basement level for parking and services
- **Number of users:** ~350
- **Types of spaces:** Offices, auditorium, guest rooms, museum and library

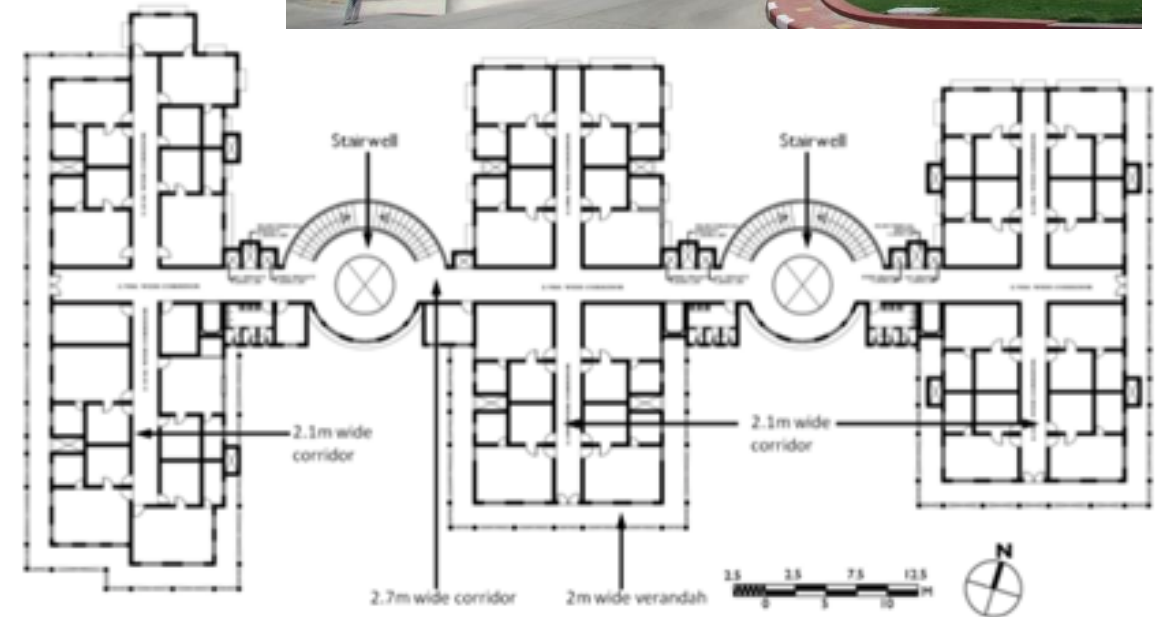

# ARANYA BHAWAN

## Project timeline

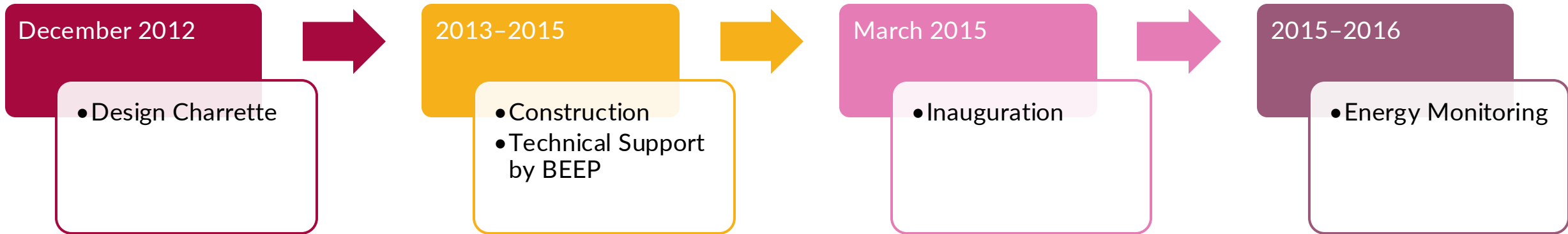

# ARANYA BHAWAN

## Original building design

### Approved architectural drawings

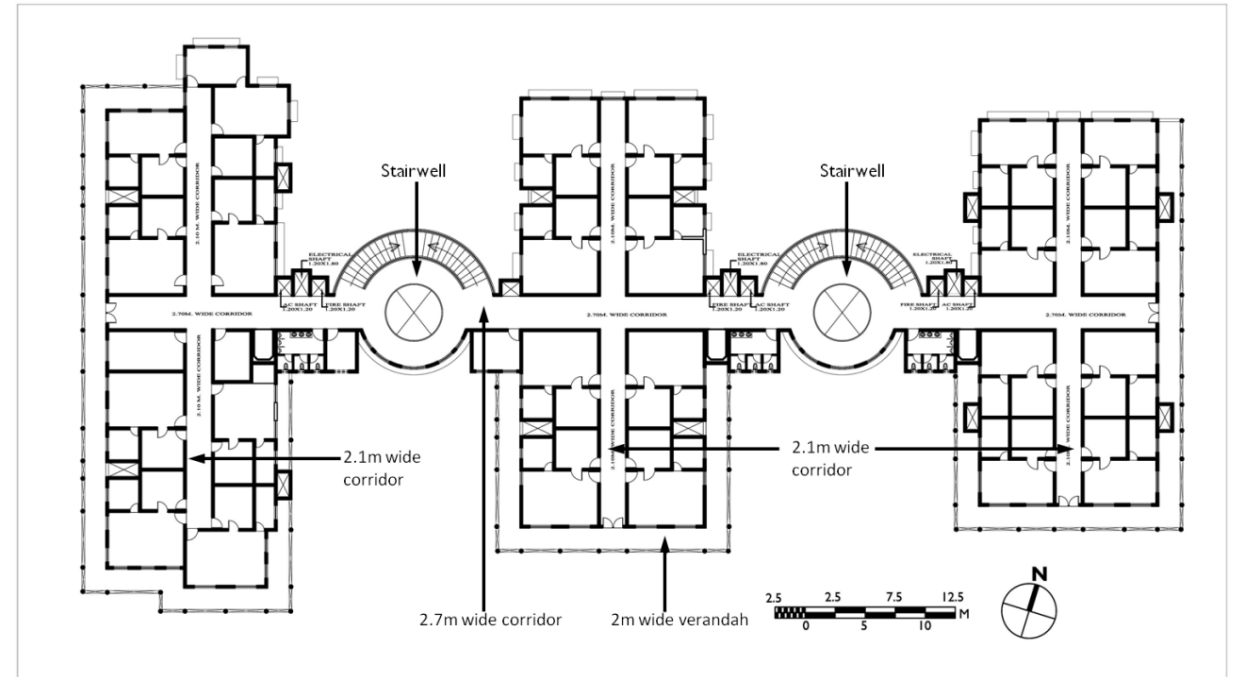
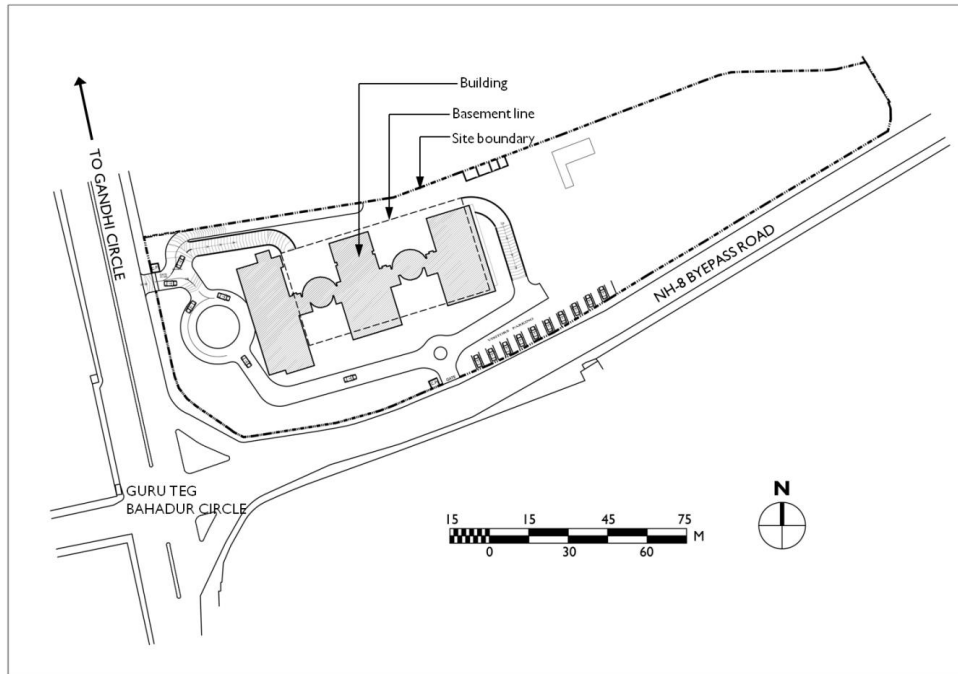

# ARANYA BHAWAN

## Original building design

### Key specifications

#### Building envelope:

- Walls: 230mm brick wall (U-value: 2.05 W/m<sup>2</sup>.K)
- Roof: 150mm RCC slab (U-value: 3.2 W/m<sup>2</sup>.K)
- Glazing: Single glazing 5mm clear glass (U-value: 5.8 W/m<sup>2</sup>.K ; SHGC: 0.8 ; VLT: 85%)
- Veranda on each floor for shading of walls and windows

LPD: ~7 W/m<sup>2</sup>

EPD: ~10 W/m<sup>2</sup>

#### HVAC system:

- Air cooled VRV system (COP: 2.75)
- Cooling system size: 230 TR (~320 ft<sup>2</sup>/TR)

**Budget: INR 300 million (~INR3,000/ft<sup>2</sup>, including services)**

### Charrette goals

- Budget: Should not deviate much from the approved budget
- ECBC compliance
- Target EPI: <90 kWh/m<sup>2</sup>.year (5-star rating as per BEE star rating for air-conditioned office buildings)

**Energy Star Rating Program**  
(more than 50% air-conditioned built-up area)  
Climatic Zone: Composite

EPI(Kwh/sqm/year)	Star Label
190-165	1 Star
165-140	2 Star
140-115	3 Star
115-90	4 Star
Below 90	5 Star

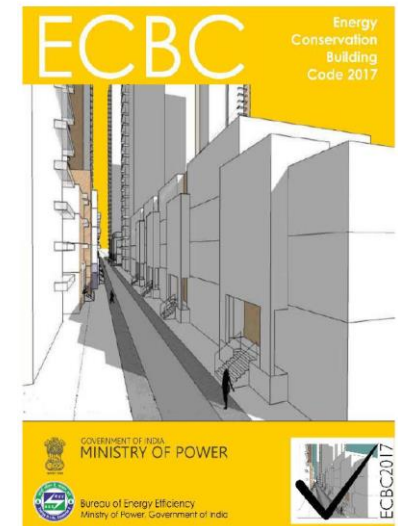

# ARANYA BHAWAN

Area simulated under charrette

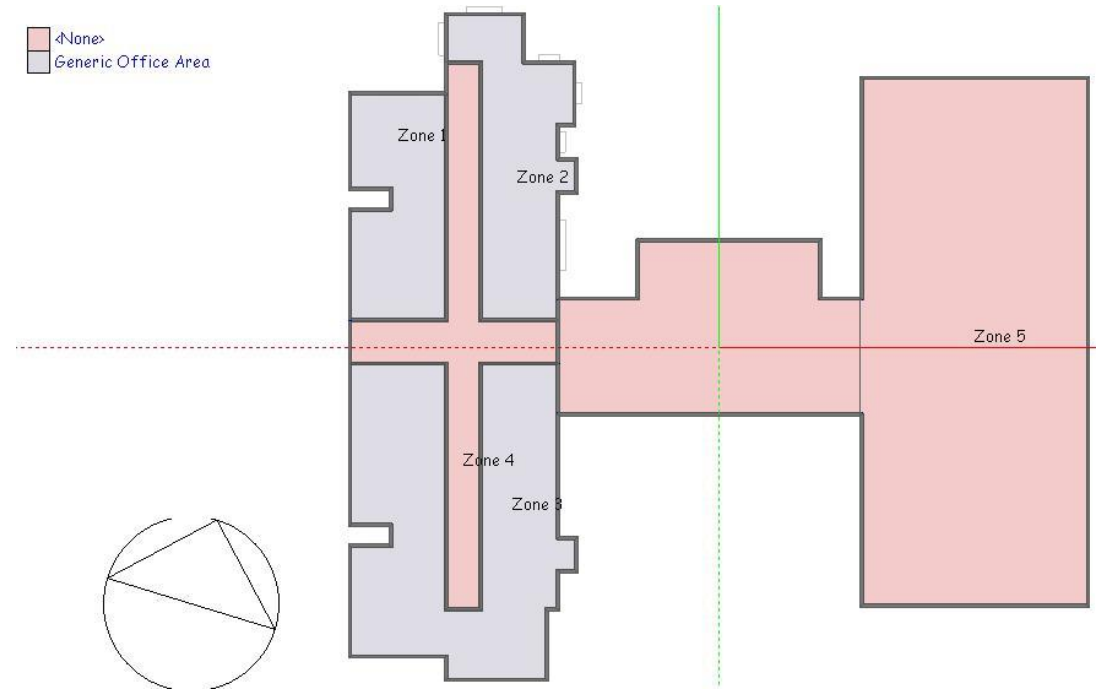
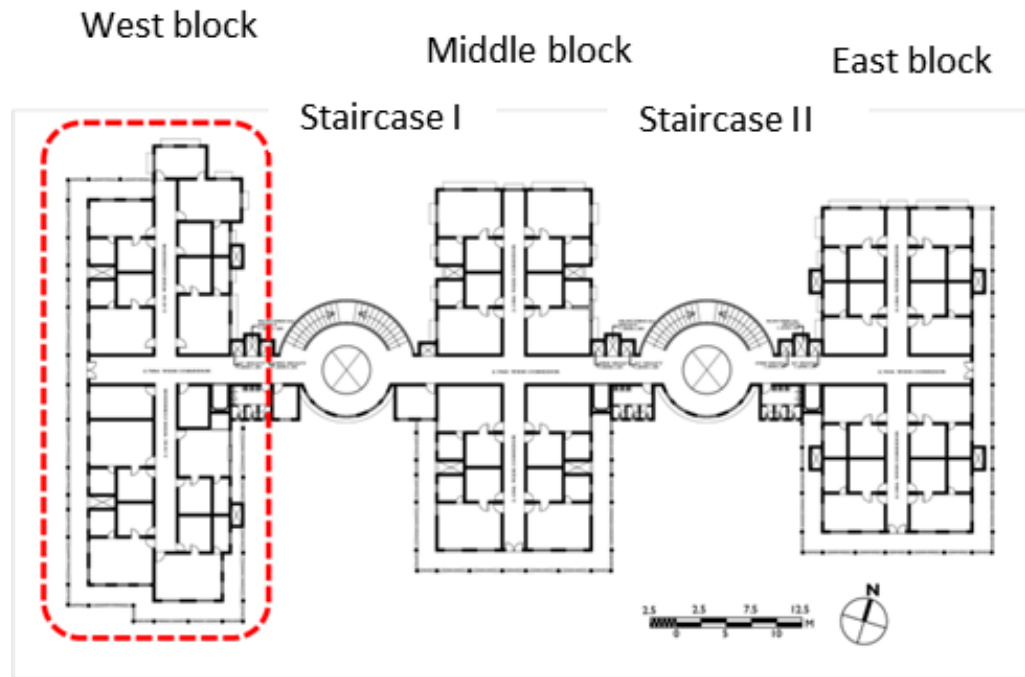

Occupancy: 25 people in one typical floor of the western block (09:30 am to 05:30 pm)

# ARANYA BHAWAN

Original design: Energy demand break-up

- Reduce cooling load
  - Reduce heat ingress
- Provide cooling efficiently

Cooling 67%

Equipment 29%

Lighting 4%

\*Artificial lighting remains OFF, if daylight is sufficient

EPI: 77 kWh/m<sup>2</sup>.year

# ARANYA BHAWAN

Proposed design: With passive measures

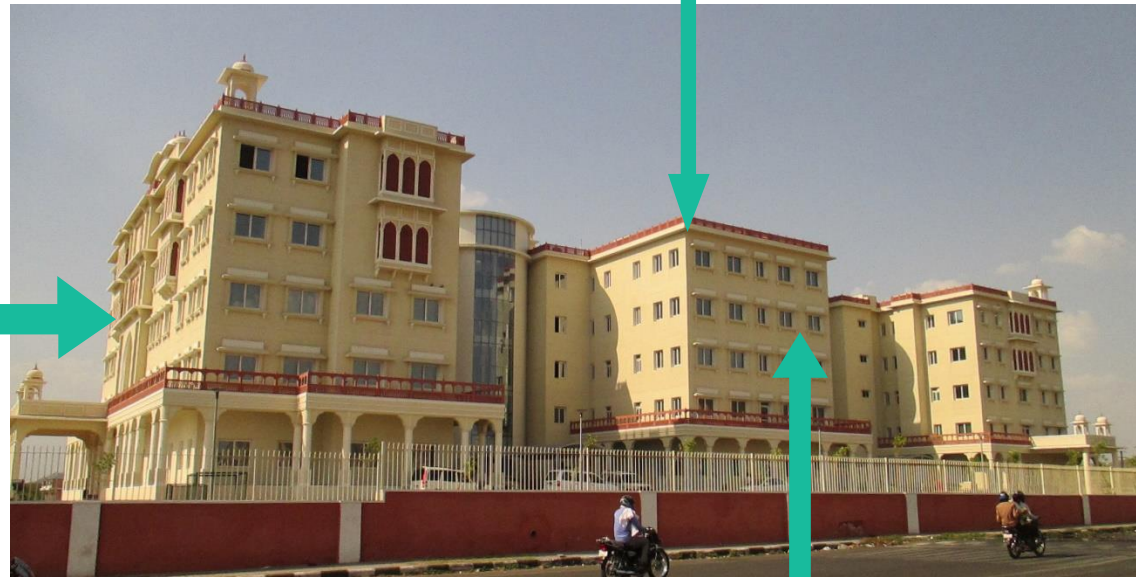

Roof U-value:  $0.6 \text{ W/m}^2\cdot\text{K}$

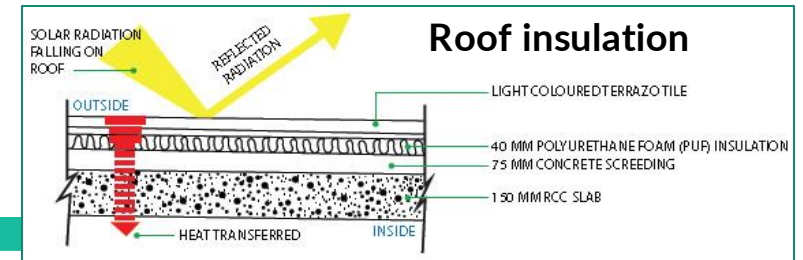

Reduction in glazed area  
(WWR: ~20%)

Double-glazed windows

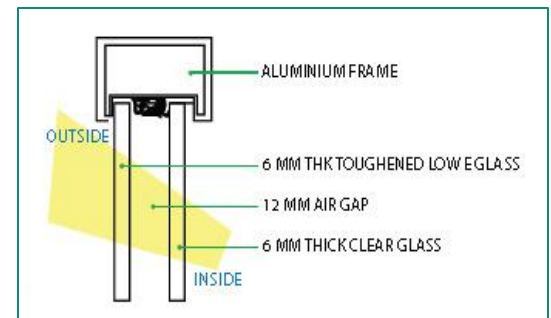

Window U-value:  $1.8 \text{ W/m}^2\cdot\text{K}$   
SHGC: 0.24  
VLT: 36%

Wall U-value:  $0.5 \text{ W/m}^2\cdot\text{K}$

Wall insulation

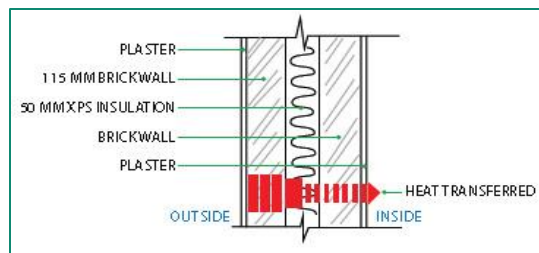

# ARANYA BHAWAN

## Proposed design: Active measures and renewable energy

### Energy efficient lighting

- LEDs and T5
- Lighting power density (LPD) of  $\sim 6 \text{ W/m}^2$

### Energy efficient cooling system

- Centralized high efficiency water-cooled chiller (COP: 5.8)
- Sewage treatment plant (capacity:  $15 \text{ m}^3/\text{d}$ ) to provide water for cooling towers

### Solar photovoltaic (SPV) system

- Rooftop 45 kWp grid-connected SPV system with net-metering

### Solar photovoltaic: Thumb rules

- **Area required:**  $\sim 10 \text{ m}^2/\text{kWp}$
- Only shadow-free area should be considered for solar photovoltaic system
- **Energy generation:** 1,400–1,600 kWh/kW per year
- **Cost:** INR40,000 per kWp (without batteries)

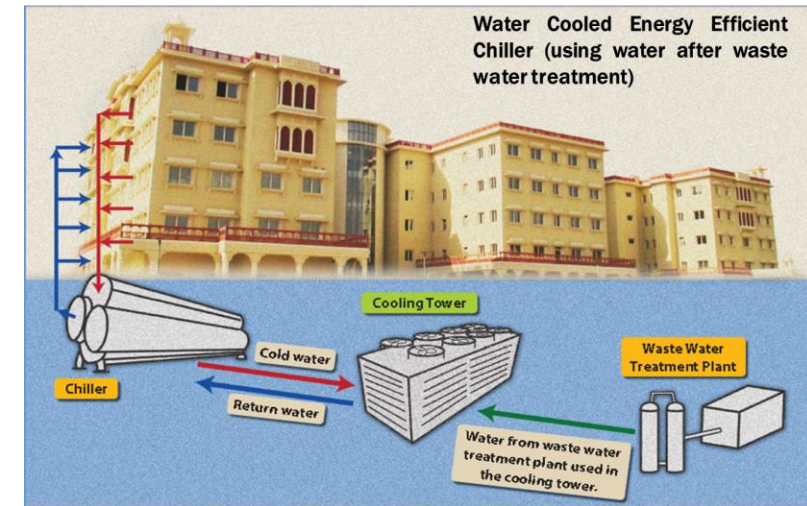

# ARANYA BHAWAN

Calculated savings through simulation

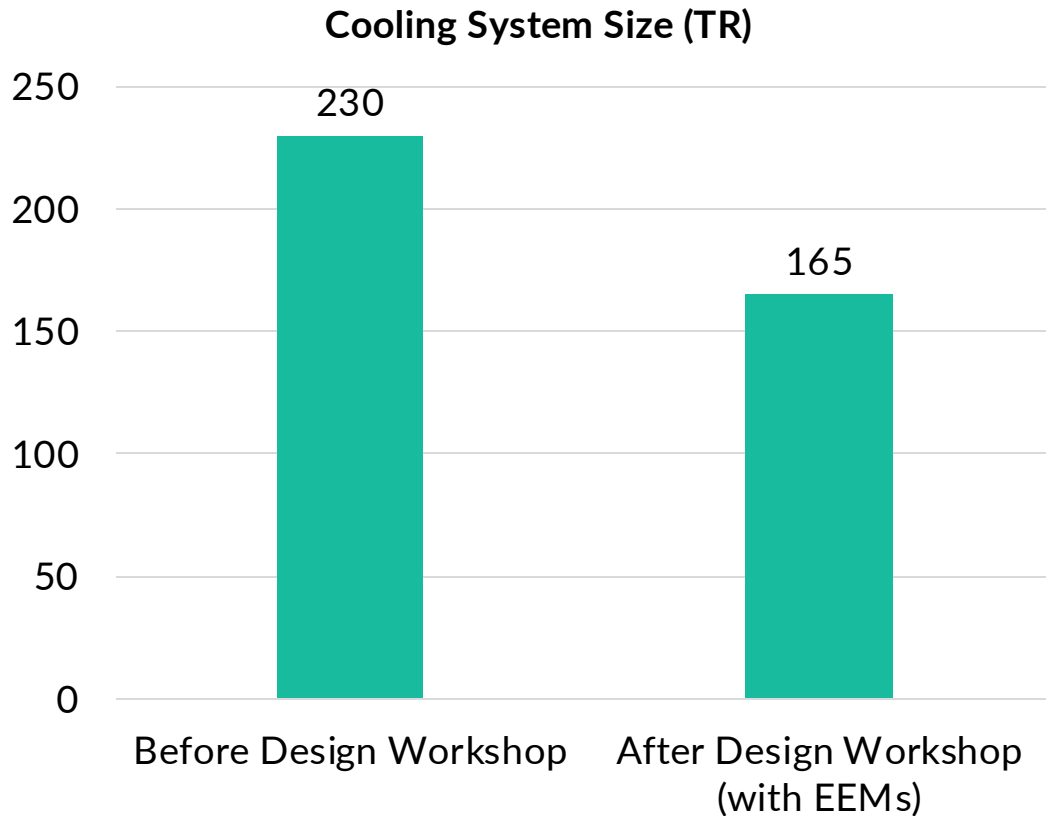

**28% reduction**

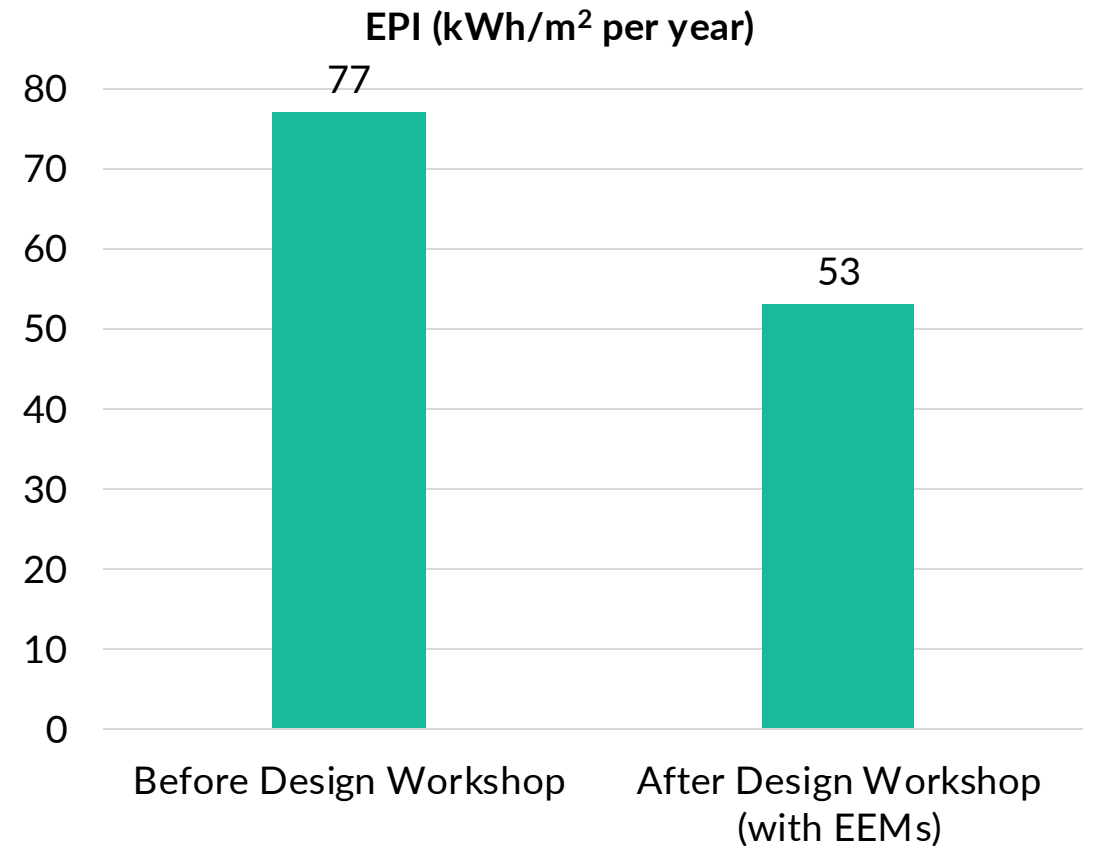

*\*(Solar Photovoltaic contribution not included)*

**31% reduction**

# ARANYA BHAWAN

## Cost estimates and payback calculation

- Increase in budget: ~INR 6 million
- Approved budget: INR 300 million
- Increase in budget: 2% (acceptable 😊)
- Typical cost for envelope measures:
  - Cost of adding 50mm EPS in brick cavity wall: ~INR700/m<sup>2</sup>
  - Cost of adding 50mm PUF insulation on roof slab: ~INR900/m<sup>2</sup>
  - Additional cost of high performance (low SHGC) glazing as compared to single clear glazing: ~INR3,000/m<sup>2</sup>
- Savings from operational energy: ~INR2.0 million/year
- Payback period: ~3 years

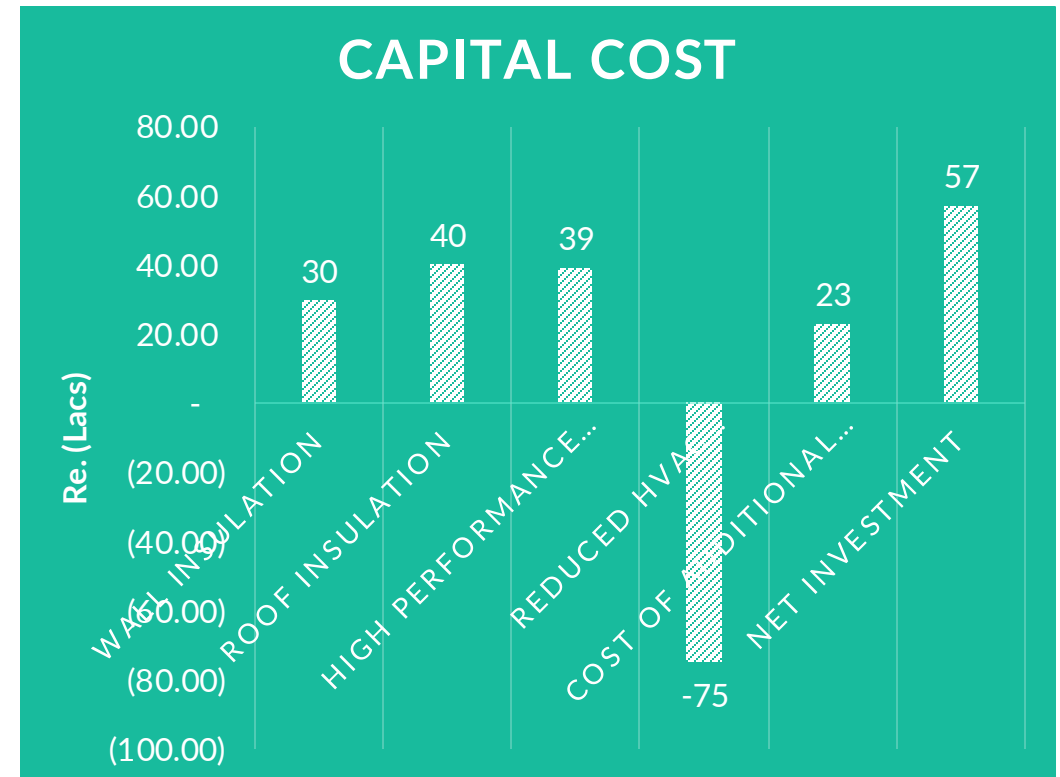

Note: Additional equipment includes cost of STP and additional cost for improved lighting system

# Thank you!

For more information, visit us at <https://ALCBT.GGGI.ORG>  
or scan the QR code below



## IKI Independent Complaint Mechanism

Any person who believes they may be harmed by an IKI project or who wish to report corruption or the misuse of funds, can lodge a complaint to the IKI Independent Complaint Mechanism at [IKI-complaints@z-u-g.org](mailto:IKI-complaints@z-u-g.org). The IKI complaint mechanism has a panel of independent experts who will investigate the complaint. In the course of the investigation, we will consult with the complainant so as to avoid unnecessary risks for the complainant. More information can be found at <https://www.international-climate-initiative.com/en/about-iki/values-responsibility/independent-complaint-mechanism/>.

 [www.gggi.org](http://www.gggi.org)

 [@gggi\\_hq](https://twitter.com/gggi_hq)

 [@GGGIHQ](https://www.instagram.com/gggi_hq)

 [@GGGIHQ](https://www.facebook.com/gggi_hq)

 [@gggi\\_hq](https://www.linkedin.com/company/gggi_hq)

 [@GGGIMedia](https://www.youtube.com/channel/UCGgI-Media)



Supported by:



on the basis of a decision  
by the German Bundestag